

CITY OF SANTA ROSA REGIONAL WATER REUSE ENERGY OPTIMIZATION PLAN

JULY 2019

City of Santa Rosa Water Department
In Conjunction with Kennedy/Jenks Consultants



*City of Santa Rosa
Regional Water Reuse
Energy Optimization Plan*

PREPARED BY



IN CONJUNCTION WITH

Kennedy/Jenks Consultants

July 2019

TABLE OF CONTENTS

Executive Summary	ES-1
Technical Memorandum #1: Laguna Wastewater Treatment Plant Process Energy Audit	1-1
1.1 Recommendations	1-1
1.2 Background.....	1-4
1.3 Overview of Audit Methodology.....	1-8
1.4 Detailed Descriptions of Recommended Energy Efficiency Measures.....	1-13
1.5 Detailed Descriptions of Process Improvements	1-25
Technical Memorandum #2: Compost Facility Energy Audit	2-1
2.1 Recommendations	2-1
2.2 Background	2-2
2.3 Overview of Audit Methodology.....	2-4
2.4 Detailed Descriptions of Recommended Energy Efficiency Measures.....	2-5
2.5 Detailed Descriptions of Energy Efficiency Measures Not Recommended.....	2-10
Technical Memorandum #3: Recycled Water System Energy Audit	3-1
3.1 Recommendation	3-1
3.2 Background	3-2
3.3 Overview of Audit Methodology.....	3-5
3.4 Detailed Descriptions of Recommended Energy Efficiency Measures.....	3-11
3.5 Detailed Descriptions of Energy Efficiency Measures Not Recommended.....	3-15
Attachment A: Recycled Water Storage Pond Layout.....	3-16
Attachment B: Recycled Water Uses Allowed in California	3-16
Attachment C: Recycled Water Pump Station Improvements as of April 2014	3-17
Attachment D: Background Recycled Water Pump Station Information	3-20
Attachment E: Recycled Water Pumps Excluded from Analysis.....	3-22
Technical Memorandum #3a (Amendment): Reclamation System Energy Audit	3a-1
3a. 1 Recommendation.....	3a-1
2 Background.....	3a-2
3 Detailed Descriptions of Energy Efficiency Measures Not Recommended.....	3a-5
Technical Memorandum #4: Geysers Energy Audit	4-1
4.1 Recommendation	4-1
4.2 Background	4-2
4.3 Overview of Audit Methodology.....	4-4
4.4 Detailed Descriptions of Recommended Energy Efficiency Measures.....	4-7
4.5 Detailed Descriptions of Energy Efficiency Measures Not Recommended.....	4-8

Technical Memorandum #5: Brainstorming Workshop #1 Process and Outcomes	5-1
5.1 Background	5-1
5.2 Workshop Objective.....	5-2
5.3 Participants	5-2
5.4 Workshop Process Overview	5-2
5.5 Project Scoring and Outcomes	5-3
5.6 Scope of Work for Short-Listed Projects	5-5
Technical Memorandum #6: Laguna Treatment Plant Waste Heat Investigation	6-1
6.1 Recommendations Summary	6-1
6.2 Existing System Summary	6-2
6.3 Waste Heat Recovery Options.....	6-5
6.4 Recommended Energy Efficiency Measure.....	6-5
6.5 Energy Efficiency Measures Recommended for Further Investigation	6-9
6.6 Not Recommended Energy Efficiency Measures	6-10
Technical Memorandum #7: Energy Management Software Investigation	7-1
7.1 Recommendation Summary	7-1
7.2 Existing System Summary	7-2
7.3 Subregional SCADA Abilities	7-5
7.4 Recommended Energy Efficiency Measure.....	7-6
7.5 Recommended Process Improvement	7-11
7.6 Process Improvements Recommended for Further Investigation.....	7-13
Technical Memorandum #8: Irrigation System Optimization Investigation	8-1
8.1 Goal of this Irrigation System Optimization Investigation	8-1
8.2 Recommendation Summary	8-1
8.3 Background and Methodology.....	8-2
8.4 Recommended Energy Efficiency Measures	8-3
8.5 Energy Efficiency Measures Recommended for Further Investigation	8-5
8.6 Not Recommended Energy Efficiency Measures	8-9
Technical Memorandum #9: Comprehensive Solar PV Investigation	9-1
9.1 Goal of this Solar PV Investigation	9-1
9.2 Recommendation Summary	9-2
9.3 Declining Cost of Solar PV	9-2
9.4 Site Evaluation.....	9-3
9.5 Siting Criteria and Constraints	9-7
9.6 Site Scoring Metrics	9-8
9.7 Siting Evaluation Matrix	9-8
9.8 Site Weighting and Ranking.....	9-10

Regional Water Reuse Energy Optimization Plan

9.9	Preferred Site Recommendations	9-11
9.10	Solar PV Installation Options.....	9-11
9.11	Ownership Structures	9-11
9.12	Sonoma Clean Power Impacts on Solar Projects.....	9-13
9.13	Incentives	9-14
9.14	Cost-Effective Analysis	9-15
9.15	Comparison of Costs and Savings.....	9-21
9.16	Recommendation	9-22
9.17	Next Steps	9-23
	Appendix TM#9	A9-1
	A – Energy Production from Different Types of Solar Systems.....	A9-2
	B – Solar PV Installation Options	A9-4
	C – Local Solar PV Companies and Considerations Making a Selection.....	A9-7
	D – Purchase Structures and Roles	A9-9
	E – Potential Solar PV Incentive Programs	A9-13
	F – Evaluation of Existing City Solar PV Systems	A9-18
	G – Maps of the Top 5 Individual Potential Solar PV Sites.....	A9-20
Technical Memorandum #10: Mechanical Digester Mixing Investigation		10-1
10.1	Recommendation Summary	10-1
10.2	Background and Current Conditions.....	10-2
10.3	Digester Mixing Energy Requirements	10-3
10.4	Considerations for Mixing High-Strength Feedstocks	10-5
10.5	Review of 2005 Digester Mixing System Design.....	10-6
10.6	Energy Savings Analysis.....	10-7
10.7	Biosolids Disposal.....	10-9
10.8	Cost/Savings Model Results and Recommendation.....	10-10

EXECUTIVE SUMMARY

The Regional Water Reuse Energy Optimization Plan (EOP) serves as a roadmap for strategically and systematically optimizing energy use in Santa Rosa Water's Regional Water Reuse system. The purpose of the EOP is two-fold: (1) to evaluate current Regional Water Reuse systems and practices and memorialize the many energy efficiency and renewable energy projects completed to-date; and (2) to identify opportunities and a cost-effective project portfolio to move towards energy independence and meeting or exceeding Santa Rosa's greenhouse gas (GHG) reduction target (20% below 2000 levels by 2020). The EOP also supports City Council's Goal, *Promote Environmental Sustainability: Santa Rosa protects and improves the environment through its policies and actions.*

Kennedy/Jenks Consultants (K/J), with assistance from City staff, completed audits of the four Regional Water Reuse systems: Laguna Treatment Plant (LTP), Biosolids/Compost, Reclamation, and Geysers. K/J then completed detailed investigations of projects and processes within these systems that would enhance energy efficiency, reduce energy demand, increase renewable energy generation, and/or improve energy management. These audits and investigations, and the recommendations they provide, are analyzed in ten technical memorandums (TMs):

- TM #1: LTP Audit
- TM #2: Biosolids Compost Facility Audit
- TM #3 and #3a: Reclamation System Audits
- TM #4: Geysers Operations Audit
- TM #5: Brainstorming Workshop
- TM #6: LTP Waste Heat Investigation
- TM #7: Energy Management Software Investigation
- TM #8: Irrigation System Optimization Investigation
- TM #9: Comprehensive Solar Photovoltaic (PV) Investigation
- TM #10: Mechanical Digester Mixing Investigation

The TMs evaluated Energy Efficiency Measures (EEMs), Renewable Energy Measures (REMs), and Process Improvements (PIs). The analyses are meant to give Santa Rosa Water enough information to determine if a measure is feasible, if it would likely result in energy reductions and/or cost savings for the City, and the approximate magnitude of those savings. For measures with direct energy savings, the TMs provide a quantified cost-benefit analysis. For measures with indirect energy savings that are difficult or impossible to quantify (e.g., updating SCADA dashboards to show pump station specific energy), potential energy and cost savings are discussed but not calculated.

SRW staff evaluated and prioritized potential measures for implementation using several metrics. Staff first evaluated the feasibility of measures, given the parameters of the department's water system and how implementation could affect operations. For measures deemed operationally feasible, staff considered the potential costs and energy savings, staff availability, and how easily the measure could be implemented. Measures were ultimately sorted into four broad categories of prioritization:

- **Pursue:** These measures are considered top priority. The City will gather additional research to confirm if and how the measure should be implemented. If a measure is confirmed for implementation it will be evaluated as part of the Capital Improvements Plan, as appropriate. See Table ES-1.
- **Completed or In Planning:** These measures have been implemented by SRW staff, are currently in the process of being implemented, or are already in planning stages for future implementation. See Table ES-2.
- **Not Pursue at this Time:** These measures will not be pursued by SRW at this time for reasons such as operational infeasibility, cost, increased risk of permit violations, or because they were tested and didn't work. This category also includes three measures that are desirable but would be considered at a later date as part of a broader, more holistic investigation or project. See Table ES-3.
- **Not Recommended:** These measures were evaluated by K/J but not recommended for implementation. In most cases, the capital costs outweighed potential cost savings. In other cases, the potential measure did not generate energy savings, was infeasible, and/or was operationally impractical. See Table ES-4.

Tables ES-1 through ES-4 summarize all measures evaluated as part of the EOP, including the rationale for how the measure was prioritized. Each measure is described in detail in its respective TM.

Regional Water Reuse Energy Optimization Plan



Table ES-1. Measures to Pursue

Tech Memo	Title	Description	Prioritization Rationale
#4: Geysers Audit (2014)	EEM 4-1: Restore Pipeline Capacity	Address excessive head losses that are occurring in the Geysers Pipeline within two miles of Bear Canyon Reservoir.	Electricity savings are projected at 109,000 kWh per year, with a net present value of cumulative net savings of \$104,600. Staff will investigate the full scope of the problem and gather updated cost/savings estimates.
#6: LTP Waste Heat Investigation (2017)	EEM 6-4: Lystek Process	Use waste heat to offset energy requirements for the Lystek Process, a low-temperature Thermal Hydrolysis Process for handling of biosolids and organic material.	The City is considering many options for developing Class A products. The Lystek process can be included in future biosolids investigations at minimal cost.
	Uses of Waste Heat	Use waste heat from Cogeneration Unit #3 to heat LTP buildings, for sludge dewatering, or a potential compost drying facility. Have Brown & Caldwell review TM #6 analysis.	Though not quantified in the TM, using waste heat would likely reduce energy costs for LTP operations, and staff values eliminating heat loss. Staff will investigate the feasibility of using waste heat in multiple applications.
#8: Irrigation System Optimization (2017)	EEM 8-12: Upgrade Delta Pump #2	Replace (retrofit) the smaller constant speed motor with a third variable speed drive and reprogram the station PLC to have the ability to automatically alternate online pumps, using the smaller pump for low or no demand periods (similar to Rohnert Park Pump Station).	The Reclamation division is very interested in implementing this measure as it would result in energy and operational savings.
#9: Comprehensive Solar PV Investigation (2017)	REM 9-4: 1 MW Floating Solar Photovoltaic (PV) Installation, PPA	Install 1 MW of floating solar PV panels on Pond B or other reclamation pond using a Power Purchase Agreement. SRW would use the electricity.	This measure could result in significant cost savings for the department. Annual electricity savings and average annual net dollar savings are estimated at 1,358,000 kWh and \$61,800, respectively. The NPV of cumulative net savings is projected at \$881,000. The City will further investigate potential solar installation sizes and configurations, funding options, and cost savings estimates via a Request for Proposals from qualified consultants.
	REM 9-5: Pond Lease for 1 MW Floating Solar Installation	Lease 3-acres of reclamation pond to a solar vendor for a floating solar PV system. The vendor would sell the electricity to SCP and pay us for leasing the site.	Although this project would not result in energy savings for the City, it would generate revenue of approximately \$7,500 per year with minimal up-front costs, and increase the amount of locally-produced renewable energy. The City will consider putting out an RFP from qualified consultants that would investigate leasing pond areas of various sizes, to refine potential revenues for the City.

Regional Water Reuse Energy Optimization Plan



Table ES-2. Measures Complete or In Planning Stage

Tech Memo	Title	Description	Prioritization Rationale
#1: LTP Audit (2014)	EEM 1-2: Replace Ultraviolet (UV) Disinfection	Switching to hypochlorite could result in significant savings from reduced electrical usage (equivalent to 920 HP/day).	Replacement of the UV disinfection system is actively in planning stages. The project will update the system and result in significant energy savings.
	EEM 1-6: Run Idle Cummins Engines on Natural Gas to Generate Electricity	Utilize natural gas to run other generators and reduce purchase of electricity off the grid.	This measure is being implemented as part of the Microgrid project.
	EEM 1-10: Implement Building and Lighting EEMs	BASE energy equipment audit indicated energy savings opportunities in the building envelope and the facility lighting.	This measure was implemented after completion of the BASE audit.
#4: Geysers Audit (2014)	EEM 4-4: Reduce Operation of the Air-handling Unit	Operate the air-handling unit in HAND mode during the warmest three months of summer and turning it off for the rest of the year when the other fans are adequate to ventilate the space.	This measure has been implemented.
#7: Energy Management Software Investigation (2017)	PI 7-1: SCADA Screens and Instruments to Facilitate Energy Management (formerly PI 1-2: Enhance SCADA Screens)	Add energy monitors, a SCADA energy screen, and other instruments to make energy consumption observable and manageable in real time.	This measure is being implemented as part of the Microgrid project. It should provide operators a more complete picture of real time and historical energy usage at the LTP, and information will help identify additional opportunities for process improvement, increased energy savings, and alert operators to possible adverse trends.
#7: Energy Management Software Investigation	PI 7-2: Monitor Time-of-Use (TOU) Rate Changes	Continue to communicate with our energy suppliers (Pacific Gas and Electric [PG&E] and Sonoma Clean Power [SCP]) to monitor potential changes to TOU schedule.	LTP staff actively manage operations to avoid peak energy usage. The department's Energy & Sustainability (E&S) group meets regularly with PG&E and SCP discusses TOU changes. On August 9, 2018, PG&E received a decision from the California Public Utilities Commission (CPUC) on their proposed New TOU Time Periods. Rates with New TOU Time Periods will be available for commercial customers via opt-in November 2019 through October 2020. New TOU periods will become mandatory for all commercial customers, including Santa Rosa Water, in November 2020.
	PI 7-3: Use the Flow Equalization Basin (FEB) for Peak Shaving	Once a new UV disinfection system is in place, revisit the possibility of using the FEB to store a large proportion of primary effluent during peak summertime demand times, minimizing aeration, RAS pumping, filter pumping, and UV disinfection costs.	Staff currently uses FEBs to the extent possible under existing systems. Staff would augment use of the FEBs for peak shaving if there were an increase in downstream capacity.

Regional Water Reuse Energy Optimization Plan



Tech Memo	Title	Description	Prioritization Rationale
#8: Irrigation System Optimization (2017)	EEM 8-11: Continue Pump Testing Program	Test all reclamation pumps, especially pumps that move a high volume of water and use a large amount of energy.	Reclamation tests pumps on a bi-annual basis using PG&E's free pump testing program, with the support of the E&S team. Pump tests last occurred in 2017.
	EEM 8-13: Transfer Ownership of Vineyard Pumps	Transfer ownership and responsibilities of three pump stations that serve vineyards (Vernazza, JWW, and Hansel) to vineyard owners, in keeping with how the City manages similar facilities.	Transferring ownership and responsibilities is being considered as part of a larger rate study.

Table ES-3. Measures to Not Pursue at This Time

Tech Memo	Title	Description	Prioritization Rationale
#1: LTP Audit (2014)	EEM 1-1: Raise Tertiary Filter Wet Well Level	Increase the wet well level to lower the pumping Total Dynamic Head (TDH). This will result in reduced pump electrical usage. (LTP will install data loggers to determine savings potential.)	This measure is not feasible due to operational constraints. The extent to which the wet well level can be raised is limited by practical considerations, such as increased risk of spillage due to power failures. There is no sub-meter on this pump station, and it has not yet been tested. Staff does not recommend risking bypass of the filters and the resulting consequences.
	EEM 1-3: Raise Raw Wet Well Level	Increase the wet well level to lower the pumping TDH. This will result in reduced pump electrical usage.	Staff tested the efficacy of this measure by raising the wet well level by 10 inches for seven months. However, energy costs increased slightly compared to the previous seven-month period. In addition, higher water levels can increase the risk of spillage and by-pass of the influent screens. The raw wet well level has been returned to its former level.
	EEM 1-4: Modify (3W) Water Scum Spray and Install Variable Frequency Drives (VFDs)	Install VFDs on 3W pumps. Also consider water reduction measures.	Staff modified the water scum spray but will not move forward with VFD installation. The cost to retrofit with VFDs would likely be much higher than K/J projected and would likely exceed potential savings.
	EEM 1-5: Reduce Air to Mixed Liquor and Primary Channel	Shut off or reduce the air to the Mixed Liquor Suspended Solids (MLSS) channel and the primary feed channel.	This measure is not feasible due to operational constraints. Aeration is used to keep solids in suspension. The current flow rate in the Primary Channel is already quite low (0.2 feet per second) and reducing the speed could allow heavier materials to settle.
	PI 1-6: Reduce Sludge Yield	Reduce sludge yield by increasing aeration and/or treatment detention time.	Staff are not confident of potential energy savings from this measure, as comparisons between textbook performance and actual plant performance are fraught with difficulties. This measure would have to be considered as part of a holistic plant process modeling process.

Regional Water Reuse Energy Optimization Plan



Tech Memo	Title	Description	Prioritization Rationale
	EEM 1-7: Optimize Return Activated Sludge (RAS)	Reduce RAS rate. Use state point to ensure minimum RAS rate. Saves energy through reduced RAS and WAS pumping, reduced numbers of GBTs, and also improves secondary performance.	This measure is not feasible due to operational constraints. K/J recommended operating the RAS flow rate in a range from 0 to 4 million gallons per day (MGD) per clarifier. RAS flow rates are already being operated at their full range, which is 2.5 to 3.5 MGD. The system does not have the capacity to expand that range further.
	EEM 1-8: Stagger Digester Mixing Pumps During Peak Period	Consider shutting down the digester mixing pumps for 2.5 hours during the electric rate peak period.	This measure is not desirable because it would reduce energy production, the maximization of which is a priority. Mixing produces more gas which allows for more production of energy.
	EEM 1-9: Install VFDs on Aerated Grit System	Add VFDs to aerated grit blowers. Allow turn-down or pacing at low flows.	This measure is not being implemented because of cost concerns. The cost to retrofit this part of the system would likely be much higher than projected by K/J.
	PI-1-1: Reroute Filter Backwash Water	Reroute the filter backwash water to the head of the plant so that the anthracite lost in the filter backwash is removed by the grit system and does not settle in the primary influent channel.	This measure is infeasible due to the complexities associated with plumbing backwash to the headworks. Staff has implemented a grit capture system.
	PI-1-3: Increase Belt Press Solids Concentration	Increase sludge concentration leaving the belt presses from 14.8% to 18% to reduce the number of truck loads by 9% per year.	The measure is not being implemented because of cost concerns. While higher sludge concentrations are typically more desirable, staff have not confirmed that cost savings from higher sludge concentrations would exceed the costs to achieve that goal.
	PI-1-4: Monitor Primary Sludge pH	Monitor primary sludge pH as a means of checking for sludge septicity.	Staff monitored primary sludge for several days, and pH results indicated somewhat acidic conditions within the sludge. However, process changes to raise the pH would likely result in lower digester detention times, which could potentially restrict the amount of high strength waste the facility can accept. Staff understanding of the impacts and control of primary sludge pH is inadequate to further pursue or critique this recommendation.
#2: Biosolids Compost Facility Audit (2014)	EEM 2-1: Modify Exhaust Fan Operation	Reduce energy consumption by modifying operation of the Compost Facility building exhaust fans instead of replacing them.	Staff will not pursue at this time but would consider in the future. Exhaust fan modifications and ventilation would be considered, depending on future use of the building, and incorporated into a larger project to replace the aging roof, assess the biofilter system, and redesign the exhaust system.
	EEM 2-3: Install Photovoltaic Panels	Install solar PV at the Compost Facility site as part of a Power Purchase Agreement.	Potential sites for solar facilities were evaluated as part of TM#9, and this site was determined to be infeasible. The roof of the building is not designed to hold the kind of weight required by solar, and the land to the north of the biofilter is identified California Tiger Salamander habitat.

Regional Water Reuse Energy Optimization Plan



Tech Memo	Title	Description	Prioritization Rationale
#3: Reclamation System Audit (2015)	EEM 3-3: Eliminate Pressure-Relief Bypass	Connect a hydropneumatic tank at Todd Road Pump Station, in lieu of pressure relief bypass.	The estimated cost of \$36,000 is too expensive to justify the small potential annual return of \$1,200. Payback would take 30 years.
	EEM 3-6: Optimize Time of Use Rates	Optimize the operation of five pumps with the highest electricity use to avoid peak time of use rates.	This measure was deemed infeasible because it would increase the risk of permit violations due to unnoticed runoff or water leaks during the night.
#6: LTP Waste Heat Investigation (2017)	EEM 6-1: Two ORC Generator Units (100 kW) - with SGIP incentive	Use waste heat from Cogeneration Unit #3 to power an <i>Organic Rankine Cycle</i> power generation system, a thermodynamic cycle which converts heat into electricity.	This measure infeasible based on staff concerns that the quality of waste heat is not high enough to run an ORC system. Staff also concurred that the investment costs K/J proposes in the TM (\$975,000) are too low, and that the true savings would not be high enough to justify the cost.
	EEM 6-1: Two ORC Generator Units (100 kW) - without SGIP incentive		
#7: Energy Management Software Investigation (2017)	EEM 7-1: Modify Pump Alternation at LTP	For influent, return activated sludge, and waste activated sludge pumps: instead of equalizing run-time of all the pumps within a system, run the most efficient pumps to minimize energy use.	This measure is unnecessary. Pump tests to date have shown that the pumps are generally uniformly efficient, and not different enough to warrant modifying pump alternation.
	PI 7-4: Optimization of the Turblex Blowers	Confirm that we are utilizing the two fixed-speed Turblex blower in the most energy-efficient mode.	This measure is unnecessary. The Turblex blower system was installed as part of an energy efficiency project. Staff is confident in our use of the system, and do not feel it would be a good use of time or resources to investigate further.
#8: Irrigation System Optimization (2017)	EEM 8-2A: Replace Aggio Pump	Replace 60 horsepower (HP) Aggio centrifugal pump.	This measure is unnecessary. The 2017 pump efficiency test used in K/J's analysis is artificially low because the pump was tested during a period of low flow. A majority of pump operations require a 60 HP motor; staff has considered alternatives (VFD, replacing with 2 pumps, etc.) but has determined that the energy savings would not outweigh the costs.
	EEM 8-7: Replace Hansen East Pump	Replace 30 HP centrifugal pump.	This measure is unnecessary as this pump already has a VFD on it. Additional retrofits would not result in adequate savings to justify the costs.
	EEM 8-10: Replace La Franconi Pipeline Pump	Replace 25 HP centrifugal pump.	This measure is unnecessary. The pump is only 15 HP, which is too small to test under PG&E's current pump efficiency testing program. It uses a small amount of energy and is not worth replacing or retrofitting at this time. Staff will consider replacing the motor and/or pump once the current configuration wears out.

Regional Water Reuse Energy Optimization Plan



Tech Memo	Title	Description	Prioritization Rationale
#9: Comprehensive Solar PV Investigation (2017)	REM 9-1 and 9-2: 1 MW Solar PV Installation, Ground Mounted - Own and Operate	Install 1MW of solar PV panels at 4220 Walker Avenue. Own and operate the facility and use the electricity.	This project was rejected because it is more costly than alternative solar systems considered (REM 9-4) and would impact endangered species habitat. Total costs are estimated at almost \$4 million dollars, including approximately \$900,000 of costs associated with California Environmental Quality Act (CEQA) analysis and California Tiger Salamander (CTS) mitigation. CEQA and CTS mitigation are not required under floating solar options.
	REM 9-3: 1 MW Solar Installation, Ground Mounted - PPA	Install 1MW of solar PV panels at 4220 Walker Avenue using a Power Purchase Agreement. SRW would use the electricity.	This project was rejected because it is more costly than alternative solar systems considered (REM 9-4) and would impact endangered species habitat. Total costs are estimated at almost \$1 million dollars, including approximately \$900,000 of costs associated with CEQA analysis and CTS mitigation. CEQA and CTS mitigation are not required under floating solar options.
#10: Mechanical Digester Mixing Investigation (2017)	EEM 10: Mechanical Digester Mixing (also PI 1-5: Upgrade Digester Mixing)	Replace existing gas mixing system in Digesters 3 and 4 with externally-pumped mixing system.	This measure will not be pursued at this time because of cost concerns. Despite the 8% return on investment calculated in the TM, it is unlikely that the externally-pumped system evaluated in the TM will ever be cost effective based on power savings alone, especially given the overly optimistic additional gas production assumed in the analysis. There are other mixing technologies available that could be more effective and cheaper to install. Staff will consider researching other possible solutions to improving mixing efficiency, such as (but not limited to) internal propellers, gas lifted draft tubes, plunger-style mixers, or efficient low energy mixers.

Table ES-4. Measures Not Recommended

Tech Memo	Title	Description	Prioritization Rationale
#2: Biosolids Compost Facility Audit (2014)	EEM 2-2: Change Compost Screen Location	Reduce fuel consumption and labor associated with moving compost to the screening equipment.	This measure is not practical due to the configuration of the screener. Relocation would cause additional workload on the loader and the need to install push walls for the fines and overs coming off the screener. In addition, the plastics bin would be trapped between the conveyors and the overs pile making it very difficult, if not impossible, for the bin to be picked up by the

Regional Water Reuse Energy Optimization Plan



			hauling company.
	EEM 2-4a: Cover the Biosolids Storage Area	Reduce wetting of uncovered biosolids to increase the overall average solids concentration of the biosolids being composted each year.	This measure is not cost effective. The City has changed the process for storage and putting biosolids in the pond storage area is now the last resort. Now staff wait until the very end of the season to put it there, which reduces exposure to moisture.
	EEM 2-4b: Change Dewatering Process	Change how the Compost Facility removes the water from the biosolids, to achieve dryer biosolids.	The audit does not identify alternatives for changing the dewatering process, it only shows potential cost savings. Per Zach Kay, taking out the belt presses and replacing them would be very expensive.
TM #3: Reclamation System Audit (2015)	EEM 1: Produce Two Recycled Water Qualities	Provide a secondary treatment process for a different type of treated water than is already provided by the LTP.	This measure is too costly for only getting a small amount of recycled water. It also adds operational complexities.
	EEM 4: Incorporate VFDs	Provide electricity consumption reductions for a pump station by installed VFS to vary frequency and speed of pump to maintain desired operating conditions.	Energy savings with installation of VFD is conditional to the size and capacity of the pump. Thus, smaller pumps would not experience the same energy efficiency.
TM #3a: Reclamation System Audit (2015)	EEM 8: New Hydropneumatic Tank on West College Section of the Transmission Main	Objective is to eliminate excess discharges to the West College reservoir during periods of low demand.	This measure is not cost effective.
	EEM 9: New Hydropneumatic Tank on Laguna Section of the Transmission Main	Eliminate excess discharges via MOV-B1B during periods of low demand.	This measure is not cost effective.
	EEM 10: Common Hydropneumatic Tank for Laguna and West College Transmission Main Summary	Eliminate excess discharges via MOV-B1B or the overflow weir at West College reservoir, during periods of low demand.	This measure is not cost effective.
	EEM 11: Operate Laguna and West College Transmission Mains at Common HGL without a Hydropneumatic Tank	Eliminate excess discharges via MOV-B1B or the overflow weir at West College reservoir, during periods of low demand.	The viability of this measure is dependent on the maximum allowable pressure for the transmission main, which could not be verified for this study.

Regional Water Reuse Energy Optimization Plan



TM #4: Geysers Energy Audit (2014)	EEM 2: Replace Existing 800 HP Pump with More Efficient Unit	Would add smaller pump (650 HP) that is hydraulically optimized to deliver 17 MGD when pumping in parallel with the existing 1250 HP unit.	This measure is not cost effective.
	EEM 3: Optimize Pump-Control Logic	Start second 1250 HP unit when demand exceeds supply from single 1250 unit. Both pumps would ramp up and down in unison to match demand, improving efficiency slightly.	This measure is not cost effective.
TM #6: LTP Waste Heat Investigation (2017)	EEM 6-2: Large Replacement Absorption Chiller	Replace two existing evaporative coolers with one large 200-ton absorption chiller.	This measure is not cost effective.
TM #8: Irrigation System Optimization Investigation (2017)	EEM 8-1: Replace Dotti Pump	Replace Dotti Pump with an optimized unit of the same size that could provide an OPE of at least 69% (up from 56%).	This measure is not cost effective.
	EEM 8.2B: Replace Gleason/Nahmen Pump	Replace Gleason/Nahmen pump with an optimized unit of the same size that could provide an OPE of at least 69% (up from 56%).	This measure is not cost effective.
	EEM 8-3: Replace Carinalli 1 Pump	Replace Carinalli pump with an optimized unit of the same size that could provide an OPE of at least 69% (up from 56%).	This measure is not cost effective.
	EEM 8-4: Replace La Franconi Pond Pump	Replace La Franconi Pond pump with an optimized unit of the same size that could provide an OPE of at least 69% (up from 55%).	This measure is not cost effective.
	EEM 8-5: Replace Dei South Pump	Replace Dei South pump with an optimized unit of the same size that could provide an OPE of at least 69% (up from 53%).	This measure is not cost effective.
	EEM 8-6: Replace Beretta South Pump	Replace Beretta South pump with an optimized unit of the same size that could provide an OPE of at least 69% (up from 53%).	This measure is not cost effective.
	EEM 8-8: Replace Mello East Pump	Replace Mello East pump with an optimized unit of the same size that could provide an OPE of at least 69% (up from 60%).	This measure is not cost effective.
	EEM 8-9: Replace Matos Cheese Factory Pump	Replace Matos Cheese Factory pump with an optimized unit of the same size that could provide an	This measure is not cost effective.

Regional Water Reuse Energy Optimization Plan



	EEM 8-11: Control Pumping during Summer On-Peak Periods	<p>OPE of at least 69% (up from 55%).</p> <p>Install controls at each reclamation pump that serves an end user recycled water. Controls would only allow pumps to operate during periods when electricity is significantly less expensive.</p>	<p>This measure is operationally infeasible. Pump size, available irrigation equipment, and customers' need to irrigate during daylight hours all limit the ability to irrigate during off-peak hours.</p>
--	---	--	--

December 31, 2014

Technical Memorandum #1

To: Mike Prinz, Joe Schwall, and Colin Close– City of Santa Rosa

From: Brad Musick, Process Audit Lead, Wastewater Solutions, Inc.
Tom Gorman, Construction Services Manager, Kennedy/Jenks
Dawn Taffler, Reclamation Audit Lead, Kennedy/Jenks
Alan Zelenka, Kennedy/Jenks Project Manager
Julia Lund, Kennedy/Jenks Deputy Project Manager

Subject: Task 1.1 – Laguna Wastewater Treatment Plant (LTP) Process Energy Audit
Santa Rosa Energy Optimization Plan (EOP) - Phase 1
K/J Project: 1368024*01

Kennedy/Jenks Consultants (KJ) conducted a process energy audit of the City of Santa Rosa (Santa Rosa) Laguna Wastewater Treatment Plant (LTP) on April 10 and 11, 2014. The purpose of the process energy audit was to identify and recommend cost-effective Energy Efficiency Measures (EEMs) and Process Improvements (PI) that can be achieved primarily through changes in plant operations and process. EEMs are recommended changes that would result in energy savings, while PIs are recommended changes that may be beneficial to plant personnel or performance but do not necessarily result in direct energy savings.

1.1 Recommendations

Overall, the audit found that LTP is well operated and maintained and is in the top-tier nationally in its performance and practices. There was no “low-hanging fruit” in terms of energy savings. LTP exceeds normal industry standards.

- The average electrical rate for LTP plant is \$0.1095 per kilowatt hour (kWh).
- The off-peak energy rate (6 pm to noon) is approximately \$0.07 per kWh, and the on-peak energy rate (noon to 6 pm) jumps to \$0.13 kWh (which was referred to by LTP staff as the “high cost period”). The highest electric demand charge is during summer peak between May 1 and October 31.

A total of 10 EEMs were identified during the audit and are shown in Table 1-1. Most of the recommendations only require operational or SCADA changes, making these EEMs very cost-effective.

Table 1-1: List of Recommended Energy Efficiency Measures

EEM#	Title
1	Raise Tertiary Filter Wet Well Level
2	Replace Ultraviolet (UV) Disinfection
3	Raise Raw Wet Well Level
4	Modify (3W) Water Scum Spray and Install VFDs
5	Reduce Air to Mixed Liquor and Primary Channel
6 ¹	Run Idle Cummins Engines on Natural Gas to Generate Electricity
7	Optimize Return Activated Sludge
8	Stagger Digester Mixing Pumps During Peak Energy Period
9	Install VFDs on Aerated Grit System
10	Implement Building and Lighting EEMs

¹ EEM-6 is not included in the overall total savings.

Before and after electrical readings on select equipment and/or operational trials would allow a more refined projection of estimated annual savings. It should be noted that demand charges were also not included in the potential savings, though time of day charges were where applicable. Data loggers and/or electrical readings over a period of time would be needed to accurately determine the potential demand savings. Since the process audit recommendations are mostly based on changes to process set-points and standard operating procedures, demand savings cannot be estimated until the recommended changes have been made or tested. Calculated values are based on rough order of magnitude estimates and what is believed to be the best available data. The cost estimates are based on the Association for the Advancement of Cost Engineering International (ACEI) standards for cost estimating accuracy of +50% and -30%.

Should Santa Rosa implement all of the recommendations in this Tech Memo, it could achieve in an estimated average annual net savings of nearly \$250,000 per year with a Net Present Value (NPV) of the cumulative average annual savings of \$2.99 million. This does not include EEM-6 "Run Idle Cummins Engines on Natural Gas to Generate Electricity," which was not included in the savings totals because this recommendation came from a 2013 Brown and Caldwell study and was not solely a KJ recommendation. In addition, excluding EEM-2 Replacement of the UV Disinfection System, the electricity savings are still over 734,000 kWh per year, with an average annual net savings of about \$124,000 and NPV of cumulative net savings of over \$1.76 million. PG&E incentives are based on the capital cost and energy savings of an EEM. For projects without capital cost, such as nearly all of the recommended EEMs, PG&E would not offer an incentive. The UV project may be eligible for a substantial incentive, but to be conservative we did not include an incentive in this analysis.

The savings shown in Table 1-2 below illustrates only the potential savings that can be estimated with available information.

Table 1-2: Summary of Recommended Energy Efficiency Measure Savings

Electricity Savings (kWh/Yr)	Demand Savings (kW)	GHG Emission Reduction (MT/Yr)	Capital Cost (\$)	Incentive Amount (\$)	Net Cost (\$)	Avg Annual Net Savings (\$/Yr)	NPV of Cumulative Net Savings ¹ (\$)
6,890,700	\$785,000	1,416	\$12,377,900	\$1,000	\$12,376,900	\$248,500	\$2,993,500
TOTAL without EEM-2: Replacement of the UV Disinfection System							
734,469	\$83,641	151	\$3,000	\$1,000	\$2,000	\$124,385	\$1,762,210

¹ Based on a 4.0% loan/bond rate, 1.0% loan/bond issuance cost, 2.5% inflation rate, 3.1% real discount rate and 5.7% nominal discount rate. Time period ranges from 10 to 20 years, depending upon the EEM.

The priority order for implementation by Santa Rosa is based on the Return on Investment (ROI) for each recommended EEM. ROI is calculated using the Excel IRR function but cannot be calculated if the capital cost is zero ("NC" represents "not calculable" in Table 1-3 below). Essentially, the ROI is infinite without capital costs; therefore, EEMs with zero capital cost are ranked based on the amount of NPV of cumulative net savings it brings to Santa Rosa. The recommended implementation order is in Table 1-3.

Table 1-3: Priority Implementation Order for Energy Efficiency Measures

Rank	EEM #	Title	ROI %	NPV of Life of Savings (\$1,000)
1	EEM 6	Run Idle Cummins Engines on Natural Gas to Generate Electricity	IDTD ¹	\$1,743
2	EEM 5	Reduce Air to Mixed Liquor and Primary Feed Channel	NC ²	\$685
3	EEM 7	Optimize Return Activated Sludge	NC ²	\$447
4	EEM 8	Stagger Digester Mixing Pumps During Peak Period	NC ²	\$262
5	EEM 1	Raise Tertiary Filter Wet Well Level	NC ²	\$230
6	EEM 3	Raise Raw Wet Well Level	NC ²	\$96
7	EEM 4	Modify 3W Water Scum Spray and Install VFD	NC ²	IDTD ¹
8	EEM 10	Implement Building and Lighting EEMs	NC ²	IDTD ¹
9	EEM 9	Install VFDs on Aerated Grit System	110%	\$43
10	EEM 2	Replace Ultraviolet (UV) Disinfection	9%	\$1,231

¹ IDTD - Insufficient Data To Determine at this time

² NC = Not calculable because the ROI for projects with zero capital cost do not calculate using the Excel IRR function. With zero capital cost the ROI is essentially infinite.

In addition to the ten EEMs six PIs were also identified. Since PI recommendations do not directly result in energy savings, no cost savings were identified in the tech memo for these suggestions. They are listed in Table 1-4 below.

Table 1-4: List of Recommended Process Improvements

PI#	Title
1	Reroute Filter Backwash Water
2	Enhance SCADA Screens
3	Increase Belt Press Solids Concentration
4	Monitor Primary Sludge pH
5	Upgrade Digester Mixing
6	Reduce Sludge Yield

1.2 Background

1.2.1 Plant Description

LTP is a tertiary wastewater treatment facility with an average flow of 22.0 million gallons per day (MGD). The plant processes investigated for this audit task include:

- Headworks Screening and Grit Removal
- Primary Treatment
- Activated Sludge with Anoxic Selector
- Tertiary Filtration
- UV Disinfection
- Solids Handling
- Anaerobic Digestion

1.2.2 Energy Use and Cost

As part of the data collection prior to the onsite audit, Santa Rosa provided baseline energy usage for its Subregional System, including LTP. The baseline provides a snapshot of how much energy is currently used at LTP to allow for comparison to what impacts the various audit recommendations will have. The baseline energy profile for LTP includes electricity use and natural gas use.

KJ worked with Santa Rosa staff to collect the necessary data to create the baseline in a spreadsheet model entitled "Santa Rosa Energy Baseline." Baseline data were developed using daily operating data from the Santa Rosa SCADA system and monthly billing data from PG&E for the period of January 2012 through December 2013.

For LTP, the electricity baseline was broken down by process as shown in the SCADA data, as shown in Table 1-5.

Table 1-5: Baseline Electricity Usage for LTP

Process Category	Baseline Annual Electricity Use (kWh/Yr)¹	Baseline Annual Electricity Cost (\$/Yr)
Influent Pumping	1,355,000	\$86,000
Primary Treatment ²	409,000	\$29,000
Aeration	5,616,000	\$365,000
UV Disinfection	9,678,000	\$619,000
W3 Pumping	860,000	\$55,000
Activated Sludge ³	1,278,000	\$81,000
Miscellaneous On-Site ^{4,5}	7,614,000	\$486,000
Total Electricity Used at LTP	26,617,000	--
Electricity Generated On-Site	11,020,000	--
Total Electricity Purchased from PG&E⁵	15,597,000	\$1,707,000

¹ Unless otherwise noted, data are from Santa Rosa SCADA system from Jan 2012 to Dec 2013.

² Includes 2013 data only. This category was not tracked separately until Dec 2012.

³ Includes mixed liquor recycled pumps and anoxic mixers.

⁴ Includes solids handling, lighting, HVAC, and an extremely small amount of usage for Alpha Pond, Waste Management, and Sewer Meter Station.

⁵ Data are from PG&E from Jan 2012 to Dec 2013.

Monthly electricity usage for LTP by process category is shown in Figure 1-1. As illustrated in the figure, the UV system uses the greatest amount of electricity. Other large uses are the combined solids handling, lighting and HVAC category, and aeration.

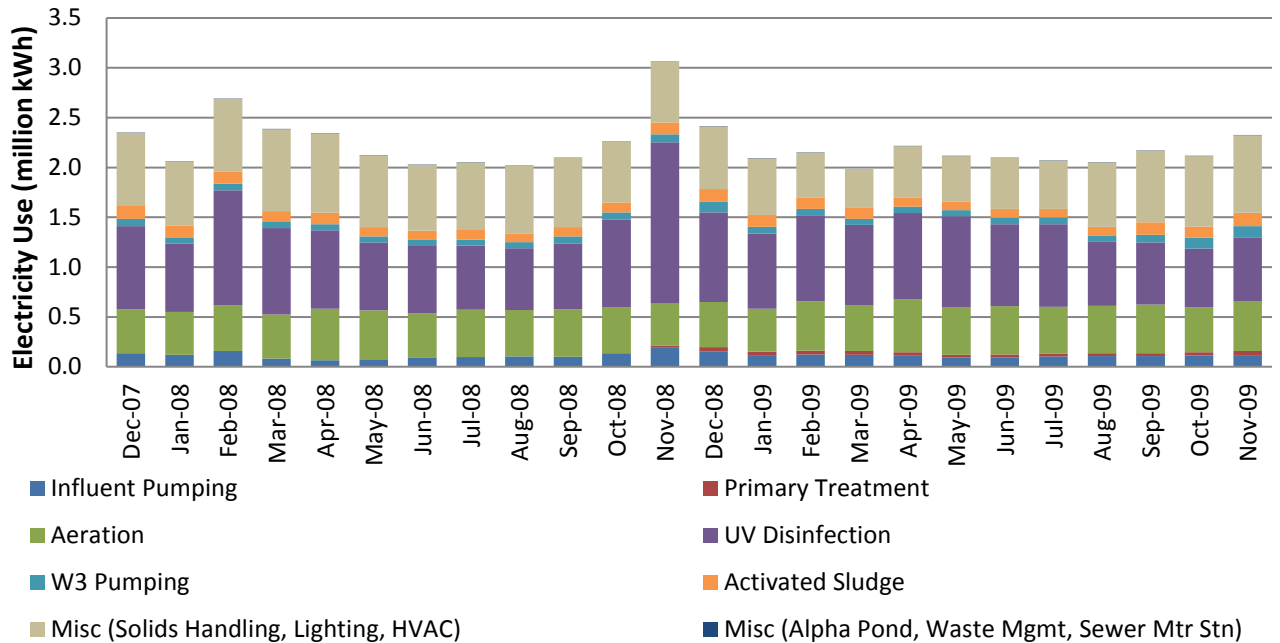

Figure 1-1: Monthly Electricity Usage for LTP by Process Category

As shown in Figure 1-2, LTP uses 75% of the total electricity of the Subregional System.

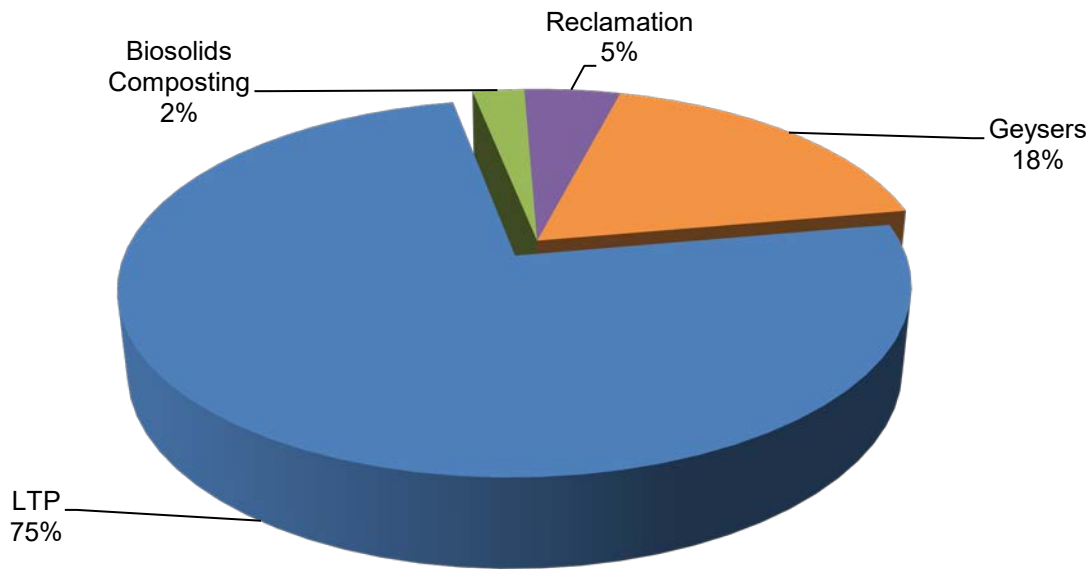

Figure 1-2: Annual Electricity Usage for Subregional System by Category

The natural gas data are broken into Core and Non-Core categories by PG&E. The annual Non-Core data are shown separately for 2012 and 2013, since the CHP project came online in early 2013 and

reduced the natural gas usage significantly. The post-CHP numbers are expected to be representative of future natural gas purchases. The baseline natural gas usage for LTP is shown in Table 1-6.

Table 1-6: Baseline Natural Gas Usage for LTP

Process	Baseline Annual Natural Gas Use (therms/Yr)	Baseline Annual Natural Gas Cost (\$/Yr)
Core	55,000	\$45,000
<i>Non-Core (2012, pre-CHP)</i>	<i>639,000</i>	<i>\$26,000</i>
Non-Core (2013, post-CHP)	150,000	\$10,000
Total Natural Gas Purchased from PG&E (post-CHP)	205,000	\$55,000

1.3 Overview of Audit Methodology

The process energy audit consisted of both an off-site review of data and an on-site tour of LTP. The objective of the on-site tour was to understand the plant history and processes, participate in a guided walk-through of the plant to identify all of the processes and equipment that use energy, provide a detailed assessment of energy using equipment, quantify their energy use, and identify preliminary EEMs.

After the tour, a process energy audit workshop was held at LTP. The goal of the workshop was to examine ideas developed during the offsite data review and utilize LTP staff's significant plant-specific knowledge to develop additional money saving and process related recommendations. Wastewater Solutions, Inc. (WSI) and KJ met with Joe Schwall (LTP Operations Superintendent) and Terry Schimmel (LTP Maintenance Superintendent).

Table 1-7 below shows the summary of the analysis of the 10 identified EEMs. A more detailed description of each recommendation is provided in the following sections. Cost savings spreadsheets were developed for the EEMs where we could quantify the savings and costs and are provided electronically.

Table 1-7: Summary of Identified Energy Efficiency Measures

EEM #	Title	Energy Savings (kWh/Yr)	Avg Annual Net Savings (\$/Yr)	NPV of Life of Savings (\$)	Description
EEM 1	Raise Tertiary Filter Wet Well Level	95,776	\$16,239	\$230,081	Increase the wet well level to lower the pumping TDH. This will result in reduced pump electrical usage. (LTP will install data loggers to determine savings potential.)
EEM 2	Replace Ultraviolet (UV) Disinfection	6,156,296	\$124,093	\$1,231,297	Switching to hypochlorite could result in significant savings from reduced electrical usage (equivalent to 920 HP/day).
EEM 3	Raise Raw Wet Well Level	39,907	\$6,766	\$95,867	Increase the wet well level to lower the pumping TDH. This will result in reduced pump electrical usage.
EEM 4	Modify 3W Water Scum Spray and Install VFD	IDTD	IDTD	IDTD	Install VFDs on 3W pumps. Also consider water reduction measures.
EEM 5	Reduce Air to Mixed Liquor and Primary Channel	285,000	\$48,324	\$684,650	Shut off or reduce the air to the Mixed Liquor Suspended Solids (MLSS) channel and the primary feed channel.
EEM 6	Run Idle Cummins Engines on Natural Gas to Generate Electricity	3,135,000	\$209,691	\$1,743,110	Utilize natural gas to run other generators and reduce purchase of electricity off the grid.
EEM 7	Optimize Return Activated Sludge	186,246	\$31,579	\$447,416	Reduce RAS rate. Use state point to ensure minimum RAS rate. Saves energy through reduced RAS and WAS pumping, reduced numbers of GBTs, and also improves secondary performance.
EEM 8	Stagger Digester Mixing Pumps During Peak Period	108,916	\$18,467	\$261,647	Consider shutting down the digester mixing pumps for 2.5 hours during the electric rate peak period.

EEM #	Title	Energy Savings (kWh/Yr)	Avg Annual Net Savings (\$/Yr)	NPV of Life of Savings (\$)	Description
EEM 9	Install VFDs on Aerated Grit System	18,625	\$3,009	\$42,551	Add VFDs to aerated grit blowers. Allow turn-down or pacing at low flows.
EEM 10	Implement Building and Lighting EEMS	IDTD	IDTD	IDTD	BASE energy equipment audit indicated energy savings opportunities in the building envelope and the facility lighting.
	Totals (Not including EEM-6)	6,890,765	\$248,478	\$2,993,507	

IDTD - Insufficient Data To Determine

2012 BASE Equipment Audit

At the site workshop, Santa Rosa's prior energy audit with Pacific Gas and Electric (PG&E) was briefly discussed. In June 2012 Santa Rosa participated in a Large Integrated Energy Audit Program (LIA) with PG&E's Customer Energy Efficiency (CEE) Department in conjunction with Base Energy, Inc. (BASE). The Audit resulted in the issuance of Report No. BASE_PGE_11-05.

Five "Other Measures Considered" (OMCs) were evaluated in the report and are listed in Table 1-8 below. These measures were not included in the Energy Efficiency Opportunities (EEOs) section due to simple payback periods greater than 10 years.

Table 1-8: Energy and Cost Savings Summary for Other Measures Considered

OMC No. Description	Energy Savings (kWh/Yr)	Peak Demand Savings (kW)	Energy Cost Savings (\$/Yr)	Implementation Cost (\$)	Potential Incentive (\$)	Simple Payback w/ Incentive (Yrs)
Install a Low-Pressure High-Intensity Ultraviolet (UV) Radiation Disinfection System	5,893,987	482.7	\$505,968	\$14,000,000	\$578,729	26.5
Install Mechanical Pumping Sludge Mixing Systems in the Anaerobic Digesters	175,310	20.0	\$15,140	N/A	\$17,778	N/A
Install High Efficiency Pumps	133,122	15.2	\$11,496	\$306,953	\$13,501	25.5
Install More Efficient Water-Cooled Chillers	66,913	20.3	\$7,027	\$130,706	\$12,066	17
Install High Efficiency Fans	73,757	8.4	\$6,370	\$188,020	\$7,480	28
Total	6,343,089	546.6	\$546,001	\$14,625,679	\$629,554	25.6

Five EEOs, which are considered economical, have been analyzed in this report and are listed in the Energy Efficiency Opportunities (EEOs) Table 1-9.

Implementation of these EEOs could result in the following savings:

- Electrical energy savings of 353,350 kWh per year representing 1.0% of the facility's electrical energy consumption (1.7% of electrical energy procured from PG&E).
- Peak demand savings of 36.9 kW.
- No natural gas energy savings expected for any of the measures.
- Potential cost savings of \$31,434 per year representing 1.4% of the facility's total annual energy costs.
- Total potential incentives and rebates of \$26,699.
- Total installed cost with incentives and rebates of \$134,546.
- Overall simple payback period with incentives and rebates of 4.3 years.

Table 1-9: Summary of BASE Energy Efficiency Opportunity Costs and Savings

EEO	Measure Description	Energy, Cost and GHG Savings					Project Costs, Incentives, and Payback			
		Peak Savings (kW) **	Electricity (kWh/Yr)	Natural Gas (Therms /Yr)	Annual Cost Savings (\$/Yr)	CO2 Saved (Tons /Yr)	Estimated Installed Cost (\$)	Potential PG&E Incentive (\$)	Net Measure Cost (\$)	Pay-back Period (Yrs)
EEO-1 ¹	Optimize Control of Filter Influent Pumps to Increase Pumping System Efficiency	0.0	48,810	0	\$4,218	14.0	\$3,600	\$4,393	-\$793	0.0
EEO-2	Widen Deadband Between Cooling and Heating Setpoint Temperatures and Setback Zone Temperatures During Unoccupied Hours for Compost Facility Offices	0.0	12,558	0	\$943	3.6	\$0	\$0	\$0	0.0
EEO-3 ¹	Install Automatic Lighting Controls	0.0	59,112	0	\$5,149	17.0	\$10,903	\$2,931	\$7,972	1.5
EEO-4	Install a More Efficient VFD Air Compressor	5.2	45,534	0	\$3,933	13.1	\$22,031	\$4,618	\$17,413	4.4
EEO-5	Install High Efficiency Fluorescent Lighting in Various Areas	31.7	187,336	0	\$17,191	53.9	\$124,711	\$14,757	\$109,954	6.4
Recommended EEM Totals		36.9	353,350	0	\$31,434	101.6	\$161,245	\$26,699	\$134,546	4.3

¹ Already implemented (Joe Schwall comments 12-11-14)

1.4 Detailed Descriptions of Recommended Energy Efficiency Measures

EEM-1: Raise Tertiary Filter Wet Well Level

Treated wastewater is pumped from the tertiary wet well through the tertiary filters. Raising the wet well level by 2 feet (and up to 3 feet) would lower Total Dynamic Head (TDH) by approximately 10% and reduce pumping energy. An estimate of energy savings for this EEM is based on the Raw Wet Well test done by LTP staff that raised the well 10 inches. This estimate for raising the well two feet is proportional to that estimated savings and is presented in the table below. To more accurately determine the potential savings, data loggers would need to be installed on the system, which Joe Schwall (LTP Operations Manager) indicated that he would do in the future.

Raising the well level would likely be a seasonal optimization measure. With increased wet weather flows, there would be a greater risk of bypass of the tertiary filters due to overflow. During the dry months an off-line clarifier is available for overflow protection. The wet well set point is controllable through SCADA and can be set to automatically adjust to the desired wet well level based on influent flow conditions.



Figure 1-3: Tertiary Filter Wet Well Pumps

Table 1-10: EEM-1 Raise Tertiary Filter Wet Well Level Summary

Electricity Savings (kWh/Yr)	Electricity Savings (\$/1st Yr)	GHG Emission Reduction (MT/Yr)	Capital Cost (\$)	Incentive Amount (\$)	Net Cost (\$)	Avg Annual Net Savings (\$/Yr)	NPV of Cumulative Net Savings (\$)
95,776	\$10,907	20	\$0	\$0	\$0	\$16,239	\$230,081

EEM-2: Replace Ultraviolet (UV) Disinfection

The objective of this EEM is to reduce energy consumption by exploring options to replace the use of UV disinfection with a less energy intensive disinfection option.

Santa Rosa has taken several steps to meet stringent discharge compliance requirements set by the Regional Water Quality Control Board (RWQCB), including minimizing discharge when possible and modifying the disinfection process at LTP to eliminate disinfection byproducts (DBPs) within the reclamation system. Prior to 2000, Santa Rosa used gaseous chlorine for disinfection. As the quantity of chlorine needed to meet water quality requirements increased and DBPs became a regulatory concern, Santa Rosa changed their treatment process from chlorination to UV in 2000. The switch to UV increased the energy use at LTP and resulted in the occurrence of increased biological growth in the recycled water conveyance system due to the lack chlorine residual.

The UV system realized capacity is approximately half of the stated design. Each bank of UV channels uses approximately 1 MW of electricity or 27,000 kWh per day. Currently LTP spends on average \$80,000 per month (\$960,000 per year) for UV electricity.



Figure 1-4: UV Disinfection Equipment

Santa Rosa is currently exploring alternatives for disinfection, including chlorination and pasteurization, to address deficiencies in the current UV system. For the purpose of this analysis, it is assumed that chlorination would be used in place of UV, although Santa Rosa may select another form of disinfection in the future. Based on a preliminary discussion with Santa Rosa, an alternative chlorination system could include one of the following:

- 1) Use existing (mothballed) chlorine contact chamber (CCC) located next to UV.
- 2) Construct a facility to inject chlorine or hypochlorite at an alternative location.
- 3) Construct a new CCC in the northern area of LTP.

EEM-2 considers four options for reducing the use of UV disinfection at LTP, as described in the following sections. Complete replacement of UV with chlorination is not considered at this time due to the sensitivity of DBPs present in the discharge from Delta Pond to the Laguna de Santa Rosa.



Figure 1-5: LTP and Meadow Lane Pond

Option 1: Separate Geysers from UV

Deliveries to the Geysers Steamfield account for approximately two thirds of the recycled water produced at LTP. Switching the Geysers flow from UV to chlorination would reduce approximately two thirds of the electricity usage. Physically, this could be achieved by installing a pipeline to convey the disinfected water from an alternative disinfection facility at LTP to the Geysers Llano Pump Station across the street. A new pump station may also be required to convey disinfected effluent to Llano Pump Station, depending on the location of the new disinfection facilities. The main reclamation water transmission line to agricultural and urban customers would still convey UV disinfected water year-round.

One challenge to this approach is maintaining a steady rate of flow to Llano pump station during periods when LTP is receiving low flows. The Geysers steam fields cannot accommodate changes in flow greater than 2 MGD because exceeding this value is linked to an increase in seismic activity in that region.

Option 2: Seasonal Chlorination

The switch to seasonal chlorination could reduce energy costs while maintaining UV disinfection during the discharge season (October 1 to May 15) when the formation and release of DBPs to the Laguna de Santa Rosa are a concern. It should be noted that Santa Rosa actively manages the Reclamation System to avoid discharge and no significant discharge has occurred from 2012 to 2014. Chlorination of recycled water would occur during the summer, and the UV system would be turned off during this period. The entire flow leaving LTP would be treated with chlorine using the existing CCC. During the winter season, when treated effluent is being stored, the UV system would be turned on.

Option 3: Separate Geysers from UV and Seasonal Chlorination

This option combines options 1 and 2, decreasing the overall UV usage year-round. The Geysers System would receive chlorinated water year-round and agricultural and urban users would receive chlorinated water in the summer. UV disinfection would be reserved for periods when treated effluent is being stored.

Option 4: UV Prior to Discharge Only

This option minimizes the use of UV to the greatest extent by predicting when discharge would be needed and only turning on the UV system in advance of required discharge. The challenges for this scenario are: predicting when discharge will be needed and predicting the time period necessary to ensure that DBPs would not be present in Delta Pond when discharge is needed.

Randy Piazza indicated that Santa Rosa has some general guidelines for predicting when discharge is required:

- Santa Rosa aims to maintain between 1.0 and 1.1 billion gallons (of the 1.4 billion gallon storage) prior to discharge.
- 17 MGD is delivered to the Geysers Steamfield in the winter, thus Santa Rosa needs to maintain 1 billion gallons in storage to meet Calpine contract delivery requirements if there is no storm flow and only waste water.

Regarding the formation and attenuation of DBPs, additional evaluation would be needed to understand:

- The degree of formation of DBPs based on the selected chlorination practice.
- The extent of attenuation or volatilization of DBPs expected in a reservoir like Delta Pond (i.e., through surface aeration)
- The RWQCB permitting requirements that would need to be met to support the use of chlorination during the winter discharge season.
- An approach to demonstrate that control of DBPs in the disinfection system will be adequate and the UV system could be turned on in time to eliminate or minimize risk of discharging DBPs.
- Potential need for a bench-scale or pilot-scale testing program to demonstrate a recommended approach.

Summary of Options for UV Reduction

Table 1-11 summarizes the pros and cons of the above four options for UV reduction.

Table 1-11: Summary of EEM #2- UV Reduction Options

Option #	Description	Pro	Con
1	Separate Geysers from UV	<ul style="list-style-type: none"> Proximity and ease to separate Geysers from UV by adding a short pipeline from LTP to Llano Pump Station (PS) Energy savings on disinfection for 2/3 of LTP flow Year-round Potential reuse of decommissioned CCC 	<ul style="list-style-type: none"> Requires maintaining two independent of disinfection systems Need for infrastructure to connect tertiary RW from new disinfection to Geysers PS Confirm Calpine contract will accept switch from UV to chlorination for RW supply
2	Seasonal Chlorination	<ul style="list-style-type: none"> Energy savings during summer high usage periods on disinfection for 100% of LTP flow Potential reuse of decommissioned CCC 	<ul style="list-style-type: none"> Only provides energy savings in the summer period Potential residual DBPs in Delta Pond at start of winter discharge season
3	Separate Geysers from UV and Seasonal Chlorination	<ul style="list-style-type: none"> Energy savings on disinfection for 2/3 of LTP flow in the winter plus 100% of LTP flow in the summer Potential reuse of decommissioned CCC No need for additional infrastructure to separate Geysers from UV system 	<ul style="list-style-type: none"> Requires maintaining two independent of disinfection systems, with only limited UV use Confirm Calpine contract will accept switch from UV to chlorination for RW supply Potential residual DBPs in Delta Pond at start of winter discharge season
4	UV Prior to Discharge Only	<ul style="list-style-type: none"> Energy savings on disinfection for 100% of LTP flow year-round, with the exception of discharge years. Potential reuse of decommissioned CCC 	<ul style="list-style-type: none"> Requires maintaining two independent of disinfection systems, with only limited UV use Confirm Calpine contract will accept switch from UV to chlorination for RW supply Potential residual DBPs in Delta Pond at start of winter discharge season Challenge to obtain RWQCB buy-in for addressing DBPs in winter discharge season

As described in Table 1-11 above, there are numerous issues that would need to be resolved prior to implementing an alternative disinfection strategy. Additional analysis would be also needed to evaluate the type, capacity, location and associated internal pumping and piping required to implement an alternative disinfection facility.

However, if the plant were to implement Option #1; electricity use and cost for UV disinfection would be reduced by roughly two-thirds. Construction would include a new hypochlorite tank, a building, dosing equipment, and other appurtenances. A rough estimate of the capital needed is approximately \$10 million, but this amount would need to be refined once a preliminary design has been done. In addition, by switching to hypochlorite disinfection it is estimated that between 550 and 1,000 pounds per day of chemical would be required. At \$1.05 per pound, the estimated additional chemical cost would be between \$580 and \$1,000 per day. In addition, a chlorine system upgrade would require a major capital project. Assuming a reduction of two-thirds of the electricity use, \$10

million capital cost and \$1,000 per day in chemical cost; it is estimated that a hypochlorite disinfection system in Option #1 would save Santa Rosa an average of \$124,000 per year compared to the current UV system, with a NPV of cumulative net savings of nearly \$1.23 million. The UV project may be eligible for a substantial incentive (approximately \$492,000 if all the capital costs were eligible and the savings estimate were verified), but to be conservative we did not include an incentive in this analysis.

Table 1-12: EEM-2 Replace UV Disinfection Summary

Electricity Savings (kWh/Yr)	Electricity Savings (\$/1st Yr)	GHG Emission Reduction (MT/Yr)	Capital Cost (\$)	Incentive Amount (\$)	Net Cost (\$)	Avg Annual Net Savings (\$/Yr)	NPV of Cumulative Net Savings (\$)
6,156,296	\$701,079	1,265	\$12,375,893	\$0	\$12,375,893	\$124,093	\$1,231,297

EEM-3: Raise Raw Wet Well Level

Similar to EEM-1, increasing the raw wet well level would reduce the pumping TDH. Joe Schwall tested the system by raising the wet well level by 10 inches and calculated a flow-normalized daily electrical savings based on an annual average flow of 22 MGD to be 164 kWh/day. The plant may not be able to run at this higher wet well level during the higher flow winter months without flowing onto the deck and partially bypassing over an isolation gate into the manual screen channel. Assuming the raw wet well level could be raised for eight months of the year with electricity savings of 39,900 kWh per year, the average annual net savings is estimated to be over \$6,700 per year, and the NPV of cumulative net savings is nearly \$96,000.

The wet well set point is controllable through SCADA and can be set to automatically adjust to the desired wet well level based on influent flow conditions.

Table 1-13: EEM-3 Raise Raw Wet Well Level Summary

Electricity Savings (kWh/Yr)	Electricity Savings (\$/1st Yr)	GHG Emission Reduction (MT/Yr)	Capital Cost (\$)	Incentive Amount (\$)	Net Cost (\$)	Avg Annual Net Savings (\$/Yr)	NPV of Cumulative Net Savings (\$)
39,907	\$4,545	8	\$0	\$0	\$0	\$6,766	\$95,867

EEM-4: Modify 3W Water Scum Spray and Install VFDs

LTP currently uses about 1.0 MGD of tertiary treated recycled water (3W water), mostly for the primary clarifier scum spray system. The water spray system is designed to push the scum to a removal spot, which is not the most efficient method and wastes a lot of water. Staff has considered the option of re-designing and replacing the spray nozzles to change the flow and spray patterns.



Figure 1-6: Recycled Water (3W) Booster Pumps

It is recommended that LTP consider the installation of a tipping skimming trough across each of the primary clarifiers to allow the water flow to push the scum to the trough instead of the water spray. This would require significant engineering and construction expense, which are not estimated here.

The 3W water pumps may also be a good candidate for VFDs. Currently the four 75 horsepower (HP) 3W pumps cycle on/off in response to changes in system pressure. Generally there are two pumps running at any given time. VFDs on two units would allow a base pump without a VFD to run 100% along with a pump with a VFD. The energy savings associated with this EEM cannot be calculated with the information available at the time of the audit.

EEM-5: Reduce Air to Mixed Liquor and Primary Feed Channels

The mixed liquor channel leading to the secondary clarifiers and the channel feeding the primary clarifiers both have coarse bubble diffusers to keep the contents in suspension while flowing. This air comes from the variable speed aeration blowers. Reducing or eliminating the air would result in less blower energy to meet the overall demands.



Figure 1-7: Mixed Liquor Channel with Aeration

A visual inspection showed that the velocity in many parts of the channels is probably sufficient to keep material in suspension without the use of the air. LTP staff would need to manually shut off drop legs to the diffuser grids and watch for settling. At the same time, they can determine the difference in blower energy with some or most of the channel diffusers shut off. Note that the velocity in the channels would be the lowest during the lowest diurnal flow period. The velocity needs to be 1 foot per second (fps) or greater to ensure settling does not occur. A 5% reduction in aeration blower output would create a savings of 285,000 kWh per year, with an average annual net savings of over \$47,400 per year, and NPV of cumulative net savings of over \$672,000. This estimate is based on a 2013 summary data provided by LTP. Velocity in the channels was calculated to be 0.2 fps based on 20 MGD and a cross sectional area of 160 square feet. There may be a slope to the channels (which was not clear from the hydraulic profile) that could increase the velocity. Note that the channel bends and splits and the velocity was not consistent throughout the channel during the visual inspection. Though the mathematical velocity looks too low to support this recommendation, some experimentation with closing some or partially closing other channel air headers may enable an air reduction without allowing setting.

If the air to the channels could be choked down or shut off (and not cause settling in the channel), it is our professional judgment that approximately 5% to 10% of the aeration blower output could be saved. The cost savings is based on 5% reduction in current blower energy output.

Table 1-14: EEM-5 Reduce Air to Mixed Liquor and Primary Feed Channels
Summary

Electricity Savings (kWh/Yr)	Electricity Savings (\$/1st Yr)	GHG Emission Reduction (MT/Yr)	Capital Cost (\$)	Incentive Amount (\$)	Net Cost (\$)	Avg Annual Net Savings (\$/Yr)	NPV of Cumulative Net Savings (\$)
285,000	\$32,456	59	\$0	\$0	\$0	\$48,324	\$684,650

EEM-6: Run Idle Cummins Engines on Natural Gas to Generate Electricity

LTP typically operates one of four available Cummins generators, using mostly digester gas, to produce 1.1 MW of electricity and heat for the Digester Heat Return Supply (HRS) loop.



Figure 1-8: Overview of the CHP Facility

Currently the cost of producing electricity with the CHP using purchased natural gas is lower than purchasing electricity from PG&E. It is recommended that Santa Rosa move forward with the recommendation in the “Natural Gas Evaluation Technical Memorandum” (Brown and Caldwell, December 2013) to run one (and possibly two) of the idle generators on natural gas. That study estimates annual electrical savings of \$300,000 for one generator running off natural gas, and over \$700,000 per year for two generators running off natural gas. KJ did a review of the savings that would be achieved by running one engine on natural gas. The analysis showed an estimated average annual net savings of \$209,000 per year, with a NPV of cumulative net savings over ten years of over \$1.74 million. Since this recommendation had already been presented in a 2013 Brown and Caldwell study, these savings were **not** included in our overall savings estimate from this energy process audit.

It should be noted that a substantial upgrade to the CHP emissions scrubber system would be required for this recommendation to be viable. The costs of the capital improvement project were not included in the calculations shown below.

Table 1-15: EEM-6 Run Idle Cummins Engines on Natural Gas Summary

Electricity Savings (kWh/Yr)	Electricity Savings (\$/1st Yr)	GHG Emission Reduction (MT/Yr)	Capital Cost (\$)	Incentive Amount (\$)	Net Cost (\$)	Avg Annual Net Savings (\$/Yr)	NPV of Cumulative Net Savings (\$)
3,135,000	\$987,613	1,782	\$775,000	\$0	\$775,000	\$209,691	\$1,743,110

EEM-7: Optimize Return Activated Sludge (RAS)

Each of the five secondary clarifiers has its own RAS pumping station. The Mixed Liquor Suspended Solids (MLSS) to RAS ratio and the Statepoint model both indicate the RAS rate can be reduced. RAS optimization benefits include lower RAS pumping energy, improved selector performance, reduced sludge volume, increased single pass aeration detention time, and improved clarifier settling conditions. However, RAS optimization is limited by poor turndown on the existing RAS pumps, which have plugging issues in the clarifier RAS tubes when the RAS is turned down too low. This RAS restriction currently precludes the facility’s ability to optimize the RAS flow as recommended.



Figure 1-9: RAS Pumps Adjacent to the Clarifier

It was roughly and conservatively estimated that 30 HP could be realized through RAS optimization. This would result in an average annual net savings of 186,000 kWh per year, approximately \$31,000 per year, with a NPV of cumulative net savings of over \$447,000. LTP staff is working to measure actual savings.

Table 1-16: EEM-7 Optimize Return Activated Sludge Summary

Electricity Savings (kWh/Yr)	Electricity Savings (\$/1st Yr)	GHG Emission Reduction (MT/Yr)	Capital Cost (\$)	Incentive Amount (\$)	Net Cost (\$)	Avg Annual Net Savings (\$/Yr)	NPV of Cumulative Net Savings (\$)
186,246	\$21,210	38	\$0	\$0	\$0	\$31,579	\$447,416

EEM-8: Stagger Digester Mixing Pumps During Peak Period

LTP has four 40 HP digester mixing pumps. It is recommended that Santa Rosa turn off the digester mixers for at least 2.5 hours during the peak period, staggering the shut-off during the period so that not all the pumps are turned off at the same time. This change is estimated to save over \$18,000 per year, nearly 109,000 kWh, with a NPV of cumulative net savings of over \$261,000. It is recommended that LTP staff check gas quality and production and watch digester stability and control numbers. If there is no degradation of digester performance, the duration of pump shut off could be increased.



Figure 1-10: Digester Gas Mixing Pumps

Table 1-17: EEM-8 Stagger Digester Mixing Pumps During Peak Period Summary

Electricity Savings (kWh/Yr)	Electricity Savings (\$/1st Yr)	GHG Emission Reduction (MT/Yr)	Capital Cost (\$)	Incentive Amount (\$)	Net Cost (\$)	Avg Annual Net Savings (\$/Yr)	NPV of Cumulative Net Savings (\$)
108,916	\$12,403	22	\$0	\$0	\$0	\$18,467	\$261,647

EEM-9: Install VFDs on Aerated Grit System

LTP currently runs two aerated grit systems seven months and one for five months out of the year. Each grit system is aerated by a 10 HP blower. At night when the flow drops, the plant gets much less grit due to lower sewer velocity and less inorganic loading. However, the blowers run at a constant speed. The addition of a VFD could allow turndown during the low flow periods.



Figure 1-11: Grit Tank with Aeration

As currently operated, it costs approximately \$10,000 per year to run the grit blowers. This EEM would save approximately \$3,000 per year, or 18,600 kWh, with a NPV of cumulative net savings of over \$42,400. VFDs could result in the equivalent of shedding three HP for the year. The capital costs and energy savings are based on upgrading only two of the aerated grit blowers with VFDs.

Table 1-18: EEM-9 Install VFDs on Aerated Grit System Summary

Electricity Savings (kWh/Yr)	Electricity Savings (\$/1st Yr)	GHG Emission Reduction (MT/Yr)	Capital Cost (\$)	Incentive Amount (\$)	Net Cost (\$)	Avg Annual Net Savings (\$/Yr)	NPV of Cumulative Net Savings (\$)
19,500	\$2,879	4	\$3,000	\$1,000	\$2,000	\$1,779	\$40,654

EEM-10: Implement Building and Lighting EEMs

In June 2012 BASE Energy, Inc. prepared an Integrated Energy Audit Report No. BASE-PGE-11-05 for LTP building and lighting systems. KJ did not do a review or verify these recommendations but advises Santa Rosa to consider cost-effective EEMs that have not already been implemented.

1.5 Detailed Descriptions of Recommended Process Improvements

PIs differ from the EEMs in that PIs are not recommendations that would necessarily result in electrical savings. They are added to the technical memo to allow documentation of recommendations that may be beneficial to plant personnel or performance.

PI-1: Reroute Filter Backwash Water

KJ recommended rerouting the filter backwash water to the head of the plant so that the anthracite lost in the filter backwash is removed by the grit system and does not settle in the primary influent channel.

LTP management liked this idea of this PI and took it under serious consideration. However, it was reluctantly rejected. The backwash waste basin is shared with the belt press filtrate. Separating the two streams would require rerouting the filtrate either to the headworks or the flow equalization basin and would result in slug loading on the aeration system. Introducing soluble BOD to the primary system is also not desirable because it does not get removed in the primary system and therefore reduces capacity.

PI-2: Enhance SCADA Screens

It is recommended that a “power screen” be added to SCADA system. The power screen would summarize current power use, percent change from previous day, percent of CHP, etc. Including a read-out showing the highest electrical peak for the month (to date) would be a useful tool for making equipment operation decisions. This would provide operations with real-time feedback.

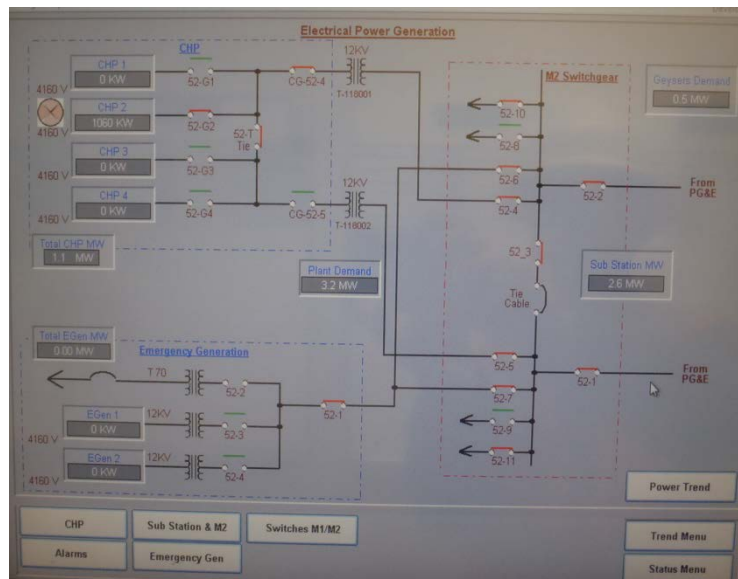

Figure 1-12: SCADA Electrical Power Generation Screen

Other SCADA pages could include cost of energy and chemicals where beneficial to allow LTP operators to see the effect and cost of process changes they initiate through SCADA.

PI-3: Increase Belt Press Solids Concentration

The sludge concentration leaving the belt presses averages 14.8%. LTP contracts with a trucking company to relocate the sludge from the Belt Press Building to the biosolids composting site located across the street on Llano Road. Three to four trucks per day, six days per week is the average hauling frequency. Increasing the sludge concentration to 18% would reduce the number of trucks by almost 90 trucks per year (9% reduction). The associated energy savings is described in TM #2 – Biosolids Compost Audit. An increase in belt press solids also increases the capacity of the in vessel composting and provides labor, truck wear, and fuel savings.

Various potential methods of increasing the solids concentration were discussed with LTP staff during the workshop. Most had been tried without success, but one possible idea is to change the way the polymer is selected. LTP currently requires the polymer be capable of producing 15% sludge. Changing the requirement to 18% might result in a different polymer and better sludge. However, the cost per dry ton of the new and old polymer would need to be analyzed.

There also may be a potential to replace the weave on one of the belt systems to allow for a higher dewatering rate and/or improved dewatering capabilities.



Figure 1-13: Belt Press Equipment

PI-4: Monitor Primary Sludge pH

It is recommended that primary sludge pH monitoring be instituted as a means of checking for sludge septicity. Septicity in the primary sludge increases energy use and cost of the aeration and blower systems. In addition, it may create organic acids that can lead to filament growth. It is recommended that the current sampling method and frequency be evaluated to ensure the daily numbers are representative.

PI-5: Upgrade Digester Mixing

It is recommended that LTP revisit and implement the upgrades to the digester mixing system documented in the Technical Memorandum: Laguna Subregional Water Reclamation Facility, Digester Mixing System (Kennedy/Jenks, 14 March 2003). While an upgrade to the mixing system may or may not be a direct energy savings measure, it would have operational and cost savings benefits such as improved mixing, the potential from increased gas production, and the ability to put fats, oils and grease (FOG) and food waste into the digesters.

Optimizing the digester mixing system to a more efficient and higher rate system has benefits that stand on their own merit as mentioned above. As discussed previously in EEM-8, the toggling of the digester mixing pumps off for 2.5 hours each during the peak electrical period has merit of its own due to the energy savings potential. It is recommended the toggling be trialed with the current mixing system and again with a new mixing system, should the current mixing system be upgraded.

PI-6: Reduce Sludge Yield

In 2013 LTP secondary system operated with an annual average sludge yield ratio of 0.9. Sludge yield is the mass of waste sludge produced per pound of Biological Oxygen Demand (BOD) to the aeration basin:

$$\text{Sludge Yield (ratio)} = \text{Pounds of Waste Sludge Generated} / \text{Pound of BOD Load to Aeration}$$

A lower sludge yield would indicate that microbes had converted more of the secondary solids (created when they consume the dissolved BOD) into carbon dioxide and digester gas, resulting in less secondary sludge. Text book numbers for sludge yield for a plant process similar to LTP are between 0.6 and 0.7. Reducing the sludge yield from the current 0.9 to 0.7 would result in a 20% reduction in the secondary sludge.

A lower sludge yield results in lower waste pumping, lower RAS pumping, reduced number of gravity belt thickeners, possibly lower polymer use, and increased digester capacity.

Sludge yield could potentially be reduced by increasing aeration of the MLSS and/or by increasing treatment detention time. It is recommended that staff experiment with increasing the MLSS to see the effect on sludge yield and how it affects treatment performance. Cost savings cannot be estimated without a change of operation and a determination of actual changes in sludge yield and the associated pumping.

Trend charting historical MLSS/Solids Retention time versus Sludge Yield may illustrate whether small changes to the MLSS would result in a reduced sludge yield. This could be done prior to any field testing.

December 31, 2014

Technical Memorandum #2

To: Mike Prinz, Zachary Kay, and Colin Close, City of Santa Rosa

From: Charles Wright, P.E. – Compost Audit Deputy Lead
Mark Cullington, P.E. - Compost Audit Lead
Mike Joyce, P.E. - Reviewer
Julia Lund PE, LEED AP - Deputy Project Manager
Alan Zelenka - Project Manager

Subject: Task 1.2 – Compost Facility Energy Audit
Santa Rosa Energy Optimization Plan (EOP) – Phase 1
K/J Project: 1368024*01

An energy audit was conducted by Kennedy/Jenks (KJ) at the Laguna Subregional Compost Facility (Compost Facility) on April 10, 2014. The purpose of the audit was to identify and recommend cost-effective Energy Efficiency Measures (EEMs) for implementation by the Compost Facility staff to save energy and reduce operating costs.

2.1 Recommendations

Four EEMs were identified during the audit. After the analysis was conducted, two EEMs were determined to be cost-effective and are recommended for implementation and are listed in Table 2-1 below. Cost-effectiveness is defined as an EEM that had a positive Net Present Value (NPV) from savings over the life of the EEM.

Table 2-1: List of Recommended Energy Efficiency Measures

EEM #	Title	Average Annual Net Savings (\$/Yr)
1	Modify Exhaust Fan Operation	\$13,000
3	Install Solar PV (PPA)	\$41,400

As shown in Table 2-2, implementing the two recommended EEMs would result in about \$54,400 in average annual net savings, a NPV of \$797,600 in savings over the 20 to 30 year lives of the EEMs, and a reduction in GHG emissions of over 421 metric tons of CO₂ per year. The estimated electricity savings and generation of 1,911,700 kWh per year, which is greater than the Compost Facility energy use in 2013 (890,000 kWh).

Table 2-2: Summary of Recommended Energy Efficiency Measure Savings

Electricity Savings (kWh/Yr)	Electricity Savings (\$/1st Yr)	GHG Emission Reduction (MT/Yr)	Capital Cost (\$)	Incentive Amount (\$)	Net Cost (\$)	Avg Annual Net Savings (\$/Yr)	NPV of Cumulative Net Savings (\$)
1,911,700	\$219,500	421	\$50,000	\$0	\$50,000	\$54,400	\$797,600

In addition, it is recommended that Santa Rosa consider implementing the Compost Facility-specific lighting recommendations provided in the Integrated Energy Audit (BASE Energy Inc, 2012), which is described in TM #1 – LTP Process Energy Audit.

Typically, the recommended priority order for implementation is based on the Return On Investment (ROI) for each recommended EEM. ROI is calculated using the Excel IRR function, but cannot be calculated if the capital cost is zero (a “NC” represents “not calculable”). Essentially, the ROI is infinite without capital costs; so EEMs with zero capital cost are therefore ranked based on the amount of NPV of cumulative net savings it brings to the City. Therefore the priority order is based on average annual net savings, as listed in Table 2-3.

Table 2-3: Priority Implementation Order

Rank Order	EEM#	Title	ROI (%) ¹	NPV of Life of Savings (\$)
1	1	Modify Exhaust Fan Operation	NC	\$183,500
2	3	Install Solar PV (PPA)	17%	\$614,400

¹ NC = Not calculable because the ROI for projects with zero capital cost do not calculate using the Excel IRR function. With zero capital cost the ROI is essentially infinite.

Although the City’s current composting system provides for an effective means of producing a quality Class A biosolids compost product and has done so for over 15 years, there are alternative technologies available to the City that would potentially save energy, reduce emissions, and significantly reduce overall operations and maintenance costs. Alternative composting technologies could include covered aerated static piles, aerated static piles, and in-vessel systems. KJ suggests the City investigate alternatives in the near future. Evaluating these alternatives was beyond the scope of work for this energy audit which focused on the existing system.

2.2 Background

Facility Description

The Compost Facility converts anaerobically digested biosolids (approximately 8,000 wet tons in 2013) to a high quality Class A biosolids compost product, the majority of which is sold to local landscaping companies. Lesser amounts are sold to individuals or donated to local community gardens and schools. The facility is an aerated, agitated in-vessel composting system that uses four compost turners (agitators) that turn the material in the bins each day. Following construction of the facility in 1995, Compost Facility staff has made adjustments to increase process throughput and minimize operational costs. Most recently these efforts have included adjusting the compost recipe

in terms of the amount of biosolids used and closely monitoring the moisture content of the material as it moves through the composting process.



Figure 2-1: Panorama View of the Laguna Subregional Compost Facility

Energy Use and Cost

As part of the data collection prior to the onsite audit, Santa Rosa provided baseline energy usage for its Subregional system, including the biosolids Compost Facility. The baseline provides a snapshot of how much energy is currently used at the existing Compost Facility to allow for comparison to what impacts the various audit recommendations will have. The baseline energy profile for the Compost Facility includes electricity use, since natural gas usage is negligible.

KJ worked with Santa Rosa staff to collect the necessary data to create the baseline in a spreadsheet model entitled "Santa Rosa Energy Baseline." Baseline data were developed using daily operating data from the Santa Rosa SCADA system and monthly billing data from PG&E for the period of January 2012 through December 2013.

For the Compost Facility, the electricity baseline was broken down into Compost and Miscellaneous Storage Facility categories, which respectively include data from SCADA and PG&E. The baseline is summarized in Table 2-4.

Table 2-4: Baseline Electricity Usage for Compost Facility

Category	Baseline Annual Electricity Use (kWh/Yr)	Baseline Annual Electricity Cost (\$/Yr)
Compost ¹	890,000	\$61,000
Miscellaneous Storage Facility ²	5,600	\$1,200
Total Electricity Used for Biosolids Composting	896,000	\$62,000

¹ Data are from Santa Rosa SCADA system from January 2013 to December 2013. Data from 2012 were not representative of typical operations.

² Average annual PG&E data from January 2012 to December 2013.

As shown in Figure 2-2, the biosolids Compost Facility uses a relatively small percentage of the total electricity of the Subregional system.

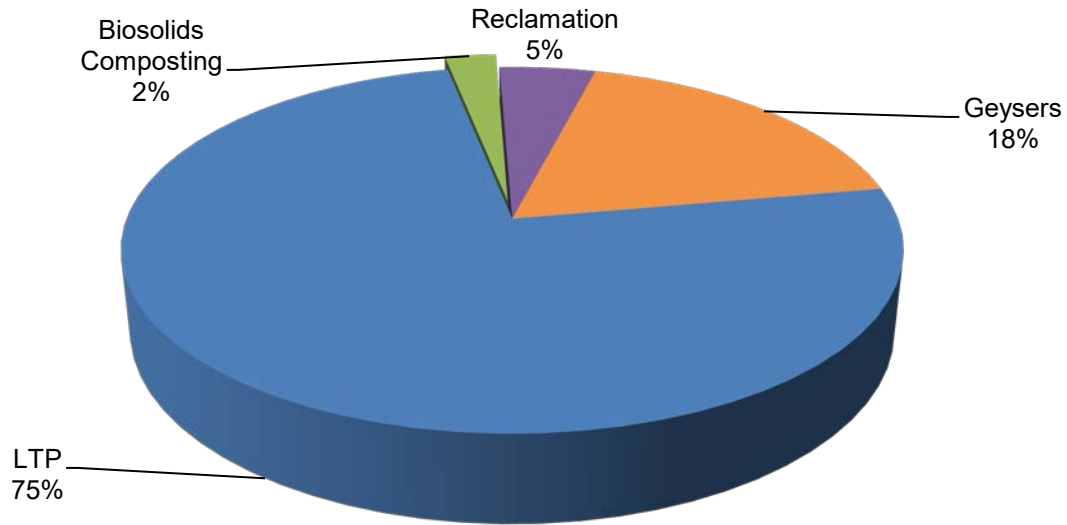

Figure 2-2: Annual Electricity Usage for Subregional System by Category

2.3 Overview of Audit Methodology

The energy audit for the Compost Facility included initial data collection and review, an on-site field audit and an evaluation of potential EEMs.

Initial background data collection and review included the following documents:

1. Biosolids Management Strategic Plan, January 2014.
2. Laguna Subregional Water Reclamation Facility, Draft Final Biosolids Program, Phase II, June 2003.
3. Annual Biosolids Reports (2010-2013).
4. Biosolids Compost Audit (A document prepared by Compost Facility staff in response to initial background questions posed by KJ).

After completing the initial data collection and review, a field audit was conducted on April 10, 2014. Participants included all 8 staff members from the Compost Facility (Zachary Kay, Al Myers, Christina Holton, Ed Garcia, Tim Turner, Mike Endercott, Jim Swanson, and Paul Sheridan). KJ participants included Mark Cullington and Charles Wright. A project team discussion was held with all Compost Facility staff to provide a thorough overview of composting operations and Santa Rosa's biosolids beneficial reuse program. An initial list of facility challenges and opportunities for energy and/or process optimizations was developed during the meeting.

A tour of the Compost Facility followed the team meeting. The objective of the tour was to gain a better understanding of the facility and to identify all of the existing processes and equipment that use energy and identify potential areas for improvement.

The field audit concluded with a final team meeting. Information gathered during the initial team meeting and subsequent facility tour was reviewed for accuracy. The initial list of facility challenges

and opportunities for improvements was refined, and a number of potential EEMs were vetted by Compost Facility staff for their initial reaction.

Using information gathered during the initial data review and subsequent field audit, EEMs were identified and evaluated for cost-effectiveness. This analysis provides a summary of these EEMs and the potential cost savings that could be realized. Cost calculation tables were developed for all EEMs and are provided as electronic attachments.

2.4 Detailed Descriptions of Recommended Energy Efficiency Measures

The following section describes two EEMs that were identified during the audit as being cost-effective and are thus recommended for implementation. All calculated values are based on rough order of magnitude estimates and what is believed to be the best available data. The cost estimates are based on the Association for the Advancement of Cost Engineering International (AACEI) standards for cost estimating accuracy of +50% and -30%.

EEM-1: Modify Exhaust Fan Operation

Five, 100 horsepower (HP) variable speed fans are used to draw air from inside the active composting area and exhaust it through a 50,000 square foot biofilter. The system was provided to eliminate fugitive odors and to maintain acceptable working conditions inside the Compost Facility building in terms of air quality. Four of the five fans are original having been installed in 1995. One fan broke down and was replaced in 2001. While the existing fans could be replaced by newer more efficient units, it is very unlikely that doing so would be cost effective. As a result, the objective of EEM-1 is to reduce energy consumption by modifying operation of the Compost Facility building exhaust fans instead of replacing them.



Figure 2-3: Compost Building Exhaust Fans

The existing fans have variable frequency drives (VFDs) that allow fan speed to be adjusted to provide appropriate ventilation rates. Compost Facility staff has developed a table of speed settings that correspond to fan speed (as shown in Figure 2-4). This does not directly correlate with motor speed because belt drives connect the nominal 1,800 revolutions per minute (rpm) motors to the fans themselves. Facility staff currently operates the fans at speed setting-6 (955 rpm) during working hours. Fan speed is reduced to setting-4 (640 rpm) during non-working hours (evenings and weekends). The range of speed settings (4 to 6) is the maximum possible according to Compost Facility staff and was developed based on recommendations of the manufacturers of the fan and the motor.

SPEED #	NOMINAL FAN RPM
1	160
2	320
3	480
4	640
5	800
6	955
7	1105

NOTE: MAX FACTORY SPEC FOR FAN IS 1250 RPM

Figure 2-4: Exhaust Fan Speed Setting Chart

Although the exhaust fans operate at reduced speeds during non-working hours, this EEM would further reduce energy use by turning fans off during non-working hours. To determine the number of fans that might be turned off and still maintain appropriate ventilation rates, the following should be considered:

- National Fire Protection Association (NFPA) 820 Standards for Fire Protection of Wastewater Treatment and Collection Facilities. These standards state that for enclosed compost facility to be considered “unclassified” they must be ventilated at no less than six air changes per hour.
- Fugitive odors. Ventilation must be adequate to keep odors from escaping the Compost Facility building.

The existing system was designed to provide twelve air changes per hour during working hours. The fans are rated at 32,000 standard cubic feet per minute (scfm) each, which Compost Facility staff believe can be achieved by running the fans at speed setting-6 (955 rpm). If correct, and assuming a total ventilated building volume of 755,000 cubic feet, the current practice of running all fans at speed setting-6 should slightly exceed the design air change value.

Based on standard performance curves for centrifugal fans, reducing fan speed from setting-6 (955 rpm) to setting-4 (640 rpm) should be expected to result in an air flow of about 20,000 scfm per fan. In order to provide six air changes per hour (minimum rate needed for the building to be considered an “unclassified” space), four fans running at this reduced speed would be needed. Thus, only one fan could be potentially turned off during non-working hours and energy savings were calculated on this basis. A summary of the results of the financial analysis for EEM-1 is provided in Table 2-5.

Table 2-5: EEM-1 Modify Exhaust Fan Operation Summary

Electricity Savings (kWh/Yr)	Demand Savings (kW)	GHG Emission Reduction (MT/Yr)	Capital Cost (\$)	Incentive Amount (\$)	Net Cost (\$)	Avg Annual Net Savings (\$/Yr)	NPV of Avg Annual Net Savings (\$)
81,100	--	17	\$0	\$0	\$0	\$13,000	\$183,500

Assumptions:

- Calculations based on turning one fan off during non-working hours.
- Fan power draw: speed setting-6 = 80 HP/fan, speed setting-4 = 25 HP/fan.
- Fan flow rates: speed setting-6 = 32,000 scfm/fan, speed setting 4 = 21,000 scfm/fan
- Composting season is eight months/year. Other months exhaust fans are turned off.
- Net present value calculation is based on a 20 year time period.

Prior to implementing this EEM, KJ recommends that Compost Facility staff measure and confirm ventilation flow rates to ensure that the target air changes are being achieved. Two factors lead to this recommendation. The first is the relatively high level of ammonia in the air inside the compost building noticed during the site audit. While KJ understands that Santa Rosa staff has recently initiated air quality monitoring for ammonia, high ammonia level would be indicative of airflows less than 12 changes per hour. The second factor is lower than anticipated energy consumption by the Compost Facility. As is explained in later sections of this analysis (EEM-4), one explanation for this could be that the fans are not achieving their design flow rates resulting in less energy use than would occur if they were meeting design requirements.

Ports in the existing air piping used to convey air to the biofilters can be used to measure total air flow with pitot tubes. This should be done with the fans running both at full and reduced speeds to determine how many fans could potentially be turned off and appropriate minimum operating speeds. In addition, power use should also be measured under the various operating scenarios. Doing so may show that running fewer fans at full speed may actually be more efficient than running the fans at lower speeds.

Additional items that should be considered prior to the permanent implementation of this EEM is the extent of existing fan corrosion, and the impact operational changes may have on increasing rates of corrosion on interior building surfaces. Reducing the amount of ventilation during non-working hours may increase moisture, temperature, and ammonia levels inside the building. Because this may cause corrosion problems, staff should initially monitor conditions inside the building after first implementing changes in fan operation.

EEM-3: Install Photovoltaic Panels

The Compost Facility has approximately 3.6 acres north of the biofilters that could be made available for installation of solar photovoltaic (PV) panels. However, this area would not be available if endangered species (e.g., California Tiger Salamander) are present and a thorough investigation should be completed prior to moving ahead with this alternative. While the Compost Facility building has a significant amount of roof space, a prior investigation by Santa Rosa determined that it cannot support the weight and wind loads that would be created by the installation of PV panels. However, the roof structure is in the process of being evaluated for possible replacement the design of which could consider the installation of PV panels on the roof.

Another option not evaluated in this report that may warrant additional investigation, would be construction of a floating photovoltaic power system. Storage ponds adjacent to the Compost Facility could potentially be used for this purpose.

On average, solar panels can be installed to achieve approximately one kilowatt (kW) of electricity per 100 square feet of useable space when placed flat. When tilted, the kW installed per 100 square foot is somewhat less as the panels need to be placed apart so not to cast shadows on one another; however, the energy produced is greater when tilted. The estimated project size for the 3.6 acre area is listed in Table 2-6.

Table 2-6: Dimensions of Potential Solar PV Location at Composting Facility

Location	Approximate Area (square feet)	Assumed Technology	Estimated Size (kW)
Area north of biofilters	157,000	Fixed tilt at latitude	1,490

In order to determine kWh production, the electricity production for a 100 kW PV installation at various locations was calculated using the PVWatts tool developed by the researchers at the National Renewable Energy Laboratory (NREL): <http://www.nrel.gov/redc/pvwatts/grid.html>. The PVWatts calculator works by creating performance simulations that provide estimated monthly and annual energy production in kilowatts and energy value. It uses meteorological year weather data for the selected location and determines the solar radiation. Solar radiation is then converted and annual AC energy production is calculated (in kilowatt-hours per year per installed kilowatt). Based on PVWatts calculations, the annual energy production from a 100 kW PV installation is shown in Table 2-7.

Table 2-7: PVWatts Estimated Production per 100 kW System

Tilt	First-Year Energy Production (kWh produced per 100 kW installed) ¹
Open (Ground) Mount	
Fixed at 0 degrees (Flat)	118,000
Fixed Tilt at Latitude	132,000

¹ Includes energy production during the first year after installation. A solar PV system would lose efficiency every year at an approximate rate of 0.50% per year.

As shown in Table 2-8, a 1,490 kW fixed tilt PV project (ground mount) could produce an average of 1,830,600 kWh per year. Although this is greater than the baseline energy use of the Compost Facility, Santa Rosa could take advantage of California's Virtual Net Metering (VNM) incentive,

which allows local governments and special districts to install renewable generation of up to five MW at one location within its geographic boundary, and to generate credits that can be used to offset the generation charges at one or more other locations within the same geographic boundary.

Table 2-8: Projected Average Annual Energy and GHG Reduction

Location	Total Size (kW)	Average Annual kWh Produced (kWh/Yr) ¹	% of Compost Facility Baseline ²	Average Annual Metric Tons of CO ₂ Reduced
Area north of biofilters	1,490	1,830,600	204%	400

¹ Average annual production over 30 years. Assumes an annual PV degradation impact and loss of efficiency of approximately 0.50% per year.

² Average energy use at the Compost Facility of 896,000 kWh per year in 2013.

Santa Rosa could pursue a solar PV project through two different purchase structures options:

- **Own and Operate:** Santa Rosa would purchase a solar PV system using its capital, install the system on its property, and use Santa Rosa staff to operate the system.
- **Power Purchase Agreement (PPA):** A third party would finance, own and operate the solar PV system, and Santa Rosa would purchase the power generated from the third party. This could be an advantage for Santa Rosa because of no upfront capital costs and the availability of tax credits to a third party (which could be rolled into the pricing for Santa Rosa).

For an Own and Operate structure, prices vary based upon site conditions and system design (ground mounds, trackers, roof penetrations, etc.) and financing structure. According to Go Solar California, as of May 2014 the average cost of solar PV projects greater than 500 kW installed at government facilities in Sonoma County was approximately \$3.95 per Watt (California Energy Commission & California Public Utilities Commission, <http://www.californiasolarstatistics.ca.gov/>).

A previously available incentive for solar PV projects in Northern California was the California Solar Initiative (CSI), which offers rebates to customers in California's investor-owned utility territories. PG&E has sufficient solar PV projects in the queue to use up its allocation and therefore is not offering any CSI incentives at this time; however, Santa Rosa should track the program to be informed if it gets extended by the legislature and the CPUC. Additional information can be found at: http://www.cpuc.ca.gov/PUC/energy/Solar/CSI_General_Market_Program.htm

For a PPA structure, current rates may range from approximately \$0.09/kWh to \$0.12/kWh, depending upon the provider, annual escalator, and other negotiated terms.

Based on an installed cost of \$3.95 per Watt (not including the CSI incentive) and a PPA cost of \$0.10/kWh, a summary of the results of the financial analysis for a 1.49 MW solar PV system is provided in Table 2-9.

Table 2-9: EEM-4 Photovoltaic Panels Summary

Ownership Structure	Average Electricity Produced (kWh/Yr)	Demand Savings (kW)	GHG Emission Reduction (MT/Yr)	Capital Cost (\$)	Incentive Amount (\$)	Net Cost (\$)	Avg Annual Net Savings (\$/Yr)	NPV of Avg Annual Net Savings ¹ (\$)
a.) Own & Operate	1,830,600	--	400	\$5.9M	\$0	\$5.9M	-\$52,000 ²	-\$1.478M ²
b.) PPA				\$0.05M	\$0	\$0.05M	\$41,400	\$0.614M

¹ NPV is based on a 30 year period.

² Negative savings in red equals a cost to Santa Rosa.

2.5 Detailed Descriptions of Energy Efficiency Measures Not Recommended

The following section describes EEMs that were identified during the audit but not found to be cost-effective and are thus not recommended for implementation.

EEM-2: Change Compost Screen Location

The objective of EEM-2 was to reduce the fuel consumption and labor associated with moving compost to the screening equipment. As shown in Figure 2-5, material from the agitated bins is conveyed from inside the Compost Facility building and dropped near the center of the covered area used to store compost overs, yard debris, and bulking material. A front loader with five cubic yard bucket moves the material from this point to the screening equipment (shown in the background of Figure 2-5). This EEM would place the screening equipment directly beneath the conveyor discharge chute, which would reduce material handling costs associated with use of the front-end loader.



Figure 2-5: Screening Equipment Location Relative to Conveyor

During the audit, Compost Facility staff stated the screening equipment had at one time been located directly beneath the conveyor. It was moved after experiencing problems with synchronizing operation of the two pieces of equipment. Additional discussion suggested that staff had been able to successfully adjust speed settings to synchronize operation but that this information may not have been conveyed during changes in staffing at the facility.

A summary of the results of the financial analysis for EEM-2 is provided in Table 2-10.

Table 2-10: EEM-2 Change Screen Location Summary

Diesel Savings (gal/Yr)	GHG Emission Reduction (MT/Yr)	Capital Cost (\$)	Incentive Amount (\$)	Net Cost (\$)	Avg Annual Net Savings (\$/Yr)	NPV of Avg Annual Net Savings (\$)
306	3	\$0	\$0	\$0	\$14,500	\$208,500

Assumptions:

- Front end loader capacity = 5 yd³
- Compost production rate = 350 yd³/day
- Composting season = 8 months
- Time required per trip between conveyor and screen = 1 minute.
- Front end loader fuel consumption = 1.5 gallons/hour
- Fuel cost = \$3.50/gallon
- Labor savings equivalent to 0.1 FTE.
- NPV is based on a 20 year time period.

After further evaluation of relocating the screener under the conveyor discharge chute it has been determined by the Compost Facility staff that EEM-2 will not be practical due to the configuration of the screener. Relocation will actually cause additional workload on the loader and the need to install push walls for the fines and overs coming off the screener. In addition, the plastics bin will be trapped between the conveyors and the overs pile making it very difficult, if not impossible, for the bin to be picked up by the hauling company. Therefore, this EEM is not recommended.

EEM-4: Reduce Moisture Content of Biosolids

Increasing the solids content of the biosolids could reduce the energy consumption and all other operating costs associated with the Compost Facility. Prior studies, including the 2014 Biosolids Management Strategic Plan (Strategic Plan), examined potential positive impacts to the facility if the moisture content of biosolids was reduced.

Biosolids received from the Laguna Wastewater Treatment Plant (LTP) range in solids concentration from 12% to 18% with a typical value of about 15%. As noted in prior studies, the solids content has a significant impact on composting and the time needed for the facility to process a given mass of biosolids. Two factors are directly related to this:

- As the percent solids decreases, to compost an equivalent amount of biosolids on a dry mass basis, the total wet mass must increase.
- Ratio of biosolids to green waste in the compost recipe must decrease as the biosolids become wetter (decreasing dryness and solids concentration). If not, the compost mixture can become too wet and heavy causing the agitators to operate more slowly. This leads to increased operating time and can prevent the material from being turned within a normal working day. Compost Facility staff also report that wear on the agitators increases and is

accompanied by a significant increase in the frequency of breakdowns and increase in maintenance costs.

Changes in the solids content of the biosolids has a compounding effect on the dry weight of biosolids that can be composted. In other words, as the moisture content in the biosolids increases, not only does the total mass increase but the amount that can be treated in each batch of compost decreases. This results in a rapid increase in the amount of composting needed to treat the same amount of biosolids on a dry mass basis.

The Strategic Plan identified several means of increasing solids content (e.g., operational changes, covered biosolids storage, and improved dewatering at the Plant). Cost savings that could be obtained by increasing the throughput of the Compost Facility (economy of scale) were then determined. An annual throughput goal of 12,000 wet tons of biosolids was identified as an optimum goal with an associated potential annual savings of about \$120,000. The Strategic Plan recommended this goal be met via operational changes rather than significant capital investment (e.g., covered storage). It suggested changing to a “just-in-time” model for delivering biosolids to the Compost Facility. The intent was to avoid accumulating biosolids in the Compost Facility’s uncovered biosolids pond storage area (Figure 2-6). Because it is uncovered, storing solids in the pond during years with normal precipitation has resulted in significant wetting of the material resulting in solids concentrations as low as 10% to 12%. Other changes requiring significant capital investment (e.g., constructing covered biosolids storage) were not recommended.



Figure 2-6: Composting Facility Pond Biosolids Storage Area

As noted, the Strategic Plan based its value for annual savings on composting 12,000 wet tons of biosolids each year. Actual operations since 2010 show an average of only 8,000 wet tons of biosolids composted per year. Compost Facility staff believe that achieving a 50% increase in the amount of biosolids composted each year is not likely. This conclusion is based on the following:

- Compost recipe would have to change significantly. The current recipe uses 12,000 wet pounds of biosolids per batch. The ratio of biosolids in the recipe has increased dramatically

over the years with staff reporting as little as 6,000 wet pounds of biosolids per batch was used during earlier years of operation. Staff invested a significant amount of time to fine tune the compost recipe and have unsuccessfully tried using as much as 14,000 pounds per batch. In order to achieve a 50% increase in the amount of biosolids composted each year, with no increase in the composting season (eight months out of the year), a total of 18,000 wet pounds of biosolids would have to be used in each compost batch. Compost Facility staff does not believe this is possible regardless of the solids concentration of the biosolids.

- Composting is more costly than land application. Diverting more biosolids to the Compost Facility would reduce the amount of solids available for land application. Because composting costs as much as five times more than land application of Class B biosolids, diverting biosolids to composting would increase overall operating costs of the beneficial use program.

Increasing the amount of biosolids treated each year does not appear feasible; therefore, this EEM assumes the facility will continue to compost biosolids at the current average rate of 8,000 wet tons per year. Cost and energy use benefits to the Compost Facility were instead based on the amount of time by which the composting season could be shortened if dryer biosolids were treated. Savings associated with a shortened operating season were then used to evaluate the cost-effectiveness of various alternatives that could be used to increase the solids content of the biosolids.

Because increasing the amount of biosolids treated each year is not likely, we assume the Compost Facility will continue to compost biosolids at the current average rate of 8,000 wet tons per year. To determine if any energy use and cost savings could be obtained at the Compost Facility we focused on the amount of time by which the composting season could be shortened if dryer biosolids were treated. We analyzed two options: 1) changing the dewatering process (EEM-4a), and 2) covering the biosolids storage area (EEM-4b). As shown below, neither option is likely to be cost-effective and is not recommended for implementation.

EEM-4a: Cover Biosolids Storage Area

During periods of the year when the Compost Facility's other storage facility (Alpha Farm) is full and land application has not yet started (typically in the late spring), biosolids production from LTP exceeds that which can be composted. Solids are then stored in the pond storage area of the Compost Facility. As previously noted, significant wetting of the uncovered biosolids can happen during years with normal precipitation, leading to solids concentrations as low as 10% to 12%. Covering the biosolids storage pond area would be one option to increase the overall average solids concentration of the biosolids being composted each year.

The Strategic Plan examined this as one potential alternative and estimated construction costs ranging from \$1 to \$3.4 million depending on the type of structure provided. The lower end of the cost range would be a less permanent structure such as a tent, whereas the higher end of the cost range would replicate something similar to the Alpha Farm storage building (Figure 2-7).



Figure 2-7: Alpha Farm Biosolids Storage Building

The financial analysis for this EEM was based on continuing to compost biosolids at a rate of 8,000 wet tons per year. Of this amount, it was assumed that 25% would typically be placed into the pond storage area. The solids concentration of the stored biosolids after being subjected to normal levels of precipitation was assumed to be 13%. Based on the facility's annual biosolids reports for 2010 through 2013, the solids concentration for all biosolids combined (both stored and not) was assumed to be 15%. With these assumptions, covering the biosolids storage pond could potentially increase overall solids concentration of all biosolids composted to about 15.8%. This coupled with an assumed increase to 13,000 pounds from the current 12,000 pounds of biosolids processed per batch of compost could decrease the composting season by one month resulting in both energy and labor savings. A summary of the financial analysis for the lower cost cover (\$1 million for a tent-like structure) is summarized in Table 2-11.

Table 2-11: EEM-4a Cover Biosolids Storage Area Summary

Electricity Savings (kWh/Yr)	Demand Savings (kW)	GHG Emission Reduction (MT/Yr)	Capital Cost (\$)	Incentive Amount (\$)	Net Cost (\$)	Avg Annual Net Savings (\$/Yr)	NPV of Avg Annual Net Savings (\$)
124,000	--	25	\$1.0M	\$0	\$1.0M	-\$15,000 ¹	-\$251,700 ¹

¹ Negative savings in red equals a cost to Santa Rosa.

Assumptions:

- Total biosolids composted = 8,000 wet tons per year.
- Biosolids typically placed into the pond storage area = 25%.
- Solids concentration of stored biosolids during a normal precipitation year if not covered = 13%.
- Current average solids concentration for all biosolids combined = 15%.
- Average solids concentration for all biosolids combined if stored solids were covered = 15.8%.
- Normal composting season = 8 months.
- Amount by which the composting season could be shorted with increase in biosolids dryness = 1 month
- Energy use during an average normal 8 month composting season estimated to be 1,000,000 kWh
- Labor savings were calculated assuming that 4 staff members are directly affected by operation of the facility. For example, the amount of labor that could be saved by closing the facility 1 month early would be equal to about 690 hours (4 staff x 1 month x year/12 months x 2080 hours/FTE).

Covering the storage pond is not a cost-effective alternative and is therefore not recommended. However, other considerations beyond the scope of this audit could move Santa Rosa toward approval of the project. For example, runoff from the storage pond and adjacent finished compost piles is most likely high in dissolved organic material with low ultraviolet light (UV) transmittance. Depending on rain fall and the relative amount of runoff compared to total plant flow, this organic material could negatively impact the performance of the Plant's UV disinfection system resulting in higher energy use than would otherwise be needed. Solids contained in the runoff from the site would also increase overall loading to LTP that could result in higher energy use. An additional benefit of covering the storage pond, not accounted for in this analysis, would be increased flexibility for land application. Currently, all solids placed in the storage pond must be composted because the high water content from rainfall makes transporting them for land application unreliable. If the storage pond were covered, the facility would have the option to land apply the stored solids.

Verify Electrical Use

The preceding analysis was based on the assumption that the Compost Facility consumes about 1,000,000 kWh of electrical energy during a normal eight month composting season. This value was based on de-rated values of name plate motor horsepower and operating times as reported by Compost Facility staff. However, a baseline analysis of 2013 energy use for the Subregional treatment facilities showed that total consumption for the year was only about 890,000 kWh. Although this value is reasonably close to the calculated value (11% difference) and the vast majority of energy is consumed during the composting season, the values are different enough to warrant closer evaluation.

One explanation for the difference in energy use values could be that the building exhaust fans are not meeting system design values for air flow. The exhaust system was originally designed based on the fans providing 12 air changes per hour for the enclosed composting area. However, based on the relatively high levels of ammonia present in the air during the site audit, the fans may not actually be achieving this value. Because energy use is directly related to air flow, electrical consumption would be less than should otherwise be expected.

Verify Ventilation Flow Rates

Compost Facility staff reported direct experience with the relationship between exhaust fan air flow and energy consumption having seen increased electrical use after rebuilding the facility's biofilter beds in 2009. Prior to this work, staff had noted that exhaust air flow was abnormally low because of plugged air laterals in the filter beds. After rebuilding the beds and replacing all the original wood chip media with lava rock air flows increased dramatically along with a noticeable increase in electrical use.

As with other EEM's evaluated, KJ recommends that Compost Facility staff measure and confirm ventilation flow rates to ensure that the target air changes are being achieved. Doing so may yield information that could also explain the relatively high levels of ammonia within the Compost Facility building. Lowering these levels could lead to improved working conditions for Compost Facility staff.

EEM-4b: Change Dewatering Process

As previously noted, biosolids received from LTP's dewatering process range in solids concentration from 12% to 18% with a typical value of about 15%. Changes in the dewatering process at the Plant could increase this value leading to energy and cost savings at the Compost Facility. An analysis of the energy and potential cost savings that could be achieved with dryer biosolids was done and the

results are summarized in Table 2-12. Alternatives for improving the dewatering process were not evaluated as part of this audit. As a result the capital cost for this EEM is shown as needing to be determined (TBD). However, the values shown for savings should be useful to staff in evaluating the cost-effectiveness of alternatives assuming they wish to consider changes to LTP's dewatering process.

Table 2-12: EEM-4b Change Dewatering Process Summary

Electricity Savings (kWh/Yr)	Demand Savings (kW)	GHG Emission Reduction (MT/Yr)	Capital Cost (\$)	Incentive Amount (\$)	Net Cost (\$)	Avg Annual Net Savings (\$/Yr)	NPV of Avg Annual Net Savings (\$)
280,000	--	60	TBD	TBD	TBD	\$149,000	\$2.1M

Assumptions:

- Total biosolids composted = 8,000 wet tons per year.
- Current average solids concentration = 15%.
- Solids content after dewatering improvements = 18%.
- Current compost recipe uses 12,000 pounds per batch. After dewatering improvements assumed use of 14,000 pounds per batch.
- Normal composting season = 8 months.
- Amount by which the composting season could be shorted with increase in biosolids dryness = 2.3 months
- Energy use during an average normal 8 month composting season estimated to be 1,000,000 kWh
- Labor savings were calculated assuming that 4 staff members are directly affected by operation of the facility. For example, the amount of labor that could be saved by closing the facility 2.3 months early would be equal to about 1,600 hours (4 staff x 2.3 month x year/12 months x 2,080 hours/FTE).

February 13, 2015

Technical Memorandum #3

To: Mike Prinz, Allen Balsler and Colin Close, City of Santa Rosa

From: Dawn Taffler, PE, LEED AP – Recycled Water System Audit Lead
Julia Lund, PE, LEED AP – Deputy Project Manager
Alan Zelenka – Kennedy/Jenks Project Manager

Subject: Task 1.3 - Recycled Water System Energy Audit
Energy Optimization Plan (EOP) – Phase 1
K/J Project: 1368024*01

An energy audit of the City of Santa Rosa (Santa Rosa) Recycled Water System was conducted by Kennedy/Jenks (KJ) on March 26, 2014. The audit included a workshop with Santa Rosa operations staff, followed by a short site tour. The purpose of the audit was to identify and recommend for implementation cost-effective energy efficiency measures (EEMs) by analyzing the treatment, storage and conveyance system of recycled water.

3.1 Recommendation

Six EEMs associated with treatment process, pump station and customer focused improvements were identified for the Recycled Water System during the audit. After the analysis was conducted, four EEMs were determined to be cost-effective, and are therefore recommended for implementation. Cost-effectiveness is defined as an EEM that had a positive Net Present Value (NPV) from cumulative savings over the life of the EEM. All four of the recommended EEMs could be implemented immediately or in the near term. The four EEMs that were recommended are listed in Table 3-1 and summary of each follows.

Table 3-1: List of Recommended Energy Efficiency Measures

EEM#	Title	Average Annual Net Savings (\$/Yr)
2	Replace Ultraviolet (UV) Disinfection	Included in TM #1 – Laguna Treatment Plant Process Energy Audit
3	Eliminate Pressure-Relief Bypass	\$1,200
5	Reduce Delivery Pressures	\$2,000
6	Optimize Time of Use Rates	\$10,200

EEM 2: Replace UV Disinfection – Reducing the UV system costs is part of a larger strategy to address disinfection at the Laguna Treatment Plant (LTP). Potential energy savings for replacing the system are evaluated in TM #1 – LTP Process Energy Audit, which estimates a capital cost of over \$12 million, an average annual net savings of approximately \$124,000, and a NPV of cumulative savings of over \$1.23 million.

EEM 3: Eliminate Pressure-Relief Bypass – Connecting a hydropneumatic tank at Todd Road Pump Station is estimated to have a \$36,000 capital cost, an average annual net savings of approximately \$1,200, and a NPV of cumulative savings of \$25,000.

EEM 5: Reduce Delivery Pressures – Targeting pump stations with high specific energy for pump replacement is estimated to have a \$18,000 capital cost, an average annual net savings of approximately \$2,000, and a NPV of cumulative savings of \$22,200.

EEM 6: Optimize Operations for Time of Use Rates – By optimizing the operations of five pumps with the highest electricity use for the time of use rates has an estimated capital cost of \$10,000, an average annual net savings of \$10,200, and a NPV of cumulative savings of \$146,900.

If the recommended EEMs (3, 5, and 6, but not 2 which is included in TM#1 – LTP Process Energy Audit) were implemented, Santa Rosa’s capital cost would be approximately \$64,000. It could reduce its operating costs of the Recycled Water System by an average of \$13,000 per year with a NPV of cumulative savings of approximately \$194,500. It should also be noted that if these pump stations were to be taken off Santa Rosa’s energy bill, then some of the strategies from EEM 3 and 6 would need to be reassessed.

Table 3-2: Summary of Recommended Energy Efficiency Measure Savings

Electricity Savings (kWh/Yr)	GHG Emission Reduction (MT/Yr)	Capital Cost (\$)	Incentive Amount (\$)	Net Cost (\$)	Avg Annual Net Savings (\$/Yr)	NPV of Cumulative Net Savings (\$)
28,030	6	\$64,000	\$0	\$64,000	\$12,950	\$194,479

The priority order for implementation by Santa Rosa is based on the Return-On-Investment (ROI) for each recommended EEM. The recommended implementation order is shown in Table 3-3.

Table 3-3: Priority Implementation Order

Order	EEM#	Title	ROI (%)
1	6	Optimize Operations for Time of Use Rates	82%
2	5	Reduce Delivery Pressures	16%
3	3	Eliminate Pressure-Relief Bypass	1.3%
4	2	Replace UV Disinfection	n/a

3.2 Background

System Description

The Recycled Water System is defined by the infrastructure used to convey recycled water from LTP to irrigation customers in Santa Rosa and Rohnert Park and the Geysers Steamfield. Two thirds of the recycled water produced at LTP is conveyed directly to the Geysers Steamfield year-round. The remaining recycled water is conveyed through a complex system of ponds and pump stations for irrigation, urban usage (primarily in the summer) and discharge when needed. An overview of the Recycled Water System conveyance facilities is provided in Figure 3-1.

Santa Rosa's recycled water storage ponds provide a combined capacity of approximately 6 billion gallons. Attachment A includes a map illustrating the storage pond locations. Santa Rosa manages the recycled water system to meet recycled water demands and minimize discharge of recycled water to the environment. Tertiary disinfected recycled water produced at LTP meets California Code of Regulations for Title 22 disinfected tertiary recycled water (Attachment B).

Currently, the Delta Pond is the primary discharge location for the Recycled Water System, though there has been no substantial discharge within the last three years. Discharge is also permitted at Meadow Lane Pond and can directly discharge at LTP. The last discharge from Meadow Lane Pond was during the 2006 flood.

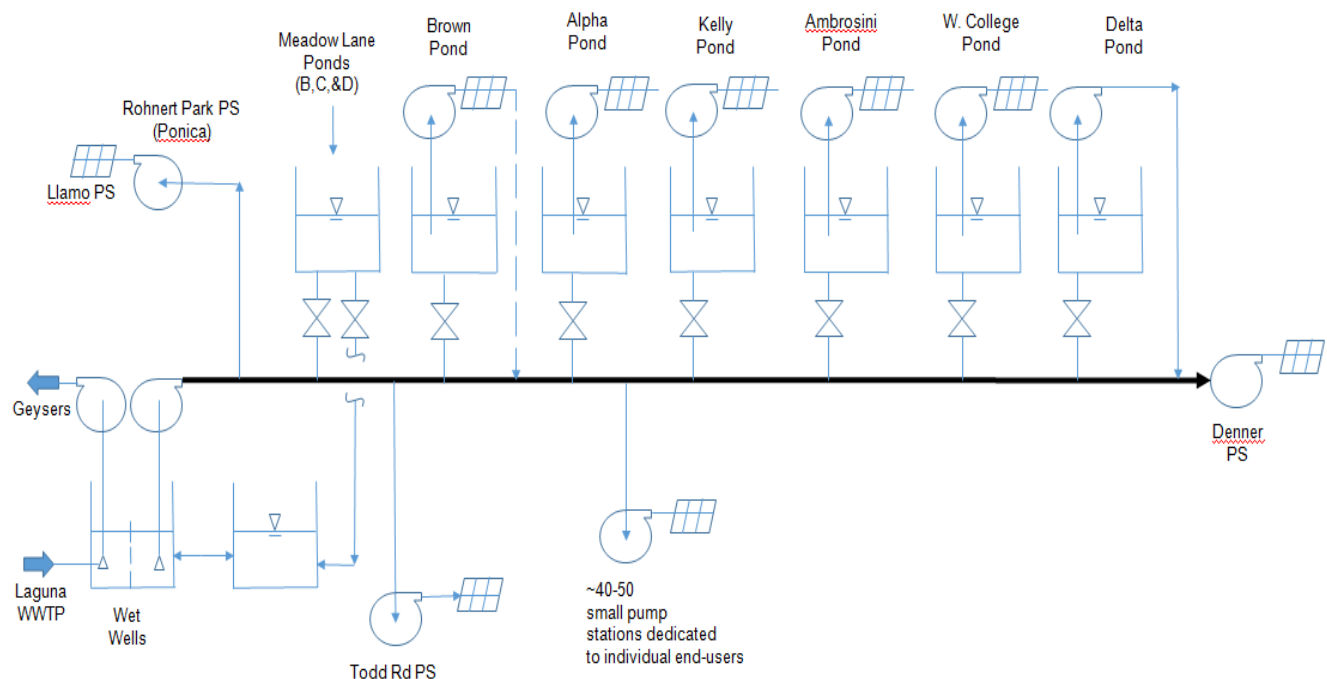

Figure 3-1: Overview of Santa Rosa Recycled Water System Major Conveyance Facilities

As shown in Figure 3-1, major recycled water pump stations (PS) including: Llano (Geysers system), Rohnert Park, Meadow Lane Ponds, Brown Pond, Alpha Pond, Kelly Pond, Ambrosini Pond, West College Pond, Delta Pond, Denver, and Todd Road; pump recycled water from storage ponds or directly from the conveyance trunk line for reuse. In addition, 40 to 50 other small pump stations are used to distribute recycled water to individual end users.

Santa Rosa has implemented several energy saving improvements for existing pump stations, including installation of variable frequency drives (VFDs), electronic valves (EVs), supervisory control data acquisition (SCADAs) and other features to improve the Recycled Water System's efficiency in the last few years. Attachment C lists pump stations improvements implemented as of April 2014. Santa Rosa also works directly with customers to operate the system at a higher efficiency by educating and encouraging farmers to irrigate at night, which saves water and energy. Santa Rosa is willing to further investigate operational energy efficiency improvements to decrease costs. This type of proactive approach will pay dividends to rate-payers for years to come.

Energy Use and Cost

As part of the data collection effort prior to the onsite energy audits, Santa Rosa provided baseline energy usage for its Subregional System, including the Recycled Water System. The baseline energy usage provides a snapshot of how much energy is currently used at the existing Recycled Water System to allow for comparison to what impacts the various audit recommendations will have. The baseline energy profile for the Recycled Water System only includes electricity use, since natural gas usage is negligible.

KJ worked with Santa Rosa staff to collect the necessary data to create the baseline energy profile in a spreadsheet model entitled "Santa Rosa Energy Baseline." Baseline data were developed using daily operating data from the Santa Rosa SCADA system and monthly billing data from PG&E for the period of January 2012 through December 2013.

For the Recycled Water System, the electricity baseline energy usage was broken down into Pumping and Pond categories, which respectively include data from PG&E and the SCADA system. The baseline is summarized in Table 3-4.

Table 3-4: Baseline Electricity Usage for the Recycled Water System

Category	Baseline Annual Electricity Use (kWh/Yr)	Baseline Annual Electricity Cost (\$/Yr)
Recycled Water Pumping ¹	1,594,000	\$350,000
Recycled Water Pond ²	78,000	\$6,000
Total Electricity Used for Recycled Water System	1,672,000	\$356,000

¹ Data are from PG&E from January 2012 to December 2013.

² Data are from Santa Rosa SCADA system from January 2012 to December 2013, excluding March and October 2012.

As shown in Figure 3-2, the Recycled Water System uses a relatively small percentage (approximately 5%) of the total electricity of the Subregional System.

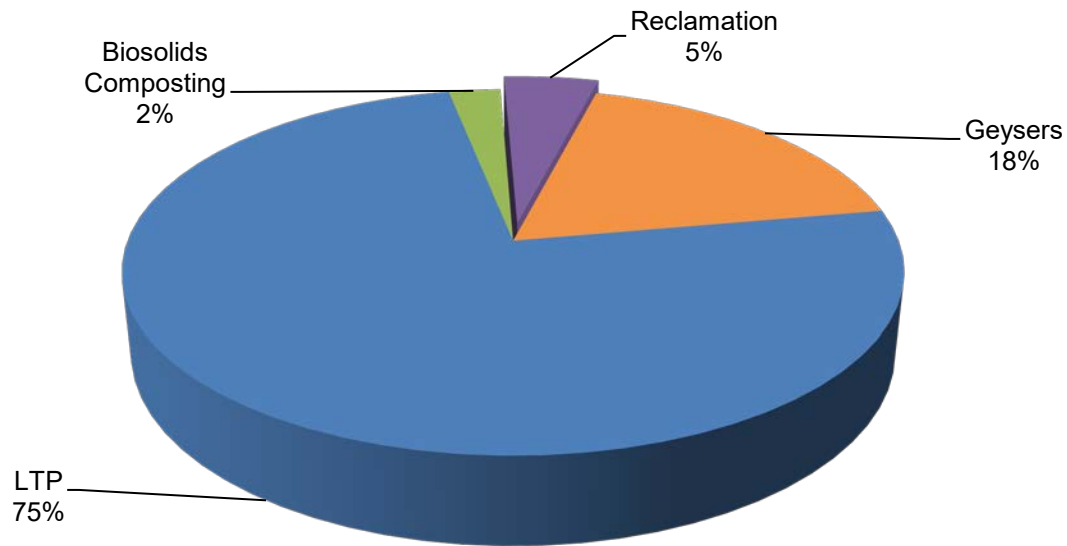

Figure 3-2: Annual Electricity Usage for Subregional System by Category

3.3 Overview of Audit Methodology

The Recycled Water System energy audit involved looking at all pump stations and pipelines that convey recycled water; and assessing the cost-effectiveness and energy savings of changing the operation of the equipment, retrofitting the existing equipment, or replacing the existing equipment with a more energy efficient option. In addition, the audit evaluated treatment processes at LTP that relate to recycled water production to identify changes that could lower costs and save energy (further described in TM #1 – LTP Process Energy Audit).

Audit Participants

Audit participants included staff from Santa Rosa and KJ. Dawn Taffler and Rod Houser (the audit team) met with Randy Piazza, Karl Righetti, and Rip Forrey to discuss the audit process for Santa Rosa. The audit focused on the evaluation of recycled water pump stations and the level of treatment and disinfection needed to meet regulatory requirements and customer demands for recycled water.

Audit Methodology

The energy audit consisted of both an off-site review of data, a workshop with Santa Rosa staff, and an on-site tour of some recycled water conveyance system infrastructure. The objective of the audit was to understand the operation of conveyance infrastructure to identify all of the equipment and operational practices that consume energy, provide a detailed assessment of energy using equipment, quantify their energy use, and identify preliminary EEMs.

The audit included a workshop conducted by Dawn Taffler and Rod Houser of KJ, who led participants through a discussion of operations, energy use, and performance. Staff was willing to explore incorporating many of the ideas into the operations of the Recycled Water System. The audit relied heavily on the operation-specific knowledge and experience of Santa Rosa staff, and the workshop allowed an exchange of information that increased the number and applicability of the recommendations.

The seven EEMs were identified during the workshop and tour and are listed in Table 3-5.

Table 3-5: List of Identified Energy Efficiency Measures (EEMs)

EEM #	Category	Title
1	Treatment Process Improvements	Produce Two Recycled Water Qualities
2		Replace UV Disinfection ¹
3	Pump Station Improvements	Eliminate Pressure Relief Bypass
4		Incorporate VFDs
5		Reduce Deliver Pressures to Select Customers
6	Customer-Focused Improvements	Optimize Operations for Time of Use Rates

¹ The replacement of UV disinfection is described and evaluated in TM #1 – LTP Process Energy Audit.

Data Review

Prior to the onsite audit, KJ reviewed data provided by PG&E and Santa Rosa, including: maps of customers and infrastructure (Attachment B); energy usage and cost per customer; recycled water flow data by pump station and/or customer accounts; a pump improvements list identifying pumps that have magnetic meters, e-valves, VFDs, SCADAs, pressure tanks, PLC, filter systems, or Cl injection (Attachment C); and a Santa Rosa assessment of pump efficiency.

Santa Rosa provided a list of pump stations they perceived to operate efficiently and inefficiently. The pump station efficiency evaluation metrics for these pump stations are summarized in Table 3-6.

Table 3-6: Pump Station Efficiency Evaluation by Santa Rosa

Pump	Motor Horsepower (HP)	Recycled Water Deliveries (MG)	PG&E Average Annual Energy (kWh)	PG&E Average Annual Cost (\$)	Specific Energy Requirements ¹ (kWh/MG)	Unit Cost Per Flow (\$/MG)
Pump Stations Identified by Santa Rosa as "EFFICIENT"						
Beretta North	40 HP	42	31,435	\$6,908	754	\$166
McClelland Dairy	75 HP	97	106,956	\$14,908	1,099	\$153
Pump Stations Identified by Santa Rosa as "INEFFICIENT"						
Mello- East	50 HP	49	53,368	\$10,548	1,094	\$216
Lafranconi-West	50 HP	76	73,227	\$12,576	970	\$167
Dei South²	60 HP	52	44,678	\$12,162	853	\$232
Terri Linda²	60 HP	69	56,431	\$11,251	822	\$164
Dei Home	30 HP	45	31,488	\$7,665	705	\$172
Lafranconi-Pipeline³	25 HP	33	N/A	N/A	N/A	N/A

¹ Calculated by dividing recycled water deliveries by energy data from PG&E on a monthly basis and taking the average of the values over the year.

² These pump stations are currently be updated.

³ No data available from PG&E.

(Source: Randy Piazza, City of Santa Rosa 4/1/14)

Further evaluation of pump efficiency was conducted by KJ using PG&E data and recycled water flow data from Santa Rosa. The review of data included reconciling the different meter numbers and pump station identifiers between the PG&E and Santa Rosa data sets and identifying pump stations with more than one pump. A summary of pump station account numbers, addresses and meter identifications are included in Attachment D.

The energy evaluation was based on input from Santa Rosa and the following assumptions:

- Recovery pumps, pumps no longer in service and pumps that did not have a motor greater than 10 horsepower (HP), were assumed to not have a large impact on Santa Rosa's efficiency and were excluded from the analysis. A list of pumps that were excluded from the analysis is provided in Attachment E.
- Pump names are based on pump locations on the map provided by Santa Rosa.
- Pump stations were identified using the map provided by Santa Rosa while the "pumps at pumps stations" column in Attachment D was named from the "pump list" in the spreadsheet provided by Santa Rosa. Santa Rosa verified that the pumps at pump stations were matched up correctly.
- Service (SVC) numbers in the pump station list from Santa Rosa were used to match up with the SAID numbers in the spreadsheet PG&E spreadsheet. Santa Rosa assisted in matching pump station names for flow from recycled water with the pump stations listed in the PG&E spreadsheet.
- Monthly flow data for recycled water was provided by Santa Rosa from 2011 to 2013.
- Monthly energy and cost data was provided from PG&E from 2011 to 2013.
- Specific energy requirement of kilowatt-hour per million gallon (kWh/MG) was calculated by dividing energy usage data from PG&E by flow data from recycled water.

- Unit cost (\$/MG) was calculated by dividing the cost data from PG&E by the recycled flow data. Similar to specific energy requirement, unit cost values divided the three-year sum of each value; not by taking the average of the three years.

A summary of the pump station efficiency evaluation is provided in Table 3-7. Pump stations are sorted from highest to lowest specific energy requirement (kWh/MG) to determine which pumps should be further analyzed to incorporate EEMs.

This audit mainly focuses on specific energy requirement (kWh/MG) because it provides insight into pump efficiency. Currently, Vanazza pump station has the highest specific energy requirement of approximately 2,500 kWh/MG and should be explored to incorporate EEMs to improve efficiency. Other pumps that should be further analyzed for implementing EEM measures are Morrison/N West 30 HP, Hansen F West, Robbins, and Todd Road Pump Station. Further evaluation of how these five pumps can reduce their specific energy requirement is described in Section 3.4.

Only 26 out of the 44 pumps had flow and energy data. KJ could not perform an analysis on the pumps for which data were not available (N/A), but recommends that in the near future Santa Rosa gathers the appropriate information to analyze the efficiency of these 18 pumps.

Table 3-7: Pump Station Efficiency Evaluation

Pump Station ¹	Motor (HP)	Energy and Flow Data (2011-2013)					
		Flow (MG/Yr) ²	Metered Energy (kWh/Yr) ³	Cost (\$/Yr) ⁴	Specific Energy Requirement (kWh/MG) ⁵	Cost Per Flow (\$/MG) ⁶	Cost per Energy (\$/kWh) ⁷
VANAZZA	75	4.5	10,200	\$3,800	2,503	\$926	\$0.34
MORRISON/N WEST 30HP	30	27.0	57,500	\$11,400	2,155	\$426	\$0.17
HANSEN F WEST	40	11.5	19,800	\$5,100	2,138	\$542	\$0.24
ROBBINS	20	8.4	14,100	\$3,400	1,688	\$401	\$0.23
KELLY FARM	300	57.8	81,400	\$17,900	1,500	\$351	\$0.20
TODD RD PS	20,30, 30,30	28.0	38,600	\$9,600	1,464	\$362	\$0.25
MORRISON /S.WEST	15	7.4	9,600	\$2,500	1,413	\$405	\$0.24
HANSEN F EAST	30,10	45.9	53,000	\$8,900	1,158	\$195	\$0.16
TOMROSE	30	13.4	14,900	\$4,200	1,119	\$311	\$0.27
OAKRIDGE	25	8.8	9,700	\$3,300	1,114	\$384	\$0.35
DENNER AG PUMPS 525HP	525	160.4	176,000	\$39,400	1,104	\$247	\$0.21
PETERS DAIRY	75	80.6	87,600	\$13,900	1,091	\$179	\$0.19
DEI SOUTH	60	42.1	43,400	\$11,000	1,072	\$271	\$0.25
MELLO A JR E	50	52.6	52,100	\$10,100	1,000	\$195	\$0.20
MUELRATH HM	20,30	29.1	29,300	\$7,500	983	\$254	\$0.28
CHRISTENSEN S	20	12.5	11,600	\$1,700	925	\$252	N/A
TERRI LINDA	60	45.5	40,100	\$9,400	894	\$221	\$0.25

Pump Station ¹	Motor (HP)	Energy and Flow Data (2011-2013)					
		Flow (MG/Yr) ²	Metered Energy (kWh/Yr) ³	Cost (\$/Yr) ⁴	Specific Energy Requirement (kWh/MG) ⁵	Cost Per Flow (\$/MG) ⁶	Cost per Energy (\$/kWh) ⁷
LAFRANCONI WEST	50	79.0	69,600	\$11,200	887	\$143	\$0.15
BERETTA SOUTH	60	42.6	35,200	\$7,500	836	\$178	\$0.21
HENRY 15HP	15	11.6	9,400	\$2,700	816	\$230	\$0.28
BERETTA RNCH	40	39.3	29,000	\$6,300	733	\$160	\$0.24
MUELRATH S	15	9.6	7,000	\$2,100	722	\$216	\$0.29
#1384 DEI HOME	30	46.3	31,800	\$7,200	693	\$157	\$0.22
MATOS 30HP	30	52.3	27,700	\$6,500	599	\$142	\$0.24
#3066 - ALPHA FARM	200	75.7	34,800	\$11,900	441	\$163	\$0.17
AMBROSINI HOME 20HP	20	17.5	N/A	N/A	N/A	N/A	N/A
MACK	20	0.3	N/A	N/A	N/A	N/A	N/A
MELLO A JR W	20	24.6	N/A	N/A	N/A	N/A	N/A
AGGIO	100	54.5	N/A	N/A	N/A	N/A	N/A
AMATO	60	15.3	N/A	N/A	N/A	N/A	N/A
CARINALLI	125	53.4	N/A	N/A	N/A	N/A	N/A
DOTTI BROS	75	76.1	N/A	N/A	N/A	N/A	N/A
GLEASON PUMP	60	48.3	N/A	N/A	N/A	N/A	N/A
HANSEL PMP	40	3.1	N/A	N/A	N/A	N/A	N/A
AG LAFRANCONI PIPELINE	25	33.0	N/A	N/A	N/A	N/A	N/A
NOMMSE C	N/A	22.0	N/A	N/A	N/A	N/A	N/A
A PLACE TO PLAY	30	17.7	N/A	N/A	N/A	N/A	N/A
LA FRANCHI	140	56.1	N/A	N/A	N/A	N/A	N/A
WTR TRTM PONCIA PMP ST	350	269.1	N/A	N/A	N/A	N/A	N/A
STONE	100	42.0	N/A	N/A	N/A	N/A	N/A
#3066 - BROWN	250	217.4	N/A	N/A	N/A	N/A	N/A
DELTA POND PMP STA 600	300, 300, 75,20	N/A	352,500	\$50,400	N/A	N/A	\$0.14
LAFRANCONI EAST	40	N/A	N/A	N/A	N/A	N/A	N/A
AMBROSINI/WCII 20HP	20	10.5	N/A	N/A	N/A	N/A	N/A

¹ Pump Station name provided by City of Santa Rosa. See Attachment D for account information and meter numbers.

² 3-year average annual recycled water deliveries reported by Santa Rosa (monthly meter readings from 2011-2013).

³ 3-year average annual energy use reported by PG&E (monthly meter readings from 2011-2013).

⁴ 3-year average annual energy cost reported by PG&E (monthly meter readings from 2011-2013).

⁵ Calculated by dividing the annual flow by the annual energy use. Presented as the three-year average from

Pump Station ¹	Motor (HP)	Energy and Flow Data (2011-2013)					
		Flow (MG/Yr) ²	Metered Energy (kWh/Yr) ³	Cost (\$/Yr) ⁴	Specific Energy Requirement (kWh/MG) ⁵	Cost Per Flow (\$/MG) ⁶	Cost per Energy (\$/kWh) ⁷

2011-2013.

⁶ Calculated by dividing the annual cost by the annual flow. Presented as the three-year average from 2011-2013.

⁷ Calculated by dividing the annual cost by the annual energy use. Presented as the three-year average from 2011-2013.

N/A = data not available at time of this Tech Memo.

3.4 Detailed Descriptions of Recommended EEMs

This section describes the details of the four recommended EEMs and provides financial summaries. Calculated values are based on rough order of magnitude estimates and what is believed to be the best available data. The cost estimates are based on the Association for the Advancement of Cost Engineering International (AACEI) standards for Class 5 planning level cost estimating with an estimated accuracy range between +50% and -30% suitable for comparison purposes between alternatives or options. Incentives amounts are based on best estimates and need to be verified by applying to the appropriate PG&E program.

EEM 2 – Replace Ultraviolet (UV) Disinfection

The objective of this EEM is to reduce energy consumption by exploring options to replace the use of UV disinfection with a less energy intensive disinfection option. The detailed analysis of this EEM is provided in TM#1 – LTP Process Energy Audit (EEM #2).

EEM 3 – Eliminate Pressure-Relief Bypass

Incorporating hydropneumatic tanks at pump stations, in lieu of pressure relief bypasses, has the potential to increase pump station energy efficiency. Currently, pressure relief bypass systems are used at Todd and Rohnert Park (Poncia) pump stations to limit maximum discharge pressures when demand is less than pump output. The bypass routes excess pumpage back to the pump suction, which results in the recirculation of water and unnecessary energy consumption. Hydropneumatic tanks can be used to store excess pumpage, in place of constant recirculation. A pressure switch on the pump discharge is then used to cycle power to the pump to maintain the discharge pressure within an allowable operating band that corresponds to the best efficiency point of the pump(s).

Santa Rosa currently has four hydropneumatic tanks that are in use at Denner, Rohnert Park, Countyside, and Finley pump stations. A fifth hydropneumatic tank is located near the Todd Rodd Pump Station, which is currently not integrated in the system but planned for installation in 2014. There are no other plans for installing hydropneumatic tanks at other reclamation pump stations.

Todd Road Pump Station

Todd Road pump station consists of four pumps (one 20 HP and three 30 HP). A 1,000 gallon hydropneumatic tank, from another decommissioned pump station, has been placed at the Todd Road pump station site (see Figure 3-3). Santa Rosa recently installed new VFDs at the Todd Road pump station, as well as a bypass. Connecting to the hydropneumatic tank would address Santa Rosa's current recirculation problem due to the existing the bypass relief valves. The hydropneumatic tank would provide a small amount of usable storage that allows the pumps to cycle on and off when demands are less than pump output. Ideally, the relief bypass valves would only be used in emergency situation if there was a failure of the pressure regulation controls.

The Energy Efficiency Audit and Retrofit Options for the Todd Reclamation Booster Pump Station (Lescure, 2013) also recommended incorporation of the hydropneumatic tank. Connecting the hydro tank creates an estimated annual energy reduction of approximately 2,930 kWh, an estimated \$36,000 capital cost, and an annual average net energy savings of approximately \$1,240 per year (calculated based on the difference between the VFD plus Hydro Tank Option and the VFD Only Option provided in the Lescure report). It is recommended that Santa Rosa install the hydropneumatic tank Todd Road pump station to realize the full potential energy savings.

An incentive may be available from PG&E through its Customized Retrofit Incentive program for this EEM (<http://www.pge.com/en/mybusiness/save/rebates/ief/index.page>).



Figure 3-3: Disconnected Hydropneumatic Tank at Todd Road Pump Station

EEM 5 – Reduce Delivery Pressures

Targeting pump stations with high specific energy requirements for pump replacement may be a viable way to reduce energy consumption. There are two possible causes for pump stations with high specific energy requirement: (1) the existing pump(s) are inefficient given the operating duty condition they are operating on, and (2) the delivery pressure(s) to end users are higher than typical. It is also possible for both of these conditions to occur simultaneously.

Small pump stations, dedicated to individual users, that have a calculated specific energy requirement of greater than 1,200 kWh/MG (the average of all pumps in Table 3-7), were evaluated to estimate the potential savings due to replacement with more efficient pumps. The calculated energy savings, estimated capital costs, and estimated average annual savings for each pump replacement is shown in Table 3-8.

Delivering water at lower pressures may not be acceptable at every location, depending on the topography of the site and type of use. For example, properties at higher elevation require high pressure to serve and vineyards that rely on drip irrigation may require less energy than pastures irrigated by larger rotary sprinklers.

Santa Rosa provided a list of water delivery pressures for all the pump stations listed in Table 3-7 and a description of the typical use and/or conditions where known.

Table 3-8: Pump Replacement to Reduce Specific Energy Requirement

Pump Station	Estimated Energy Savings (kWh/Yr)¹	Estimated Capital Costs (\$)²	Estimated Cost Savings (\$/Yr)³
VANAZZA	4,800	\$45,000	-\$2,700
MORRISON/N WEST 30 HP	25,100	\$18,000	\$2,600
HANSEN F WEST	6,000	\$24,000	-\$900
ROBBINS	4,100	\$12,000	-\$300
MORRISON /S.WEST	700	\$9,000	-\$600

¹ Calculated based on a design specific energy requirement of 1,200 kWh/MG multiplied by the metered flow minus the metered energy (metered data from 2011-2013 listed in Table 3-7).

² Estimated based on \$600/HP replacement cost.

³ Calculated based on the estimated energy savings multiplied by the unit cost per energy from Table 3-7.

Due to the modest energy savings versus the capital costs for most of the pumps, only replacement of the Morrison/N West 30 HP pump results in an estimated savings for Santa Rosa, and is shown in Table 3-9.

Table 3-9: EEM-5 Reduce Delivery Pressures Summary

Electricity Savings (kWh/Yr)	Electricity Savings (\$/1st Yr)	GHG Emission Reduction (MT/Yr)	Capital Cost (\$)	Incentive Amount (\$)	Avg Annual Net Savings (\$/Yr)	NPV of Cumulative Net Savings (\$)
25,100	\$2,690	5	\$18,000	\$0	\$2,000	\$22,200

Santa Rosa currently charges three rates for recycled water: one for sites requiring high-pressure deliveries, one for sites with low-pressure deliveries, and a third for sites where Santa Rosa provides additional equipment for operations. Santa Rosa may want to further investigate the existing tiered rate structure to consider a more equitable distribution or allocation of costs for pumps that are consistently operating at high specific energy. While this is more of a management and policy issue, Santa Rosa could recognize significant energy cost savings without a capital cost investment.

EEM 6 – Optimize Operations for Time of Use Rates

PG&E electricity rates vary significantly depending on the time of day. Limiting pumping during peak electricity rate periods can significantly decrease electricity costs for the Recycled Water System. PG&E has a cost multiplier that is applied depending on the time of day and season electricity is consumed. The most expensive period is during peak hours from 1 pm to 8 pm and the least expensive period is during night non-peak hours from 11 pm to 6 am. Summer months are generally more expensive during the day, though winter months can have higher night time rates. Current PG&E time of day factors can be found on their website.

Ideally, all Recycled Water System pumps would be operated at night, when energy demands and costs are lowest. Santa Rosa controlled pump stations are mostly operated in the evening, though some pumping occurs during the day time to fill ponds from LTP. Santa Rosa has also made continuous efforts to encourage agricultural users to irrigate at night, to improve water efficiency, and reduce pumping during peak electricity periods.

Limitations to night-time irrigation include:

- Farms that rely on manual labor to move hand lines and wheel lines to provide full coverage irrigation of their fields require mostly daytime irrigation.
- Monitoring runoff is more difficult in the evening.
- Response to leaks and/or line breaks would be slower during off-work hours.

The electricity energy cost evaluation looked at pumps with higher unit electricity costs, representative of pump stations that may not currently be operating at the optimal time based on the higher electricity rates applied for day time operations. The pumps in Table 3-7 show a range in

metered unit electricity cost from \$0.14/kWh to \$0.35/kWh and an average unit electricity cost of \$0.23/kWh. Table 3-10 lists the calculated electricity cost savings if pumps that had a greater than average unit electricity cost were to operate at a unit electricity costs equal to \$0.23/kWh. In other words, this EEM assumes that pumps with higher unit electricity costs would change operations to irrigate in a more similar manner to the average pump station in Santa Rosa's Recycled Water System. Electricity demand (kW) savings are not included.

The modest electricity savings associated with this EEM are because it only assumes a shift in electricity use to some off-peak hours and an average annual cost per electricity of \$0.23/kWh. Enforcement of this EEM will be challenging because many agricultural users rely on day-time staff to provide manual irrigation. Potential risks associated with line breaks and regulatory repercussions from runoff are further deterrents to implementation. Additional studies may be warranted to identify and track customers who are not encumbered by irrigation time-of-day operations and methods that could be employed to limit potential risks associated with leak response time.

Table 3-10: Electricity Cost Savings from Optimizing Time of Use Operations

Pump	Average Annual Cost per Electricity (\$/kWh) ¹	Average Annual Electricity Cost (\$/Yr) ¹	Optimized Electricity Cost (\$/Yr) ²	First Year Estimated Electricity Cost Savings (\$/Yr) ³
OAKRIDGE	\$0.35	\$3,300	\$2,200	\$1,100
VANAZZA	\$0.34	\$3,800	\$2,300	\$1,500
MUEL RATH S	\$0.29	\$2,100	\$1,600	\$500
MUEL RATH HM	\$0.28	\$7,500	\$6,700	\$800
HENRY 15 HP	\$0.28	\$2,700	\$2,200	\$500
TOMROSE	\$0.27	\$4,200	\$3,400	\$800
TODD RD PS	\$0.25	\$9,600	\$8,900	\$700
DEI SOUTH	\$0.25	\$11,000	\$10,000	\$1,000
TERRI LINDA	\$0.25	\$9,400	\$9,200	\$200
HANSEN F WEST	\$0.24	\$5,100	\$4,600	\$500
MORRISON/ S.WEST	\$0.24	\$2,500	\$2,200	\$300
MATOS 30 HP	\$0.24	\$6,500	\$6,400	\$100

¹ Metered billing data from 2011-2013 listed in Table 3-7.

² Calculated as optimal \$0.23/kWh multiplied by the metered electricity.

³ Calculated as metered cost minus optimized electricity cost.

Table 3-11: EEM-6 Optimize Operations for Time of Use Rates Summary

Electricity Savings (kWh/Yr)	Electricity Savings (\$/1st Yr)	GHG Emission Reduction (MT/Yr)	Capital Cost (\$)	Incentive Amount (\$)	Avg Annual Net Savings (\$/Yr)	NPV of Cumulative Net Savings (\$)
0	\$8,000	0	\$10,000	\$0	\$10,200	\$146,900

3.5 Detailed Descriptions of EEMs Not Recommended

EEM 1 – Produce Two Recycled Water Qualities

A summary of recycled water uses allowed in California are listed in Attachment B. Santa Rosa currently produces Title 22 disinfected recycled water recycled water, suitable for unrestricted non-potable reuse. Some of Santa Rosa's existing customers could be served with secondary treated recycled water. For example, pasture for milk animals for human consumption are allowed to have disinfected secondary-2.2 and/or disinfected secondary-23 recycled water. Reducing the level of treatment could reduce the energy demands associated with the additional treatment.

The minimum level of treatment for recycled water is limited based on the following contractual and regulatory requirements for end users:

1. Geysler Steamfield (Calpine Contract) requires disinfected tertiary recycled water.
2. Urban users (Rohnert Park and Santa Rosa URP) require Title 22 disinfected tertiary recycled water due to the level of human contact.

Though disinfected secondary recycled water may be suitable for some existing agricultural uses, serving multiple recycled water qualities would have the following challenges:

- Need for additional infrastructure at LTP to produce two water qualities.
- Additional operational complexities to produce two water qualities.
- Need to separate or add an additional disinfection treatment train (one for each water quality produced).
- The existing conveyance backbone pipeline and pond system is structured to serve urban and agricultural customers.
- The costs of developing a parallel reclamation conveyance system would be cost prohibitive.
- The quantity of water delivered to urban and agricultural customers is less than one third of the total recycled water produced.

The requirement to design and build a parallel reclamation treatment and conveyance system for a relatively small amount of recycled water would have a high dollar per unit flow cost and add significant operational complexities; therefore EEM-1 is not recommended.

EEM 4 – Incorporate VFDs

The objective of this EEM is to provide electricity consumption reductions for a pump station by installing a VFD to vary the frequency and the speed of the inner channel pump to maintain desired operating conditions. The Recycled Water System includes 10 large pumps and approximately 40 to 50 small pumps. Many of the existing pumps already have VFDs installed (see Attachment C), demonstrating Santa Rosa's commitment to improving pump efficiency and capturing energy savings. The analysis for this EEM shows that in some cases VFDs may not reduce energy consumption sufficiently to offset the cost of equipment and installation. Energy savings due to the installation of VFDs is a function of the capacity of the pump. Thus, smaller pumps may not see the same energy efficiency benefits as larger pumps; therefore EEM-4 is not recommended.

References

Lescure Engineers, Inc. 2013. Energy Efficiency Audit and Retrofit Options for the Todd Reclamation Booster Pump Station. Prepared for the City of Santa Rosa. January 2013.

PG&E. 2013. Frequently Asked Questions PG&E's Power Purchase Agreement for Small Renewable Generation "Feed-in Tariffs". Pacific Gas and Electric Company. Retrieved on 5 March 2014.

http://www.pge.com/includes/docs/pdfs/b2b/wholesaleelectricssuppliersolicitation/Feedin_Tariffs_FAQs.pdf

Attachment A: Recycled Water Storage Pond Layout

See PDF at the end of this TM.

Attachment B: Recycled Water Uses Allowed in California

See PDF at the end of this TM.

Attachment C: Recycled Water Pump Station Improvements as of April 2014

LOCATION	MAG METER	E-VALVE	VFD	SCADA	PRESSURE TANK	PLC	FILTER SYSTEM	CL INJECTION	NOTES
AGGIO	X	X		X					manure pump
ALPHA IRR			X	X			X		
ALPHA RECOVERY									
AMBROSINI HOME		X		Z?		Z?			
AMBROSINI POND									
APTP	X		X	X			X	X	3 pumps; 2 irrigation - 1 prs. pump; on demand
BALLETTO OCCIDENTAL									Pond; has 2 diesel & 1 electric motors
BALLETO GUERNVILLE									Off mainline has diesel motor
BERETTA NORTH	X	X	X	X					manure pump
BERETTA SOUTH	X	X	X	X					
BEVILL									Off mainline has diesel motor
BRADY									
BROWN IRR			X	X			X		
BROWN RECOVERY									
CARINELLI	X	X		X					Valve control of flow
CHRIST S									
COUNTYSIDE			X	Z?	X		X		On demand station
DEI NORTH/HOME									
DEI SOUTH	Z	Z		Z					summer/fall 2014
DENNER	X	X	X	X	X		X		4 pumps; 2 vfd's; 2 soft start
DOTTI	X	X		X					Valve control of flow
FOXTAIL	X	X		X					Pond fill off mainline; 3 valves
FREITAS IRR							X		
FREITAS WELL									
GLEASON/NEIMENS	x	x		x					

LOCATION	MAG METER	E-VALVE	VFD	SCADA	PRESSURE TANK	PLC	FILTER SYSTEM	CL INJECTION	NOTES
HANSEL / CHRIST. N									
HANSEN EAST	X	X	X	X			X		2 pumps; 1 VFD; 2 valves
HANSEN WEST	X	X		X			X		
IDYLEWILD/BRENTWOOD		X				X			Valve control of flow
KAHN/HENRY		Z				Z			
KELLY IRR	X		X	X			X		
KELLY RECOVERY									
LAFRANCONI EAST									
LAFRANCONI MIDDLE	Z	X		Z					
LAFRANCONI WEST	Z	X		Z					
LEE									
MACK									
MATOS		X				Z			
MELLO EAST	Z	Z		Z					
MONONI									
MORRISION NORTH	Y	X		Y					manure pump
MORRISION SOUTH		X				Y			
MUELRATH HOME		X				Z			
NOMMSEN									Pump station plus off Todd Rd. PS
NONELLA									
OAKRIDGE/SR RIDING CTR.	Z?	X		Z?		Z?			
O'NEEL/VANAZZA									Vineyard
PACHECO									Has pond that is filled from Brown thru Dotti
PETERS	X	X		X					
PONCIA HOME	X	X	X	X					Off RPPS
PONCIA TERRI-LINDA	Z	Z		Z					

LOCATION	MAG METER	E-VALVE	VFD	SCADA	PRESSURE TANK	PLC	FILTER SYSTEM	CL INJECTION	NOTES
RANCHO LAGUNA	X	X	X	X					2 pumps; 1 VFD; 1 soft start
ROBBINS	X								Off Ambrosini pond thru Korbel sump
RPPS	X		X	X	X		X	X	
SANCHETTI HOME									Pond; cng powered motors
SANCHETTI PARK ROYAL									Pond; cng powered motors
SANCHETTI/RASMUS SEN									Pond; cng powered motors; off Ambrosini pond
STONE	X	X		X					
SUNRISE		X				Z			
TODD RD PS	X	X	Y	X	Z				2 valves; wells/trunk line
TOMROSE		X	X			Z			
WC IRR/FINLEY	X		X	X	X		X	X	
WELLS/STRUNK VALVE		X				Z			Runs off Todd Rd. PS
WINKLER/MUEL RATH SOUTH		X				Z			

Source: Email from Rip Forrey on 5 May 2014

X=existing

Y=installed/non-operational

Z=proposed

It should be noted that all pump stations have a flow meter, though some meters have been recently updated.

Attachment D: Background Recycled Water Pump Station Information

Pump Stations	Pumps at Stations	Address	Account Number	City Meter ID	PG&E Meter ID
Dei	#1384 DEI HOME	831 HIGH SCHOOL RD	6314244758	880R64	880R64
	DEI SOUTH	831 HIGH SCHOOL RD	2549728005	X04891	1003202603
Terri Linda	TERRI LINDA	597 WILFRED AVE	6314244766	5190R8	1009921404
LaFraconi	AG LAFRANCONI PIPELINE	2500 LLANO RD	6314244562	26277R	N/A
	LAFRANCONI WEST	1811 LUDWIG AVE	6314244652	34M162	34M162
	LAFRANCONI EAST	1811 LUDWIG AVE	6314244648	33M862	1008840167
Mello	MELLO A JR	2700 LLANO RD	8439244212	35P476	35P476
	MELLO A JR (WEST)	2700 LLANO RD	6314244564	26304R	N/A
Beretta	BERETTA SOUTH	3215 LLANO RD	6314244516	4963R5	5000034202
	BERETTA RNCH	3233 LLANO RD	4855905020	47447R	5000034176
Todd RD PS	TODD RD PS	LLANO RD & COLGAN CREEK	6314244528	5090R2	1009513114
Nommsen	NOMMSE C	3915 LLANO RD	6314244532	1778R3	N/A
Matos	MATOS 30 HP	3669 LLANO RD	6314244536	880R32	1009927338
Hansen	HANSEN F WEST	3420 GUERNEVILLE RD	6314244544	1M1052	5000033586
	HANSEN F EAST	3420 GUERNEVILLE RD	6314244546	0497R6	1006491524
Dotti	DOTTI BROS	2145 LLANO RD	8439244552	#N/A	N/A
Carinalli	CARINALLI	2600 LLANO RD	6314244572	1M0557	N/A
Kelly Farm	KELLY FARM	5344 OCCIDENTAL RD	8439244968	2P2639	1004778120
Hansel	HANSEL PMP	5700 HALL RD	6314244592	34M236	N/A
GLEASON PUMP	GLEASON PUMP	5915 HALL RD	6314244596	47499R	N/A
Amato	AMATO	435 SANFORD RD (SR HORSE CO)	6314244598	603R38	N/A
Stone	STONE	5743 OCCIDENTAL RD STONE	6314244662	X02504	N/A
Christensen S	CHRISTENSEN S	600 SANFORD RD	6314244666	X18883	5000034010

Pump Stations	Pumps at Stations	Address	Account Number	City Meter ID	PG&E Meter ID
Ambrasini	AMBROSINI HOME 20 HP	4265 HALL RD	6314244682	1P8925	N/A
	AMBROSINI/WCII 20 HP	4265 HALL RD	6314244686	44612R	1008842153
Mack	MACK	4735 HALL RD	6314244684	6504R3	5000033561
Henry	HENRY 15 HP	497 LAGUNA VISTA RD	6314244688	P98824	5000034025
VANAZZA	VANAZZA	5151 HALL RD	6314244692	OM9898	5000034199
Morrison	MORRISON /S.WEST	5157 STONY POINT RD	6314244776	47433R	5000033549
	MORRISON/N WEST 30 HP	5157 STONY POINT RD	6314244784	X45746	1005515491
Mulerath	MUEL RATH HM	3800 WALKER AVE - MUEL RATH	4855905010	X05382	5000033595
	MUEL RATH S	3800 WALKER AVE	8124437855	#N/A	5000102181
Tomrose	TOMROSE	5307 STONY POINT RD	3028550857	X34208	5000033565
Oakridge	OAKRIDGE	3184 GUERNEVILLE RD	4855905025	M15532	1006491491
Alpha Pond	#3066 - ALPHA FARM	3600 LLANO RD	4855905068	20P699	20P699
Place to Play	A PLACE TO PLAY	2375 W 3RD ST	6314244498	0458R0	N/A
Robbins	ROBBINS	3086 GUERNEVILLE RD	4855905458	97939R	1009945946
Aggio	AGGIO	5915 HALL RD	4855905040	89R116	N/A
Rancho Laguna	LA FRANCHI	4000 PINER RD - RANCHO LAGUNA	4855905045	2840R8	N/A
Denner	DENNER AG PUMPS 525 HP	4390 WOOLSEY RD	4855905512	P29180	1004779272
Peters Dairy	PETERS DAIRY	3600 WOODWORTH RD	4855905070	47489R	1009869348
Rohnert Park	WTR TRTM PONCIA PMP ST	5200 STONY POINT RD	4855905075	P30564	N/A
Delta Pond	DELTA POND PMP STA 600	WILLOWSIDE RD	4855905272	2P2634	1009398262
Brown Pond	#3066 - BROWN	2200 LLANO RD	8439244901	2P2638	N/A

* This table identifies which pump stations have one or more pumps

Attachment E: Recycled Water Pumps Excluded from Analysis

ACCOUNTS EXCLUDED	REASONING
FREITAS TREE FARM	10 HP or Under
LEE #86-2980 CTY AG PS	10 HP or Under
IRRIG BRADY 7.5 HP	10 HP or Under
CNTYSIDE IRRIG LNDSCPE	10 HP or Under
PARK AVE TURF 10 HP	10 HP or Under
MONONI	10 HP or Under
WSTE WTR 30 HP CITY	Pump Removed
SEBASTOPOL	Pump Removed
PARK AVE. TURF	Recovery Pump
#3066 - BROWN REC	Recovery Pump
ALPAH REC	Recovery Pump

February 17, 2015

Final Technical Memorandum #3a (Amendment)

To: Mike Sherman, Mike Prinz and Colin Close City of Santa Rosa

From: Rod Houser, P.E., BCEE – Reclamation System Audit Lead for amendment
Julia Lund, PE, LEED AP – Deputy Project Manager
Alan Zelenka – Kennedy/Jenks Project Manager

Subject: Task 1.3a - Reclamation System Energy Audit (Amendment to TM #3)
Energy Optimization Plan (EOP) – Phase 1
K/J Project: 1368024*01

This analysis determines the potential costs and benefits of improvements at two large recycled-water pump stations: Delta Pond Pump Station and the City's B-Pond Pump Station. Improvements at these two pump stations were not contemplated in the original Technical Memorandum #3 (TM) due in part to the lack of energy or demand data that could be used as the benchmark for comparing energy-efficiency measures (EEMs). Since that time, new information was obtained that allows energy savings to be estimated for the following four additional EEMs:

- EEM-8: New Hydropneumatic Tank on West College Section of the Transmission Main
- EEM-9: New Hydropneumatic Tank on Laguna Section of the Transmission Main
- EEM-10: Common Hydropneumatic Tank for Laguna and West College Transmission Mains
- EEM-11: Operate Laguna and West College Transmission Mains at Common Hydraulic-Grade Line (HGL) without a Hydropneumatic Tank

3a.1 Recommendation

None of the four additional EEMs are recommended because they do not provide enough cost savings to offset the capital cost of implementation and there may be operational limitations that would prevent implementation.

While this TM does not recommend any new capital projects or changes to operational practices, there remains some concern over the fact that the rated working pressure of the low-pressure transmission main is unknown. This places a severe limitation on how the system is currently operated, and also limits the range of alternatives that could reduce operational costs in the future.

Additionally, the absence of flowmeters on the City's largest recycled-water pump stations (B Station and Delta Pump Station) makes it difficult to accurately track pump performance and daily/monthly production values.

Therefore, we recommend the following:

- Install flowmeters on the discharge manifolds at E-Station and Delta-Pond Pump Station.
- Research the original design basis for the low-pressure transmission main to establish a safe working pressure rating for the pipeline.
- Review the maintenance history of the pipeline to identify areas where excessive repairs have been made.
- Assess potential EEMs after the working pressure rating has been established.

3a.2 Background

System Description

The supply of reclaimed water is automatically controlled by regulating pump speed to maintain a narrow range of pressures in the low-pressure transmission main. During periods of very-low demand, however, pump output can exceed demand. This is because minimum pump output cannot be reduced beyond a preset threshold, which is usually established by the pump and/or motor manufacture. When the pump is regulated this way, excess pumpage is shunted out of the transmission main to limit maximum pressures. This pressure-limiting control action burns energy that cannot be recovered, so reducing their occurrence should result in a commensurate energy savings.

The principal storage reservoirs involved with this study are located at the Meadowlane complex (Ponds A, B, C and D) next to the Laguna wastewater treatment plant (LTP), and Delta Pond to the north. A third reservoir exists at the West College facility, located approximately midway between the Meadowlane complex and Delta pond. A low-pressure transmission main connects these reservoirs. Additional storage reservoirs have connections to the transmission main, but isolation valves usually prevent transfers of water during the irrigation season.

The low-pressure transmission main is used to convey recycled water from LTP to all of the storage ponds and irrigation pump stations. This pipeline operates at a typical HGL that ranges between elevations 127 feet, near LTP, to elevation 112 feet, near Delta Pond. During the irrigation season, maximum HGL near West College reservoir is usually limited to elevation 111 feet. This is accomplished via an overflow weir that relieves excess pumpage from the Delta Pond pump station. Water stored in this manner is eventually pumped into the City's urban-reuse system or is allowed to drain back into the low-pressure transmission main. Thus, most of the energy consumed during these diversions is later recovered.

A mainline valve is typically closed during the irrigation season to isolate the West College (northern) and Laguna (southern) sections of the transmission main. The same valve is opened during the wet-weather season to allow recycled water to be conveyed from the Meadowland complex northward to Delta Pond, and other reservoirs. The overflow weir at West College reservoir is typically isolated from the transmission main during these periods.

From the Meadowlane complex, irrigation water is supplied by the B pumps at E-Pump Station and B Pond. Pumps EB1, EB2 and EB3 operate in parallel to deliver water out of the E-Station

wet well into the 48-inch Laguna and 30-inch Poncia transmission mains. Pumps B1 and B2 deliver water from Pond B into the Laguna mainline.

During low-demand periods, pumping into the Laguna main is limited to a single variable-speed pump (B1). A programmable logic controller (PLC) maintains a constant pressure in the Laguna section of the transmission main by regulating the speed of pump B1. The minimum-allowable speed of pump B1 is limited, however. Thus, pump output can exceed demand during periods of very-low demand. When this occurs, a motor-operated valve (MOV - B1B) automatically limits the maximum pressure by shunting excess pumpage back to B Pond. While this pressure-limiting action consumes excess energy, City staff report that it is a relatively rare occurrence. The average volume of water shunted back to B Pond cannot be accurately tracked at this time because there is no flowmeter on the bypass line. Thus, for purposes of this analysis, 8% of the pump output at minimum speed (50 gpm) is assumed to flow through MOV – B1B for purposes of pressure regulation.

Energy Use and Cost

This study focuses on the energy wasted when excess pumpage is shunted out of the transmission main. Quantifying this energy is complicated owing to the fact that flows are not measured; therefore estimates and assumptions were made using readily-available information. This included communications with staff, review of standard operating procedures, and several simplifying assumptions.

Energy Consumed Via Overflow Weir at West College Reservoir

Average daily volume supplied from Delta pump station is 2.76 MGD, as summarized in Table 3a-1.

Table 3a-1: Delta Pump Station Historical Output¹

Irrigation Season					
Start	Stop	Days	Recycled Water Volume (Mgal)	Avg Daily Demand (MGD)	Avg Daily Demand (gpm)
6/8/2011	11/7/2011	152	503	3.31	2,290
5/14/2012	11/26/2012	196	456	2.32	1,610
4/13/2013	10/12/2013	182	504	2.77	1,920
	TOTAL	530	1,462	2.76	1,910

Monthly estimates of pump station output were estimated by prorating the average-daily flow based on the reference evapotranspiration (ET_o) for CIMIS Zone 5. These values are summarized in Table 3a-2.

¹ Email, Karl Righetti, City of Santa Rosa, 7/8/14.

Table 3a-2: Estimated Monthly Demands

Reference ET for CIMIS Zone 5			Average Demand	
Month	ET	% of Avg	MGD	gpm
May	5.58	105%	2.90	2,010
June	6.30	119%	3.27	2,270
July	6.51	123%	3.38	2,345
August	5.89	111%	3.06	2,122
September	4.50	85%	2.34	1,621
October	3.10	58%	1.61	1,117

Minimum output of Delta pumps D1P and D3P is estimated at 2,000 gallons per minute [gpm]². Thus, excess pumpage is expected to occur during the months of September and October when demand is less than the minimum pump output. Specific energy of the pump is approximately 186 kWh/Mgal at reduced speed, when delivering 2,000 gpm from Delta Pond (HGL 62 feet) to the West College transmission main (HGL 108 feet). Thus, the excess energy consumed via the overflow weir at West College reservoir is approximately 10,400 kWh per year. Approximately 90% this energy is recovered, however, when water stored in the West College reservoir either drains back into the low-pressure transmission main, by gravity, or is pumped into Santa Rosa's urban-reuse distribution system. Therefore, the net excess energy consumed (i.e., that energy that cannot be recovered) is approximately 1,000 kWh per year.

Energy Consumed Via MOV – B1B

Minimum pump output of pump B1 is estimated to be 600 gpm. This is based on a vertical-turbine pump with a rated condition of 1,900 gpm at 45 feet of head³. Detailed performance data was not readily available, so performance was estimated assuming a two-stage Floway model 14FKH. Specific energy of this pump is 186 kWh/Mgal when delivering 600 gpm from B Pond (HGL 86 feet) to the Laguna transmission main (HGL 127 feet).

Due to the absence of a flowmeter, two key assumptions were made to estimate flows shunted out of the transmission main via MOV-B1B:

- Excess flows occur over 60 days (September and October), similar to Delta pump station.
- 8% of pump output (50 gpm) is shunted back to Pond B during this period.

Using these assumptions, excess energy of approximately 800 kWh per year is consumed by shunting excess pumpage from the Laguna transmission main back to Pond B.

² Based on Peabody-Floway model MKN with a rated condition of 8,000 gpm at 100 feet of head.

³ Standard Operating Procedure for E-Pump Station, City of Santa Rosa, 3/26/2014.

3a.3 Detailed Descriptions of EEMs that are Not Recommended

This section describes the details of the four EEMs that were analyzed but rejected. Calculated values are based on rough order of magnitude estimates and what is believed to be the best available data. The cost estimates are based on the Association for the Advancement of Cost Engineering International (AACEI) standards for cost estimating accuracy of +50% and -30%. Offsetting credits associated with PG&E energy-savings incentives were not considered in this analysis.

EEM-8: New Hydropneumatic Tank on West College Section of the Transmission Main

The objective of this EEM is to eliminate excess discharges to the West College reservoir during periods of low demand. This would be accomplished with three modifications:

- Connect a new 30,000 gallon hydropneumatic tank to the West College transmission main. This could be constructed at any convenient location along the pipeline.
- Isolate the West College overflow weir from the transmission main.
- Modify control logic at the Delta Pond pump station to automatically cycle the pump when pressure exceeds an allowable operating band.

Table 3a-3: EEM-8 New Hydropneumatic Tank on West College Section of the Transmission Main

Electricity Savings (kWh/Yr)	Electricity Savings (\$/1st Yr)	GHG Emission Reduction (MT/Yr)	Capital Cost (\$)	Incentive Amount (\$)	Avg Annual Net Savings (\$/Yr)	NPV of Cumulative Net Savings (\$)
1,000	\$100	<1	\$160,000	\$0	-\$13,000	-\$244,000

EEM-9: New Hydropneumatic Tank on Laguna Section of the Transmission Main

The objective of this EEM is to eliminate excess discharges via MOV-B1B during periods of low demand. This would be accomplished with three modifications:

- Connect a new 7,000 gallon hydropneumatic tank to the West College transmission main. This could be constructed at any convenient location along the pipeline.
- Modify control logic for pump B1 to automatically cycle the pump when pressure exceeds an allowable operating band.

Table 3a-4: EEM-9 New Hydropneumatic Tank on Laguna Section of the Transmission Main Summary

Electricity Savings (kWh/Yr)	Electricity Savings (\$/1st Yr)	GHG Emission Reduction (MT/Yr)	Capital Cost (\$)	Incentive Amount (\$)	Avg Annual Net Savings (\$/Yr)	NPV of Cumulative Net Savings (\$)
800	\$80	<1	\$80,000	\$0	-\$6,900	-\$129,000

EEM-10: Common Hydropneumatic Tank for Laguna and West College Transmission Mains

The objective of this EEM is to eliminate excess discharges via MOV-B1B or the overflow weir at West College reservoir, during periods of low demand. This would be accomplished with four modifications:

- Connect a new 7,000 gallon hydropneumatic tank to the transmission main. This could be constructed at any convenient location along the pipeline.
- Operate the transmission main at a common HGL by opening all mainline valves along the pipeline.
- Modify control logic for pump B1 to automatically cycle the pump when pressure exceeds an allowable operating band.
- Isolate the West College overflow weir from the transmission main.

This EEM would be expected to increase maximum pressures in the West College section of the transmission main by no more than seven psig. This value corresponds to the difference in HGLs previously described for the Laguna and West College transmission mains: elevations 127 feet and 111 feet, respectively.

Table 3a-5: EEM-10 Common Hydropneumatic Tank for Laguna and West College Transmission Mains Summary

Electricity Savings (kWh/Yr)	Electricity Savings (\$/1st Yr)	GHG Emission Reduction (MT/Yr)	Capital Cost (\$)	Incentive Amount (\$)	Avg Annual Net Savings (\$/Yr)	NPV of Cumulative Net Savings (\$)
1,800	\$180	<1	\$80,000	\$0	-\$6,700	-\$126,000

EEM-11: Operate Laguna and West College Transmission Mains at Common HGL without a Hydropneumatic Tank

The objective of this EEM is to eliminate excess discharges via MOV-B1B or the overflow weir at West College reservoir, during periods of low demand. This would be accomplished with three modifications:

- Operate the transmission main at a common HGL by opening all mainline valves along the pipeline.
- Isolate the West College overflow weir from the transmission main.

This EEM would be expected to increase maximum pressures in the West College section of the transmission main by no more than seven psig. This value corresponds to the difference in HGLs previously described for the Laguna and West College transmission mains: elevations 127 feet and 111 feet, respectively. The viability of this EEM is dependent on the maximum-allowable pressure for the transmission main, which could not be verified for this study.

This EEM assumes that the minimum speed for pump B1 could be set such that minimum output corresponds with the minimum combined demand for the common section of transmission main. This approach eliminates the energy wasted via the motorized valve (MOV B1-B) because pump output exactly matches demand at all times.

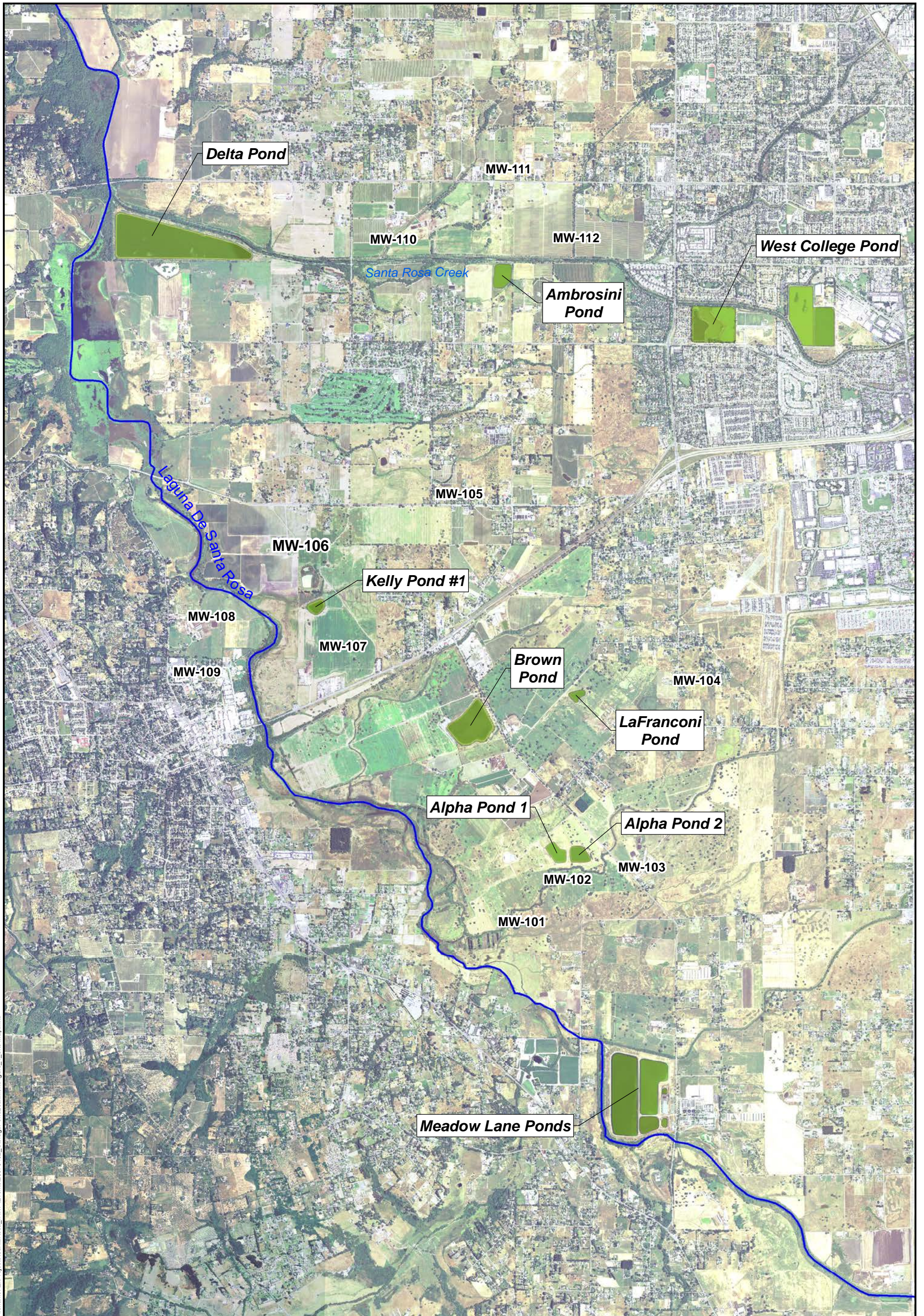

Table 3a-6: EEM-11 Operate Laguna and West College Transmission Mains at Common HGL without a Hydropneumatic Tank Summary

Electricity Savings (kWh/Yr)	Electricity Savings (\$/1st Yr)	GHG Emission Reduction (MT/Yr)	Capital Cost (\$)	Incentive Amount (\$)	Avg Annual Net Savings (\$/Yr)	NPV of Cumulative Net Savings (\$)
1,800	\$180	< 1	\$0	\$0	\$380	\$6,500



Filename: Z:\Projects\SantaRosa_IRWPI\Events\20070402_StoragePond\askMen\Figure_1_Site Map.mxd

LEGEND

-  MW-101 Monitoring Well
-  Pond Location

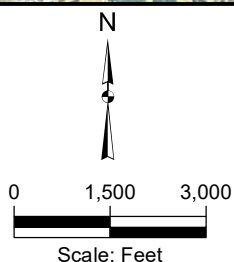

Kennedy/Jenks Consultants
 Santa Rosa Subregional Water Reclamation System
 Santa Rosa, California



**RW Ponds Layout
 Site Map**
 1368024*01
 R / y 2014
 Figure 1

Recycled Water Uses Allowed¹ in California

This summary is prepared for [WateReuse Association](#) from the December 2, 2000-adopted Title 22 [Water Recycling Criteria](#) and supersedes all earlier versions.

Use of Recycled Water	Treatment Level			
	Disinfected Tertiary Recycled Water	Disinfected Secondary-2.2 Recycled Water	Disinfected Secondary-23 Recycled Water	Undisinfected Secondary Recycled Water
Irrigation of:				
Food crops where recycled water contacts the edible portion of the crop, including all root crops	Allowed	Not allowed	Not allowed	Not allowed
Parks and playgrounds	Allowed	Not allowed	Not allowed	Not allowed
School yards	Allowed	Not allowed	Not allowed	Not allowed
Residential landscaping	Allowed	Not allowed	Not allowed	Not allowed
Unrestricted-access golf courses	Allowed	Not allowed	Not allowed	Not allowed
Any other irrigation uses not prohibited by other provisions of the California Code of Regulations	Allowed	Not allowed	Not allowed	Not allowed
Food crops, surface-irrigated, above-ground edible portion, and not contacted by recycled water	Allowed	Allowed	Not allowed	Not allowed
Cemeteries	Allowed	Allowed	Allowed	Not allowed
Freeway landscaping	Allowed	Allowed	Allowed	Not allowed
Restricted-access golf courses	Allowed	Allowed	Allowed	Not allowed
Ornamental nursery stock and sod farms with unrestricted public access	Allowed	Allowed	Allowed	Not allowed
Pasture for milk animals for human consumption	Allowed	Allowed	Allowed	Not allowed
Nonedible vegetation with access control to prevent use as a park, playground or school yard	Allowed	Allowed	Allowed	Not allowed
Orchards with no contact between edible portion and recycled water	Allowed	Allowed	Allowed	Allowed
Vineyards with no contact between edible portion and recycled water	Allowed	Allowed	Allowed	Allowed
Non food-bearing trees, including Christmas trees not irrigated less than 14 days before harvest	Allowed	Allowed	Allowed	Allowed
Fodder and fiber crops and pasture for animals not producing milk for human consumption	Allowed	Allowed	Allowed	Allowed
Seed crops not eaten by humans	Allowed	Allowed	Allowed	Allowed
Food crops undergoing commercial pathogen-destroying processing before consumption by humans	Allowed	Allowed	Allowed	Allowed
Supply for impoundment:				
Nonrestricted recreational impoundments, with supplemental monitoring for pathogenic organisms	Allowed²	Not allowed	Not allowed	Not allowed
Restricted recreational impoundments and publicly accessible fish hatcheries	Allowed	Allowed	Not allowed	Not allowed
Landscape impoundments without decorative fountains	Allowed	Allowed	Allowed	Not allowed
Supply for cooling or air conditioning:				
Industrial or commercial cooling or air conditioning involving cooling tower, evaporative condenser, or spraying that creates a mist	Allowed³	Not allowed	Not allowed	Not allowed
Industrial or commercial cooling or air conditioning not involving cooling tower, evaporative condenser, or spraying that creates a mist	Allowed	Allowed	Allowed	Not allowed

Recycled Water Uses Allowed¹ in California

This summary is prepared for WateReuse Association from the December 2, 2000-adopted Title 22 Water Recycling Criteria and supersedes all earlier versions.

Use of Recycled Water	Treatment Level			
	Disinfected Tertiary Recycled Water	Disinfected Secondary-2.2 Recycled Water	Disinfected Secondary-23 Recycled Water	Undisinfected Secondary Recycled Water
Other uses:				
Groundwater Recharge	Allowed under special case-by-case permits by RWQCBs ⁴			
Flushing toilets and urinals	Allowed	Not allowed	Not allowed	Not allowed
Priming drain traps	Allowed	Not allowed	Not allowed	Not allowed
Industrial process water that may contact workers	Allowed	Not allowed	Not allowed	Not allowed
Structural fire fighting	Allowed	Not allowed	Not allowed	Not allowed
Decorative fountains	Allowed	Not allowed	Not allowed	Not allowed
Commercial laundries	Allowed	Not allowed	Not allowed	Not allowed
Consolidation of backfill material around potable water pipelines	Allowed	Not allowed	Not allowed	Not allowed
Artificial snow making for commercial outdoor uses	Allowed	Not allowed	Not allowed	Not allowed
Commercial car washes, not heating the water, excluding the general public from washing process	Allowed	Not allowed	Not allowed	Not allowed
Industrial process water that will not come into contact with workers	Allowed	Allowed	Allowed	Not allowed
Industrial boiler feed	Allowed	Allowed	Allowed	Not allowed
Nonstructural fire fighting	Allowed	Allowed	Allowed	Not allowed
Backfill consolidation around nonpotable piping	Allowed	Allowed	Allowed	Not allowed
Soil compaction	Allowed	Allowed	Allowed	Not allowed
Mixing concrete	Allowed	Allowed	Allowed	Not allowed
Dust control on roads and streets	Allowed	Allowed	Allowed	Not allowed
Cleaning roads, sidewalks and outdoor work areas	Allowed	Allowed	Allowed	Not allowed
Flushing sanitary sewers	Allowed	Allowed	Allowed	Allowed

¹ Refer to the full text of the December 2, 2000 version of Title 22: California Code of Regulations, Chapter 3 Water Recycling Criteria. This chart is only an informal summary of the uses allowed in this version.

The complete and final 12/02/2000 version of the adopted criteria can be downloaded from:
http://www.dhs.ca.gov/ps/ddwem/publications/Regulations/recycleregs_index.htm

² Allowed with "conventional tertiary treatment." Additional monitoring for two years or more is necessary with direct filtration.

³ Drift eliminators and/or biocides are required if public or employees can be exposed to mist.

⁴ Refer to Groundwater Recharge Guidelines, available from the California Department of Health Services.

Prepared by Bahman Sheikh and edited by EBMUD Office of Water Recycling, who acknowledge this is a summary and not the formal version of the regulations referenced above.

December 31, 2014

Technical Memorandum #4

To: Mike Prinz, Mike Sherman, and Colin Close – City of Santa Rosa

From: Rod Houser, PE, BCEE – Geysers Energy Audit Lead
Julia Lund – Deputy Project Manager
Alan Zelenka – Project Manager

Subject: Task 1.4 - Geysers Energy Audit
Santa Rosa Energy Optimization Plan (EOP) – Phase 1
K/J Project: 1368024*01

An energy audit and workshop was conducted by Kennedy/Jenks (KJ) at the Geysers Operations Center on April 16, 2014. The purpose of the audit was to identify and recommend cost-effective Energy Efficiency Measures (EEMs) for implementation by the City of Santa Rosa (Santa Rosa) to save energy and lower operating costs.

4. 1. Recommendation

Four EEMs were identified during the audit. After the analysis was conducted three EEMs were determined to be cost-effective and are recommended for implementation and are listed in Table 4-1 below. Cost-effectiveness is defined as an EEM that had a positive Net Present Value (NPV) from savings over the life of the EEM.

Table 4-1: List of Recommended Energy Efficiency Measures

EEM #	Category	Title
1	Process	Restore Pipeline Capacity
4	HVAC	Limit Operation of the Air-Handling Unit

A summary of the total costs, energy savings, and reductions in greenhouse gas emissions of these recommended EEMs is provided in Table 4-2.

Table 4-2: Summary of Recommended Energy Efficiency Measure Savings

Electricity Savings (kWh/Yr)	GHG Emission Reduction (MT/Yr)	Capital Cost (\$)	Incentive Amount (\$)	Net Cost (\$)	Avg Annual Net Savings (\$/Yr)	NPV of Avg Annual Net Savings (\$)
37,600	28	\$70,800	\$0	\$77,800	\$13,300	\$152,000

The priority order for implementation by Santa Rosa is based on the Return on Investment (ROI) for each recommended EEM. ROI is calculated using the Excel IRR function, but cannot be calculated if the capital cost is zero (a "NC" represents "not calculable"). Essentially, the ROI is infinite without capital costs; so EEMs with zero capital cost are therefore ranked based on the amount of NPV of cumulative net savings it brings to Santa Rosa. The recommended implementation order is in Table 4-3.

Table 4-3: Priority Implementation Order

Order	EEM#	Title	ROI (%)
1	4	Limit Operation of the Air-Handling Unit	NC
2	1	Restore Pipeline Capacity	18%

4. 2. Background

System Description

Santa Rosa owns and operates the Geysers System that consists of four medium-voltage pump stations and forty miles of pipeline. The System was designed to pump up to 40 million gallons per day (MGD) of tertiary effluent from the Laguna Treatment Plant (LTP) approximately 30 miles to Alexander Valley.

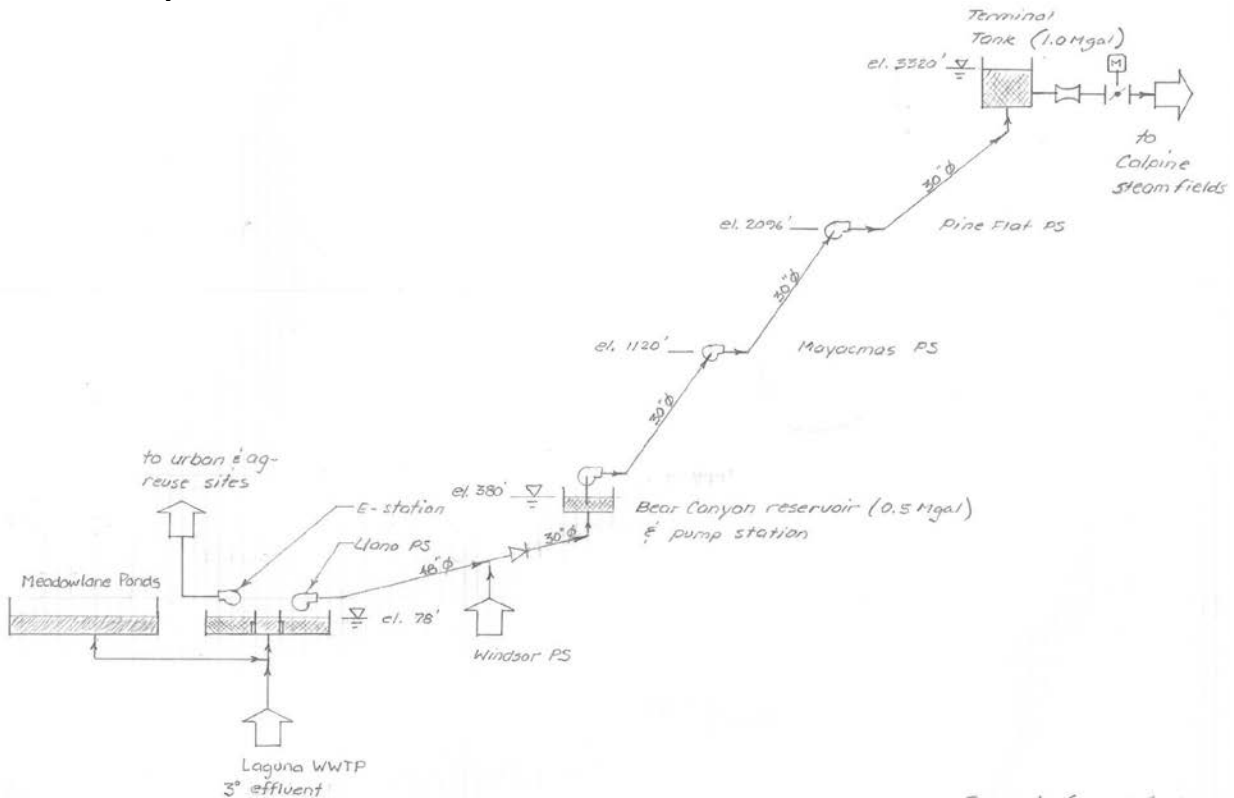

Figure 4-1: Geysers System Schematic

A turnout exists near Red Winery Road where up to 24 MGD of recycled water service could, in the future, be extended to vineyards in that region. The remaining 16 MGD can be conveyed to the 0.5 million gallon (Mgal) reservoir located at the Bear Canyon Pump Station. From there, three pump stations convey the recycled water through 3,000 feet of vertical lift to the 1.0 Mgal Terminal Tank. Calpine Corporation controls a flow-control station at the Terminal Tank where they regulate water deliveries to the injection wells located above the steam fields.

Midway between the first pump station (Llano) and Bear Canyon, the Town of Windsor injects between 0.2 – 0.7 MGD of tertiary effluent into the pipeline, where it blends with water from the LTP. Santa Rosa operates all of the pump stations; however, Calpine pays for the electricity to run the three North pump stations (Bear Canyon, Mayacmas and Pine Flat). The Town of Windsor pays for the electricity to run its pump station. For this reason, the scope of this study focused on pumping operations at Llano Pump Station and the pipeline that connects it to Bear Canyon Reservoir.

Energy Use and Cost

As part of the data collection prior to the onsite audit, Santa Rosa provided baseline energy usage for its Subregional System, including the Geysers System. The baseline provides a snapshot of how much energy is currently used at the existing Geysers System to allow for comparison to what impacts the various audit recommendations will have. The baseline energy profile for Geysers System includes electricity use, since natural gas usage is negligible.

KJ worked with Santa Rosa staff to collect the necessary data to create the baseline in a spreadsheet model entitled “Santa Rosa Energy Baseline.” Baseline data were developed using daily operating data from the Santa Rosa SCADA system and monthly billing data from PG&E for the period of January 2012 through December 2013.

For the Geysers System, the electricity baseline was broken down into Pumping and Miscellaneous categories, which respectively include data from SCADA and PG&E.

Table 4-4: Baseline Electricity Usage for Geysers System

Category	Baseline Annual Electricity Use (kWh/Yr)	Baseline Annual Electricity Cost (\$/Yr)
Geysers Pumping ¹	6,407,000	\$404,000
Miscellaneous (Building, Cathodic Protection) ²	74,000	\$8,200
Total Electricity Used for Geysers System	6,481,000	\$412,000

¹ Data are from Santa Rosa SCADA system from January 2012 to December 2013.

² Data are from Santa Rosa SCADA system and PG&E from January 2012 to December 2013.

As shown in Figure 4-2, the Geysers System uses close to 20% of the total electricity of the Subregional System.

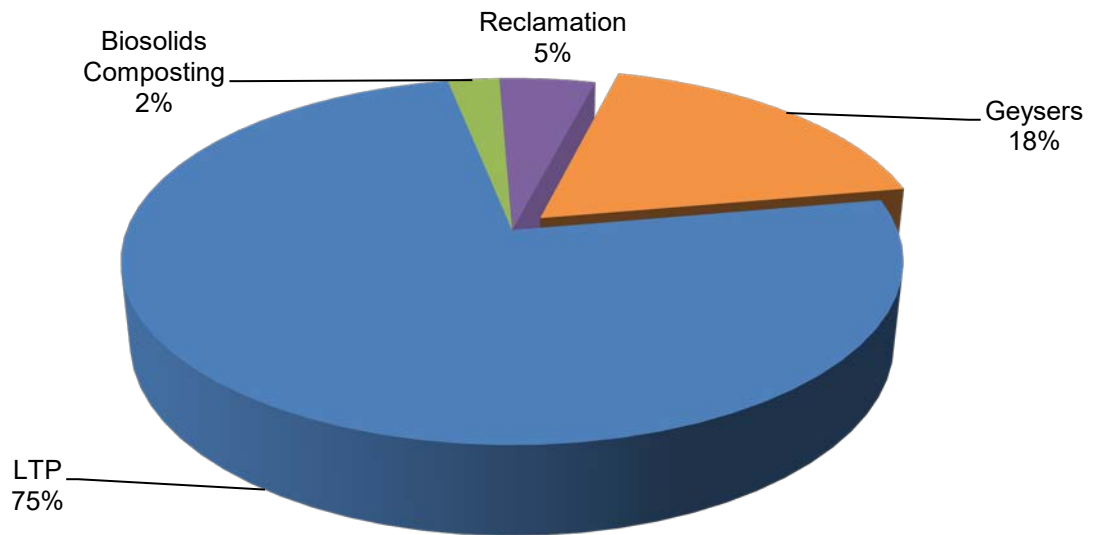

Figure 4-2: Annual Electricity Usage for Subregional System by Category

4. 3. Overview of Audit Methodology

KJ performed two different types of audits for the Geysers System: an equipment audit and a process audit. The equipment audit involved reviewing the major pieces of equipment at Llano Pump Station and assessing the cost-effectiveness and energy savings of changing the operation of the equipment, retrofitting the existing equipment, or replacing the existing equipment with a more energy efficient option. The audit systematically attempts to identify EEMs in several categories – building envelope, lighting, HVAC, and plug load. In addition to the main pump and pipeline performance characteristics, the following pump-station appurtenances were reviewed:

- Two 20 horsepower (HP) air compressors
- One 5 HP air-handling unit
- Building lighting

The process audit involved the review and evaluation of operational processes and procedures to identify changes that could lower costs and save energy.

Rod Houser of KJ conducted the energy audit and led a workshop with the Geysers Operations staff, which included the following participants: Mike Sherman, Tami Duval, Mike Pinoris, Daryl Clark, Andrew Klein, and Art Blass.

During the workshop four EEMs were identified for further analysis. For each EEM the auditor identified energy efficient replacement equipment or process change, assessed its cost-effectiveness, energy savings, GHG emission reductions, and identified operational impacts, and benefits as applicable. Actual electricity consumption data was used where available. If data were not available, working assumptions were made and used in this analysis. To determine the cost-effectiveness of the EEMs, capital cost, energy savings, PG&E incentives, net cost, average net annual cost/savings, and the net present value (NPV) of the average annual net savings were calculated.

Energy Efficiency Measures Analyzed

Building Envelope

Building envelope EEMs are associated with improving the energy efficiency of the windows (if any), weather-stripping around doors, and the insulation in the walls, ceiling and floor (if any). There is one concrete-masonry building at the Llano Pump Station that is approximately ten years old. The building has a metal standing-seam roof with no observable defects. There are no windows, and the building is usually unmanned (i.e., occupied less than 100 hours per year). No building envelope failures were identified, therefore no building envelope EEMs were identified for the Llano Pump Station building.

Lighting

Lighting EEMs save energy by installing controls or more efficient replacement lights. For the unmanned building at Llano Pump Station, no light-fixtures were identified for replacement due to the intermittent use of the building. The lights are normally left off unless some type of planned maintenance requires entry into the building space.

HVAC

HVAC EEMs save energy by replacing existing heating, ventilation and air conditioning equipment with more efficient equipment. For Llano Pump Station, HVAC consists of two roof-mounted exhaust fans and a five HP air-handling unit that forces fresh air into the building. There were no equipment replacement alternatives related to the HVAC system. However, one HVAC process improvement was identified; EEM-4: reduce operation of the air-handling unit.

Plug Load

Plug Loads address non-permanent office equipment like computers, copiers, and appliances. For Llano Pump Station, we recommend creating a policy of buying only Energy Star rated equipment.

Process

Process EEMs are changes to the operations at Llano Pump Station that result in energy savings. The following process EEMs were identified at Llano Pump Station:

- EEM-1: Restore Pipeline Capacity.
- EEM-2: Replace 800 HP Pump with 650 HP Pump.
- EEM-3: Change Pump-Control Logic.

A summary of the energy analysis is provided in Table 4-5, below. The EEMs highlighted in green are those that we found to be cost-effective, and are recommended for immediate implementation. A more detailed description of each EEM is provided in Section 4.

Table 4-5: Summary of Identified Energy Efficiency Measures

EEM No.	Category	Title	Energy Savings (kWh/Yr)	GHG Emission Reduction (MT/Yr)	Capital Cost (\$)	Incentive Amount (\$)	Net Cost (\$)	Avg-Annual Net Savings (\$/Yr)	NPV of Avg Annual Net Savings (\$)
1	Process	Restore pipeline capacity	109,000	22	\$70,800	\$0	\$70,800	\$9,200	\$104,600
2	Process	Replace 800-HP pump with more-efficient unit	7,765	2	\$910,800	\$620	\$910,800	-\$66,400	-\$976,000
3	Process	Modify pump-control logic	5,290	1	\$7,000	\$0	\$7,000	\$122	\$1,245
4	HVAC	Reduce operation of the air-handling unit	28,600	6	\$0	\$0	\$0	\$4,100	\$47,400
		Total of Recommended EEMs	37,600	28	\$70,800	\$0	\$77,800	\$13,300	\$152,000

4. 4. Detailed Descriptions of Recommended Energy Efficiency Measures

The following section describes the details of the recommended EEMs and provides financial summaries. All calculated numbers are based on rough order of magnitude estimates and parametric cost curves.

EEM-1: Restore Pipeline Capacity

Excessive head losses are occurring in the Geysers Pipeline, according to a report prepared in 2011¹. The report narrowed the location of excessive head loss to the 30-inch segment of HDPE pipe within two miles of Bear Canyon Reservoir. The approximate location is shown in Figure 4-3 below. Based on conversations with Geysers Operations staff, additional investigations are needed to more precisely locate the location of unusual head loss.

Camera access to the dewatered pipeline interior can be made through any one of several manways provided along the alignment. Access for maintenance activities of this nature would require careful planning and attention to confined-space safety precautions.

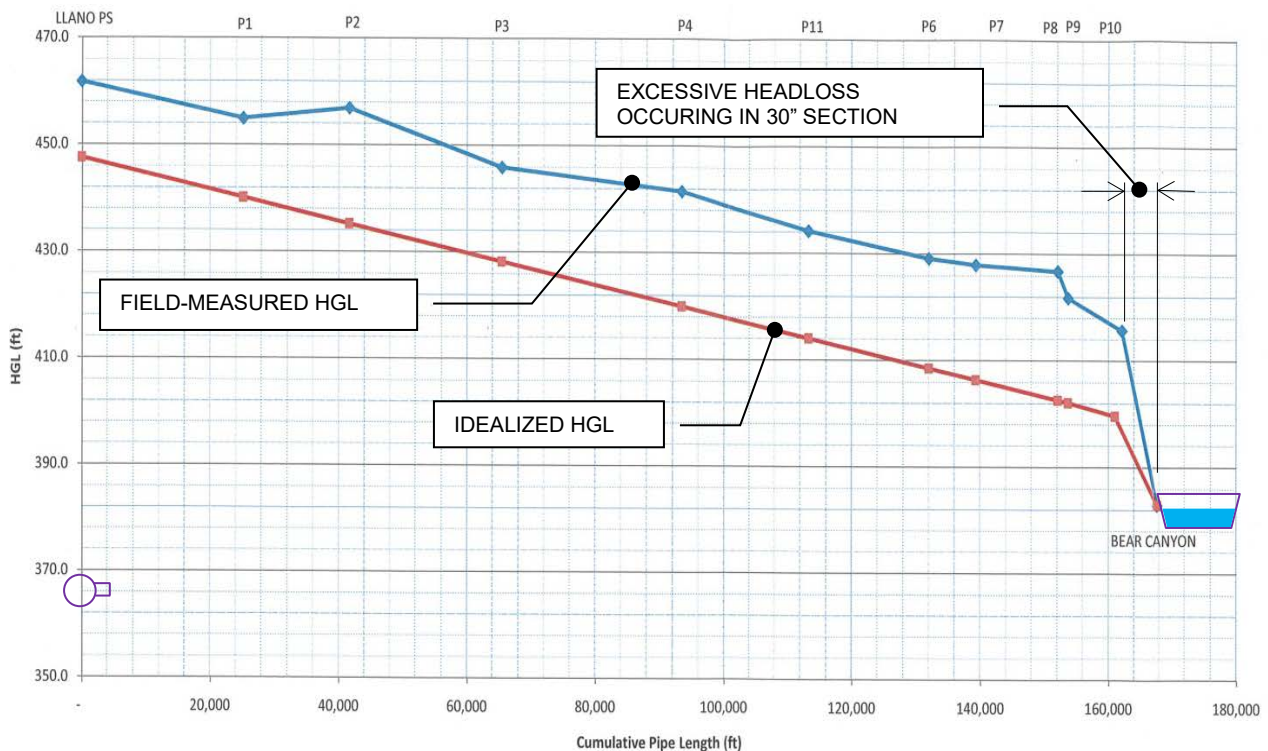

Figure 4-3: Hydraulic Profile

¹ Rocky Vogler, P.E., "Geysers Pipeline Hydraulic Testing", Winzler & Kelly Technical Memorandum, June 10, 2011.

Energy savings estimated for this EEM were taken from the Winzler & Kelly 2011 study.

Table 4-6: EEM-1 Restore Pipeline Capacity Summary

Electricity Savings (kWh/Yr)	Electricity Savings (\$/1st Yr)	GHG Emission Reduction (MT/Yr)	Capital Cost (\$)	Incentive Amount (\$)	Net Cost (\$)	Avg Annual Net Savings (\$/Yr)	NPV of Avg Annual Net Savings (\$)
109,000	\$11,700 ¹	22	\$70,800	\$0	\$70,800	\$9,200	\$104,600

EEM-4: Reduce Operation of the Air-Handling Unit (AHU) to Summer Months

The existing five HP AHU is designed to automatically turn on whenever one of the 1,250 HP pumps is operating. However, operations staff observed that the building maintains adequately low temperature to prevent overheating of the equipment unless ambient temperatures are very warm. This is most likely due to fans installed on the VFD cabinets, in addition to two roof-mounted exhaust fans that run continuously. One reason they turn it off in the winter is because the fan can suck rain into the building interior.

This EEM would require the AHU to be operated in HAND mode only during the warmest three months during the summer. The AHU would be turned off for the rest of the year when the other fans are adequate to ventilate the space.

A summary of capital cost and energy savings is provided in Table 4-8 below.

Table 4-8: EEM-4 Reduce Operation of the Air-Handling Unit Summary

Electricity Savings (kWh/Yr)	Electricity Savings (\$/1st Yr)	GHG Emission Reduction (MT/Yr)	Capital Cost (\$)	Incentive Amount (\$)	Net Cost (\$)	Avg Annual Net Savings (\$/Yr)	NPV of Avg Annual Net Savings (\$)
28,600	\$3,060	6	\$0	\$0	\$0	\$4,100	\$47,400

4. 5. Detailed Description of Energy Efficiency Measures Not Recommended

EEM-2: Replace Existing 800 HP Pump with More Efficient Unit

The four existing constant-speed 800 HP pumps are used to augment supply when demand at the Geysers exceeds maximum output of the 1,250 HP pump (about 13 MGD). When demand reaches 17 MGD (11,800 gallons per minute), the 1,250 HP unit delivers 6,400 gallons per minute at approximately 85% hydraulic efficiency. The 800 HP unit makes up the difference of 5,400 gpm and operates far to the right of the best-efficiency point (BEP), as shown in Figure 4-4. This is because

the pumps were originally designed to deliver up to 40 MGD (24 MGD to Alexander Valley plus 16 MGD to Geysers). In contrast, the current maximum contract delivery rate is 17.0 MGD, so the pumping head at this flow is significantly lower compared to what it would be at 40 MGD.

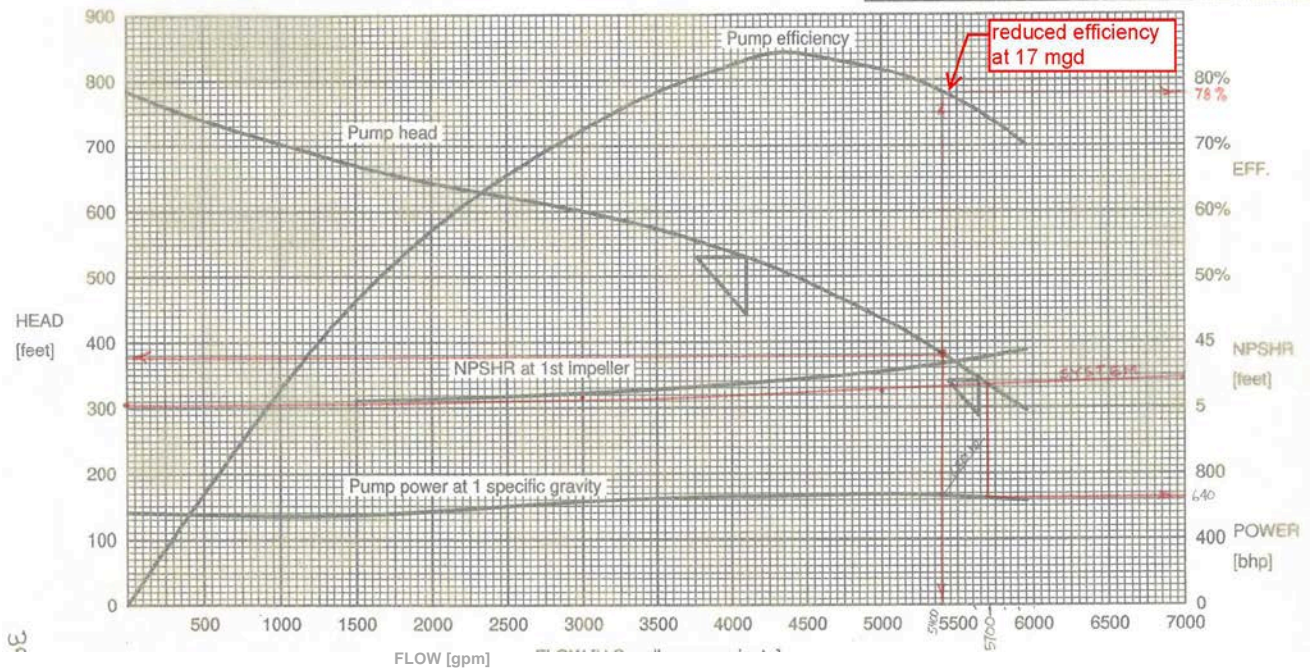

Figure 4-4: Performance Curve for Existing 800 HP Pump

This EEM would add a smaller pump (650 HP) that is hydraulically optimized to deliver 17 MGD when pumping in parallel with the existing 1,250 HP unit. If sized optimally, the pump could be expected to operate close to 85% efficiency while pumping in parallel with the larger unit (at a combined flow of 17 MGD), thereby reducing energy consumption.

A summary of energy savings and costs are provided in Table 4-9 below. An incentive of \$0.08/kWh for the first year of actual energy savings likely would be available through the basic non-lighting PG&E Customized Retrofit Incentive program:

<http://www.pge.com/en/mybusiness/save/rebates/ief/index.page>. Capital costs for this EEM far outweigh the meager electricity savings realized by improving the hydraulic efficiency; therefore, this EEM is not cost-effective and not recommended.

Table 4-9: EEM-2 Replace Existing 800 HP Pump Summary

Electricity Savings (kWh/Yr)	Electricity Savings (\$/1st Yr)	GHG Emission Reduction (MT/Yr)	Capital Cost (\$)	Incentive Amount (\$)	Net Cost (\$)	Avg Annual Net Savings (\$/Yr)	NPV of Avg Annual Net Savings (\$)
7,765	\$833	2	\$910,800	\$620	\$910,180	-\$66,400	-\$979,600

EEM-3: Optimize Pump-Control Logic

Currently, the first constant-speed pump (800 HP) is turned on when the 1,250 HP unit cannot keep up with demand. When the constant-speed pump starts, the 1,250 HP unit ramps down until pump station output matches demand. Hydraulic efficiency of the 800 HP unit is only 78% when operating together with the 1,250 HP unit, compared to 86% at its BEP.

This EEM would start the second 1,250 HP unit (instead of the 800 HP unit) when demand exceeds supply from a single 1,250 HP unit. Both 1,250 HP pumps would ramp up and down in unison to match demand. When operating in this mode, efficiency improves slightly.

A summary of energy savings and costs are provided in Table 4-7 below. The actual energy savings could be field measured using the customer-side metering provided at the pump station. This verification step should be completed to confirm the actual savings, before making any changes to the pump control logic. One advantage of this EEM is that it costs very little to implement since no new equipment is needed. However, the estimated cost savings is negligible and it would render the constant-speed pumps useless for normal deliveries.

Table 4-7: EEM-3 Optimize Pump-Control Logic Summary

Electricity Savings (kWh/Yr)	Electricity Savings (\$/1st Yr)	GHG Emission Reduction (MT/Yr)	Capital Cost (\$)	Incentive Amount (\$)	Net Cost (\$)	Avg Annual Net Savings (\$/Yr)	NPV of Avg Annual Net Savings (\$)
5,290	\$568	1	\$7,000	\$0	\$7,000	\$122	\$1,245

December 24, 2014

Technical Memorandum #5

To: Mike Prinz and Colin Close - City of Santa Rosa

From: Julia Lund - Kennedy/Jenks Deputy Project Manager
Alan Zelenka - Kennedy/Jenks Project Manager

Subject: Description of Brainstorming Workshop #1 Process and Outcomes – Draft TM #5
Santa Rosa Energy Optimization Plan
K/J 1368024*01

5.1 Background

Kennedy/Jenks (KJ) has been assisting the City of Santa Rosa Utilities Department (Santa Rosa) to develop the first phase of an Energy Optimization Plan (EOP) to serve as a master plan and road map to strategically and systematically optimize energy use, promote resource recovery, and provide leadership in environmental initiatives.

The work completed to date includes energy audits of four systems within Santa Rosa's Subregional System, including: 1.) Laguna Wastewater Treatment Plant (LTP), 2) Biosolids Compost Facility, 3) Recycled Water System, and 4) Geysers Recharge System.

The four energy audits identified 29 potential Energy Efficiency Measures (EEMs), and of these 20 EEMs were deemed to be cost-effective and were recommended. In addition, six Process Improvements (PIs) were identified for LTP. Inclusion of the replacement of the LTP Ultraviolet (UV) Disinfection System could also add substantially more benefit. Cumulatively, the benefits from the energy audits to Santa Rosa and are shown in Table 5-1 below.

Table 5-1: Cumulative Benefit of the Four Energy Audits

Benefit Metric	Cumulative Benefit from Identified EEMs	Including UV Disinfection Replacement
Electricity Savings (kWh/Yr)	3.4 Million	9.5 Million
Greenhouse Gas Emission Reductions (MMCO ₂ /Yr)	609	1,874
Net Capital Cost (\$)	\$349,000	\$12.8 Million
Average Annual Net Savings (\$/Yr)	\$427,000	\$551,000
Net Present Value of Cumulative Lifecycle of Savings (\$)	\$7.3 Million	\$8.5 Million

5.2 Workshop Objective

The EEMs and PIs identified during the energy audits represent a relatively comprehensive group of projects for each system, but the projects were narrowly focused on each individual system involving a small group of individuals with specific technical expertise. The objective of the Project Brainstorming Workshop (Workshop #1) was to involve a broader range of people and consider a larger, more holistic list of potential energy saving and GHG reducing projects for the Subregional System that were not already evaluated as part of the energy audits. Once the list was developed it would be narrowed to a short-list list of projects that would be assessed in detail as part of the next phase of the EOP.

5.3 Participants

The Workshop #1 participants included:

- Allen Balser (Santa Rosa, Acting Reclamation Superintendent)
- Colin Close (Santa Rosa, Research & Program Coordinator)
- Rip Forrey (Santa Rosa, Irrigation Program Coordinator)
- David Guhin (Santa Rosa, Director)
- Mike Prinz (Santa Rosa, Deputy Director of Subregional Operations)
- Terry Schimmel (Santa Rosa, Mechanical Superintendent)
- Joe Schwall (Santa Rosa, Wastewater Treatment Superintendent)
- Mike Sherman (Santa Rosa, Geysers Operations)
- Tasha Wright (Santa Rosa, Administrative Analyst)
- Rocky Vogler (Santa Rosa, Water Resources Planning)
- Julia Lund (Kennedy/Jenks, Deputy Project Manager)
- Alan Zelenka (Kennedy/Jenks, Project Manager)

Other Santa Rosa staff who were asked to provide input were: Edward Garcia (Utilities Technician), Zach Kay (Biosolids Coordinator), and Karl Righetti (Senior Wastewater Plant Operator).

5.4 Workshop Process Overview

Before Workshop #1, Santa Rosa staff was asked to develop a list of potential energy saving/generating and GHG reducing projects or programs in their area of responsibility for the Subregional System, drawing from other colleagues' input or other previous documents or studies. KJ staff also compiled potentially applicable projects using their expertise from previous projects. A total of 49 projects were identified.

On July 22, 2014, twelve Santa Rosa and KJ staff gathered for Workshop #1. After reviewing a summary of the four energy audits, the group reviewed the list of potential projects developed by Santa Rosa and KJ, asking clarifying questions as needed to ensure the concept of each project was understood. Some projects were removed from consideration since they were

already evaluated or implemented by Santa Rosa, while others were consolidated with other similar concepts.

Each participant then voted for the five projects they felt should be evaluated further, based on their own technical knowledge and personal perspective. The projects were scored and sorted on a spreadsheet from highest number of votes to lowest. The five projects with the most support became the short-list of projects, which will be evaluated further in the next phase of the EOP. Projects with insufficient support will not be evaluated further but could be evaluated in the future if circumstances change.

5.5 Project Scoring and Outcomes

Of the initial 49 projects proposed, 25 were either consolidated with other projects or removed from consideration since they have already been evaluated or implemented. The group voted on the remaining 24 projects. The scoring and sorting of the projects from highest number of votes to lowest is shown in Table 5-2.

The group came to a consensus that the top five projects were appropriate to evaluate in the next phase of the EOP. The group debated whether or not to include the projects on the cusp (specifically Projects #6, #7 and #8) but ultimately decided that none of them should be further evaluated at this time.

Table 5-2: Workshop #1 Scoring Results

#	Project Title	Total Votes	Votes w/o K/J	Notes
1	Waste Heat Investigation (including Organic Rankin Cycle)	8	7	
2	Pump Efficiency Software/Energy Management Software	8	6	
3	KJ and Power Hydrodynamics Collaboration/Pressure Dynamics of Irrigation System	7	6	
4	Comprehensive Solar Assessment (including Floatovoltaics)	6	5	
5	Install a Mechanical Digester Mixing System in Place of Existing Gas Injection Systems	6	6	
6	Wind	4	4	
7	Purchase a till-n-pak roller assist with planting see after sludge application/ no till drill	3	2	
8	Microturbines	3	3	
9	Biodiesel	2	2	
10	Landfill methane capture & generation	2	0	

#	Project Title	Total Votes	Votes w/o K/J	Notes
11	Microhydro projects	2	1	
12	Refrigerant leak detection	2	2	
13	Mello/Lafranconi (SCADA, PLC)	1	1	
14	Fleet fuel reductions	1	0	
15	Gridz storage	0	0	
16	C pond pump	0	0	
17	Install a 40 HP VFD air compressor in the digester gallery.	0	0	
18	Replace the compost facility's exhaust fans with high efficiency fans	0	0	
19	Replace several high HP pumps with more efficient options	0	0	
20	Replace existing desiccant air dryer for air compressor with new refrigerated air dryer	0	0	
21	Replace the two 50 ton air-cooled chillers and one 60 ton chiller that serve the HVAC equipment at the Administration building with single high efficiency water cooled chiller	0	0	
22	Absorption chillers	0	0	
23	Renewable energy credits (RECs) and other GHG reduction projects	0	0	
24	Sequestration from forestry, peat bogs, and wetlands projects	0	0	
25	LTP solar array	--	--	Consolidated with #4
26	Optimization of delta pump station	--	--	Removed (included in TM #3)
27	Solar panels at pump stations	--	--	Consolidated with #4
28	Run two Cummins engines on natural gas to generate electricity	--	--	Removed (included in TM #1)
29	Poncía/Terri-Linda (SCADA, PLC)	--	--	Removed (already evaluated)
30	Dei south (SCADA, PLC)	--	--	Removed (already evaluated)
31	Tomrose (SCADA, PLC)	--	--	Removed (already evaluated)
32	Delta #2 motor	--	--	Removed (included in TM #3)
33	North pump station reprogramming	--	--	Removed (already evaluated)
34	Install flow meter at Delta Pond pump station	--	--	Removed (included in TM #3)

#	Project Title	Total Votes	Votes w/o K/J	Notes
35	No till drill	--	--	Consolidated with #7
36	Program the SCADA system to divide the flow equally between the pumps whenever the flow requires more than one pump	--	--	Removed (included in TM #1)
37	Widen dead band between cooling and heating set points for compost facility offices	--	--	Removed (already implemented)
38	Install a solar PV system at LTP	--	--	Consolidated with #4
39	Purchase cleaner electricity from PG&E and/or another entity	--	--	Removed (already evaluated)
40	Clean energy purchases (including participation in Community Choice Aggregation program like Sonoma Clean Power Agency)	--	--	Removed (already evaluated)
41	Energy management software	--	--	Consolidated with #2
42	Fleet vehicle fuel-switching, no-idle policy, replacements and upgrades (e.g., hybrids, CNG, and biodiesel)	--	--	Consolidated with #14
43	FOG & Food-Waste-To-Energy	--	--	Removed (already evaluated)
44	Fuel cells	--	--	Removed (already evaluated)
45	GHG offsets	--	--	Consolidated with #23
46	Headquarters Building energy efficiency (e.g., HVAC, lighting, etc.)	--	--	Removed (already evaluated)
47	Joining a JPA or CCA	--	--	Removed (already evaluated)
48	Invest in renewable purchases	--	--	Consolidated with #23
49	Utility-scale wind	--	--	Consolidated with #6

5.6 Scope of Work for Short-Listed Projects

With consensus on the five short-listed projects, KJ asked Santa Rosa staff to further refine what specifically would be investigated for each project in Phase 2 of the EOP. The following are the refined scope of work items for each short-listed project.

5.6.1 Waste Heat Investigation

- A. Conduct a heat and use balance study for current conditions.
- B. Investigate options to take advantage of excess combined heat and power (CHP) heat generation, and identify alternative uses for the waste heat.
- C. Determine if an Organic Rankine cycle system is feasible and cost-effective.

- D. Determine the amount of waste heat generated by running idle Cummins engines on purchased natural gas to generate additional electricity (per TM #1 – LTP Energy Audit EEM-6).

5.6.2 Energy Management Software Investigation

- A. Determine the ability of the existing Subregional SCADA system to improve energy efficiency, operate the system to minimize energy use, and take advantage of Time-Of-Use rates.
- B. Identify strategies to increase energy efficiency gains (e.g., optimizing for Time-Of-Use rates, identify pumps/motors for First-On-First-Off strategy, and pump optimization).
- C. Identify SCADA programming needs to take advantage of identified strategies.
- D. Identify cost-effective and necessary additional instrumentation of equipment needed to implement the identified strategies and integrate with the SCADA system, and estimate their capital cost.
- E. For the above subtasks, specifically discuss impacts on the operational constraints and on the plant process stability. The decision to pursue any strategy will be the sole purview of Santa Rosa.

5.6.3 Irrigation System Optimization Investigation

- A. Analyze existing pressure needs and compare them to current operational practices.
- B. Identify what measures, either equipment and/or operational practice changes, would be cost-effective and beneficial for Santa Rosa.
- C. For City cost-effective measures, estimate if they are cost-effective for the agriculture sector customers.
- D. Work with Santa Rosa staff to identify which irrigation fields and pumps should be tested by Power Hydrodynamics through a separate contract managed by Santa Rosa. For this subtask we are assuming that the Delta Pond pump station and Meadow Lane pump stations will be tested by Power Hydrodynamics (up to 12 pumps). Once the test results are received from Power Hydrodynamics, use KJ's Cost/Savings Template to calculate the cost-effectiveness and estimate the energy savings of each pump tested.

5.6.4 Comprehensive Solar PV Investigation

- A. Perform an assessment of flotovoltaics as a new solar PV technology and assess the work already done by the County.
- B. Conduct a comprehensive site evaluation study of Santa Rosa-owned sites, prioritize potential sites, and identify three top sites.
- C. For the top three sites, determine the cost-effectiveness of solar PV projects using three financing options: Power Purchase Agreement, lease-buyout, and own and operate.
- D. Assess the existing solar PV systems (e.g., Alpha Farm 21 kW, Brown Farm 60 kW, LTP 21 kW, LTP roof 50 kW), and investigate potential cost-effectiveness enhancements to

performance, specifically address moving the inverter at the Alpha control building that is currently creating surplus heat.

- E. Analyze the interaction and impacts of new Santa Rosa solar PV projects with potential participation by Santa Rosa in Sonoma Clean Power (SCP), specifically looking at net metering, disposition of excess generation, rates, and costs/benefits.

5.6.5 Mechanical Digester Mixing

- A. Summarize the existing KJ analysis and design from 2006 for mechanical digester mixing and assess if there are any changes that could further optimize the design.
- B. Identify and assess other options, and make a recommendation on the preferred approach for Santa Rosa.
- C. Conduct a high level cost estimate for the preferred approach.
- D. Estimate the amount of new digester gas production from the mechanical mixing, estimate the change in energy produced and cost from additional mechanical digester mixing compared to only the existing gas mixing system, estimate the value of additional electricity generated using the existing CHP system, and conduct a cost/benefit analysis. For this analysis, use both SCP and PG&E rates with (SCP rates being 3% to 5% lower).
- E. Using the analysis for the newly designed high strength waste (HSW) and fats, oils and grease (FOG) system; analyze and estimate the incremental digester gas production attributable to the recommended digester mixing approach.

May 19, 2017

Final Technical Memorandum #6

To: Mike Prinz, Joe Schwall, Tasha Wright, and Claire Myers - City of Santa Rosa
 From: Zachary Harris, Waste Heat Investigation Lead
 Alan Zelenka, Kennedy/Jenks Project Manager
 Subject: Task 2.1 - Laguna Wastewater Treatment Plant Waste Heat Investigation
 K/J 1369024*02 - Santa Rosa Energy Optimization Plan, Phase 2

The purpose of this Technical Memorandum is to conduct a waste heat and use balance study for the combined heat and power plant (CHP or cogeneration facility) at the Laguna Wastewater Treatment Plant (LTP). In addition, Kennedy/Jenks investigated options to take advantage of excess waste heat from the additional operations of a third cogeneration unit, and determine if an Organic Rankine Cycle (ORC) system is feasible and cost-effective.

6.1 Recommendations Summary

K/J prepared a Process Energy Audit of the LTP under Task 1.1 of the Energy Optimization Plan, Phase 1 (Technical Memorandum #1, or TM1) in December, 2014. Among the energy efficiency measures (EEM's) identified in TM1 was EEM-6, the running of idle Cummins cogeneration units on natural gas to generate electricity. TM5 – Brainstorming Workshop, also prepared in December 2014 identified the use of waste heat from the cogeneration units as a potential energy efficiency measure and requested further investigation of options for the use of waste heat from the cogeneration units.

This memorandum reviewed four alternatives for using excess waste heat, and developed one recommended EEM from this investigation: EEM 6-1 *Two ORC Generator Units* at LTP using the surplus waste heat created by bringing on line Cogeneration Unit #3. A summary of the recommended EEM utilizing waste heat is shown in Table 6-1.

Table 6-1: List of Recommended EEM

EEM#	Title
EEM 6-1	Two ORC Generator Units (100 kW)

Since two ORC generators, generating 50 kW each, from recovered waste heat from the additional full-time operation of Cogeneration Unit #3 appears to be cost-effective, Kennedy/Jenks recommends EEM 6-1 be studied in greater detail. This analysis shows that the total capital cost of an ORC project (i.e., two ORC generator units) would be approximately \$975,000. This would generate an additional 100 kW and 745,000 kWh/Yr of electricity, would provide a rate of return on the investment of 6.0%, create an average annual net savings of

Memorandum

Santa Rosa EOP – Task 2.1 Waste Heat Investigation

Page 2

\$17,700, and a Net Present Value (NPV) of cumulative lifetime net savings of \$213,000 (including a Self Generation Incentive Program (SGIP) amount of \$107,000). Without the SGIP incentive the NPV drops by 50% to a little over \$105,000 and the rate of return drops to 4.9%. A summary of the savings from the EEM-1 for both scenarios is provided in Table 6-2, below.

Table 6-2: Summary of Recommended EEM

Incentive	Electricity Savings (kWh/Yr)	Capital Cost (\$)	Avg Annual Net Savings (\$/Yr)	NPV of Cumulative Net Savings (\$)	ROR (%)
With SGIP	744,600	\$975,000	\$17,700	\$213,000	6.0%
Without SGIP	744,600	\$975,000	\$11,000	\$105,000	4.9%

6.2 Existing System Summary

In 2010, the City of Santa Rosa upgraded the cogeneration facility at the Laguna Wastewater Treatment Plant, installing four 1,100 kW Cummins gas-fired internal combustion engine-generator units to provide power for LTP operations. One unit was placed in operation at the time of installation. A second unit was recently placed into operation in June, 2016. These units, in full-time operation, utilize a combination of digester gas from the wastewater treatment process and natural gas supplied from PG&E. The two remaining units sit idle. It should be noted that the City's upcoming microgrid project would support a third engine being brought online.

Santa Rosa is interested in operating one of the idle cogeneration units using natural gas from PG&E to generate electricity and reduce electricity purchases from PG&E; this was recommended in Tech Memo #1 – LTP Energy Audit.

The operation of an engine-generator produces waste heat through three heat transfer systems:

1. The transfer of heat from the engine to the jacket water coolant system, which is typically expelled through an air-cooled radiator.
2. The transfer of heat through the engine exhaust, which is typically radiated to the environment.
3. The transfer of heat from the engine's lube oil system, which is typically expelled through an air-cooled radiator.

Memorandum

Santa Rosa EOP – Task 2.1 Waste Heat Investigation

Page 3

Santa Rosa's engine-generator installations utilize the waste heat from the engines in a more efficient manner:

- A high-temperature circulating water system (the jacket water circuit) collects waste heat from the first two systems described above. The jacket water circuit transfers energy to a secondary water loop which uses the energy to heat the digested sludge. The jacket water circuit then discharges the remainder to a secondary waste cooling water circuit.
- A lower temperature circulating water (the auxiliary water circuit) collects waste heat from the third system. The auxiliary water circuit discharges all of the energy transferred from the lube oil system to a secondary waste cooling water circuit.

Operation of two engine-generators provides sufficient waste heat for all of the sludge heating demands for LTP. There is almost always some excess waste heat generated during this process, though less during winter months.

The engine-generator has two cooling water circuits: a low-temperature circuit for cooling the aftercooler system, and a high temperature circuit for cooling the engine.

The jacket water circuit draws waste heat from two locations:

- The engine (Q_{1in}).
- A secondary heat exchanger at the engine exhaust (Q_{2in}).

A breakdown of how the natural gas fuel input is distributed as energy output per cogeneration unit is shown in Table 6-3 below.

Table 6-3: Energy Inputs and Waste Heat Available¹

Facility	Annual Natural Gas Input (MMBtu/Yr)	Annual Electricity Generation (kWh/Yr)	Annual Waste Heat Jacket Water Circuit (MMBtu/Yr)	Annual Waste Heat Other Systems ¹ (MMBtu/Yr)
Cogeneration Unit #3	80,500	9,636,000 (33,900 MMBtu/yr equivalent)	35,900	10,700

¹ Includes waste heat discharged to aftercooler circuit, heat radiated from engine, and energy from unburned fuel.

As shown in Table 6-3, there is a significant amount of waste energy available from the jacket water circuit. The waste heat from the jacket water circuit is 35,900 MMBtu/Year or 4.1 MMBtu/Hour. This is approximately 45% of the input energy from the natural gas fuel source. If the energy from the waste heat can be converted to useful energy in any manner, the overall value of the CHP project could be enhanced.

¹ See highlighted information from Cummins QSK 60 engine data sheet in Appendix A of this report. Supplemental calculations to show the annual totals are included

Memorandum
 Santa Rosa EOP – Task 2.1 Waste Heat Investigation
 Page 4

A schematic of the high temperature (jacket water) circuit is shown in Figure 6-1, below.

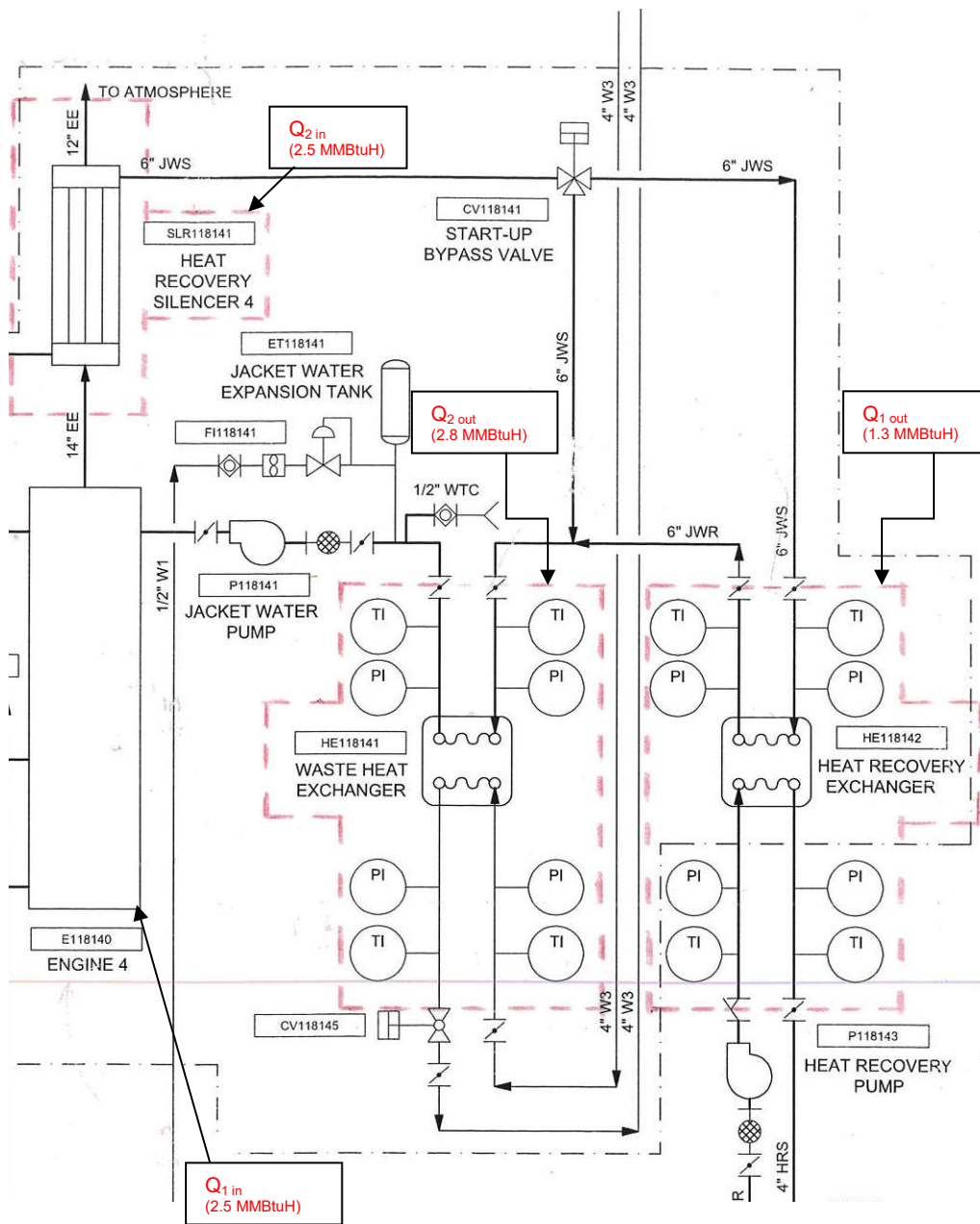

Figure 6-1: Existing High Temperature (Jacket Water) Cooling Circuit

Memorandum

Santa Rosa EOP – Task 2.1 Waste Heat Investigation

Page 5

6.2.1 Existing Evaporative Cooling Units

Under full-load operation, the heat radiated from each engine is 580,000 Btu/Hour (48.3 tons) for a total of 1.16 MMBtu/Hour (97 tons) for the two operating cogeneration units. Evaporative Cooling units were installed as part of the 2010 cogeneration facility renovation to provide cooling for the cogeneration project. The two evaporative cooling units installed at the cogeneration facility have a design output capacity of 870,000 Btu/Hour (72.5 tons) each, for a total of 1.74 MMBtu/Hour (145 tons) – more than sufficient to handle two engines. Each evaporative cooling unit contains two 20 HP supply fans, that incorporate variable speed drives; with a clean filter the running load from each fan is estimated to be 12 HP.

One consequence of putting a third cogeneration unit on-line is that it will radiate additional waste heat into the space – an additional 580,000 Btu/Hour (48.3 tons). However, City staff has concluded that this will not require additional cooling to maintain operations at design efficiency and maintain a safe temperature for employees.

6.3 Waste Heat Recovery Options

The energy available from the jacket water circuit can be used in three different systems:

- Secondary heating systems - either through a liquid-to-liquid heat exchanger or an air column passing over a hot water heating coil.
- Cooling systems - using an absorption chiller to generate chilled water, this can then be transferred to other systems through a heat exchanger or a chilled water cooling coil.
- Organic Rankine Cycle electricity generation systems.

The best application for any of these systems would be where it could be continually applied in order to match the continual operation of the cogeneration project. Keeping the uses of the waste heat close to the cogeneration building will minimize the cost of the projects by limiting the need for additional long piping loops.

Since the sludge heating needs are already being met through the operation of Cogeneration Units #1 and #2, there is no need for additional sludge heating from the waste heat of Cogeneration Unit #3.

6.4 Recommended Energy Efficiency Measure

This investigation evaluated two EEMs:

- EEM 6-1: Two ORC Generator Units
- EEM 6-2: Large Replacement Absorption Chiller

Memorandum

Santa Rosa EOP – Task 2.1 Waste Heat Investigation

Page 6

EEM 6-1 was found to be cost-effective and is therefore recommended for further investigation and is discussed below. EEM 6-2 was not found to be cost-effective, and is discussed in Section 6.6, Not Recommended Energy Efficiency Measures.

6.4.1 EEM 6-1: Two Organic Rankine Cycle Generator Units

The most valuable use of the waste energy would be to generate additional electricity. The electricity generated could be put to use, either within LTP or sold to PG&E, with minimal infrastructure additions.

An ORC power generation system is a thermodynamic cycle which converts heat into work. The working principle of an ORC is that the working fluid is pumped to a boiler where it is vaporized by the heat from the waste heat source, where it is then fed to a turbine generator where electricity is created, and then passed through a condenser where it is finally re-condensed. The working fluid in an ORC is a refrigerant, an organic chemical such as HFC R-245fa, which is used instead of water because of its lower boiling point. This allows a lower temperature heat source, such as waste heat, to be utilized. A diagram of a typical ORC system is shown in Figure 6-2, below.

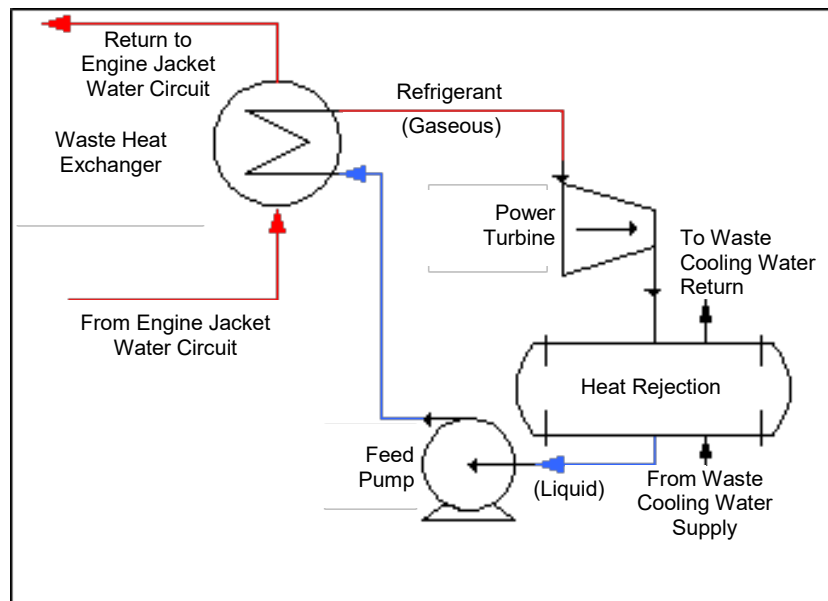

Figure 6-2: Organic Rankine Cycle System Schematic

ORC systems are a relatively new technology. ORC was invented in the 1960s but is only now becoming commercially available. There are installations in Europe and Japan, but installations in the US are limited. Moving forward with implementation of an ORC would make Santa Rosa an early adopter of this technology.

Memorandum

Santa Rosa EOP – Task 2.1 Waste Heat Investigation

Page 7

There are two manufactures of ORC systems that can utilize the 4.1 MMBtu/Hour of thermal energy available for this project:

- **Infinity Turbine LLC, Madison WI:**

The available systems have nominal output ratings of 10, 50, and 250 kW. The model IT50 system can produce a 55 kW output under a design jacket water flow rate of 110 gpm, and a 35 degree delta-T with 60 F cooling water. The cooling water temperature has been measured at 80 F. The higher cooling water temperature will result in a minor drop-off in ORC unit performance. To be conservative, the analysis was performed with a reduced 50 kW output. Two IT50 units can be set-up in parallel configuration to produce a 100 kW output (745,000 kWh/year). www.infinityturbine.com



Figure 6-3: Infinity Turbine ORC

- **ElectraTherm, Reno, NV:**

The available systems have nominal output ratings of 35, 65 and 110 kW. The 65 kW system (model 4400) can produce a 35 kW output under a design flow rate of 130 gpm. Two units can be set-up in parallel configuration. The 110 kW system (model 6500) can only produce a 50 kW output under a design flow rate of 260 gpm. www.electratherm.com

Given the higher kW output at similar flow rates, the preferred option is two Infinity Turbine IT50 ORC generator installations as a means of waste heat recovery from the full-time operation of Cogeneration Unit #3. The jacket water circuit would be divided into two circuits with each delivering hot water to one ORC generator. The maximum design flow rate of the Infinity Turbine IT50 ORC generator is 118 gpm, and two ORC generators would use 236 gpm which is less than

Memorandum

Santa Rosa EOP – Task 2.1 Waste Heat Investigation

Page 8

the available 260 gpm flow rate of waste heat. The ORC system's installation location would need to be determined.

The capital cost for each ORC unit is approximately \$200,000 each (price quote from Infinity Turbines). Engineering cost is 25% of total project cost, installation is 30% of equipment costs, site work and connections and electric work is another 50% of equipment costs, and permits administration and legal cost is another 15% of equipment cost. Total capital cost for two ORC units installed is \$975,000.

Table 6-4: EEM-1 Capital Cost Breakdown

Amount (\$)	Capital Item	%	
\$400,000	Total Equipment Cost (2 at \$200,000)		
\$195,000	Engineering	25%	% of Project Costs
\$120,000	Installation	30%	% of Equip Cost
\$200,000	Site Work/Connections/Electrical	50%	% of Equip Cost
\$60,000	Permit/Admin/Legal	15%	% of Equip Cost
\$975,000	TOTAL Capital Cost		

The O&M costs would be 0.2 FTE, or 8 hours per week, plus a half a cent per kWh (\$0.005/kWh). There is also a cost to provide the cooling water needed for ORC unit operation. The condenser water flow rate will be slightly more than the jacket water flow rate of 236 gpm (118 gpm per ORC unit). For this analysis, a flow rate of 300 gpm for the two ORC units provided for each cogeneration unit is assumed. The recycled cooling water is to be returned to the Plant for re-treatment. The cost for re-treatment will be \$14,230/yr and has been incorporated into the cost analysis as an annual O&M cost.

An incentive for the ORCs through the PG&E Self Generation Incentive Program (SGIP) may be available, but to-date no ORC system has received approval. The amount of the incentive is calculated by multiplying the installed kW by the Waste Heat to Power rate of \$1,070/kW (e.g., 100 kW x \$1,070/kW = \$107,000). Half of the SGIP incentive is paid up front and the remaining half is paid out over five years. Given the uncertainty of the SGIP incentive results are given for the EEM with and without the SGIP incentive amount.

The ORC project is expected to provide an average annual net savings of nearly \$18,000 with the SGIP incentive and \$11,000 without; with a NPV of the cumulative net savings of \$213,000 with the SGIP incentive over the 20-year life the ORC generators, and \$105,000 without. The return on investment is 6% with the SGIP incentive and almost 5% without.

Memorandum

Santa Rosa EOP – Task 2.1 Waste Heat Investigation

Page 9

Table 6-5: EEM 6-1 Organic Rankine Cycle Summary

Incentive	Electricity Savings (kWh/Yr)	Electricity Savings (\$/1 st Yr)	Capital Cost (\$)	Incentive Amount (\$) ¹	Cumulative Net Savings (\$)	Avg Annual Net Savings (\$/Yr)	NPV of Cumulative Net Savings (\$)	ROR (%)	GHG Emission Reduction (MT/Yr)	Cumulative GHG Reductions (MT)
With SGIP	744,600	\$88,000	\$975,000	\$107,000	\$355,000	\$17,700	\$213,000	6.0%	76	1,513
Without SGIP	744,600	\$88,000	\$975,000	\$0	\$222,000	\$11,000	\$105,000	4.9%	76	1,513

¹ In the Cost-Effectiveness Spreadsheet for EEM-1, one can turn off the SGIP incentive by choosing “none” in the dropdown menu in cell G22.

6.5 Energy Efficiency Measures Recommended for Further Investigation

6.5.1 EEM 6-4: Lystek Process

The Lystek™ process is a low-temperature Thermal Hydrolysis Process for handling of biosolids and organic material developed by Lystek International (Cambridge, Ontario, Canada). The Lystek™ process takes place within an enclosed reactor vessel and incorporates a cutting system along with the application of low-temperature steam to transform biosolids material into a liquefied product that can be distributed, or sold, as LysteGro™, a fertilizer licensed under the California Department of Food and Agriculture, and meeting EPA’s standards for Class A EQ fertilizer.

The Lystek process can also be configured to produce products that can be re-introduced into the wastewater treatment process: LysteCarb™, an alternative to methanol or glycerol as an aid for Biological Nutrient Removal (BNR); or LysteMize™, a digester re-feed enhancement to increase gas production and reduce biosolids volume.

The process has been implemented at the Organic Material Recovery Center of the Fairfield-Suisun Sewer District (FSSD), in a facility that was brought on-line in October 2016. The process, constructed, operated, and maintained by Lystek International, will convert the 12,000 tons/yr of biosolids processed at the Recovery Center to the LysteGro™ product for sale to area farmers. Lystek International has also contracted with Central Marin Sanitation Agency for the processing of its biosolids output, 6,500 tons/yr, to produce LysteGro™ at the FSSD Recovery Center. At this time, information on the capital and operating costs of the system are not available.

For the City of Santa Rosa, the waste heat from the cogeneration process at LTP can be used as a heating source to produce steam for the Lystek process. The Lystek™ process could be used to produce the LysteGro™ product from the biosolids material produced at the Laguna Compost Facility.

Memorandum

Santa Rosa EOP – Task 2.1 Waste Heat Investigation
Page 10

6.6 Not Recommended Energy Efficiency Measures

6.6.1 EEM 6-2: Large Replacement Absorption Chiller

Kennedy/Jenks also analyzed if using one large 200-ton absorption chiller unit would be cost-effective, replacing the existing evaporative coolers and forgoing the ORC generator installation.

An absorption chiller operating from the waste heat of the Cogeneration Unit #3 could have a cooling output that matches what is provided from the two evaporative coolers. The 260 gpm jacket water flow and 20-degree delta-T available from the jacket water system can provide the thermal energy for an absorption chiller unit of up to 200-ton capacity, enough to account for the entirety of the facility's cooling needs.

The use of this absorption chiller would require separate air handling units (i.e., two at 30,000 cfm capacity), and a chilled water pump to circulate chilled water between the absorption chiller and the air handler. This system would provide a net energy savings because the total electrical consumption for the 200-ton absorption chiller system with the two 50 HP air handlers would be 42 kW, which is 18 kW less than the combined 60 kW for the 80 HP evaporative cooling system fans.

The capital cost of the absorption chiller system is approximately \$528,000 (\$240,000 for a new absorption chiller, \$140,000 for two handlers, \$60,000 for equipment installation, and \$88,000 for engineering). These costs are compared to the zero (\$0) additional capital cost of the already installed evaporative cooling systems.

Energy savings through the operation of the absorption chiller are about 126,000 kWh. In addition, there will be an incentive through the PG&E Customized Incentive Program. The amount of the rebate is calculated by multiplying the annual energy savings by \$0.15/kWh (e.g., 126,000 kWh x \$0.15/kWh = \$18,900).

The table below shows that installing an absorption chiller would create energy savings but it won't be enough to overcome its high capital costs. An absorption chiller would result in an average annual net **COST** to Santa Rosa, making the retention of the existing evaporative cooler system a more cost-effective option.

Table 6-6: EEM 6-3 Large Absorption Chiller Summary

Electricity Savings (kWh/Yr)	Electricity Savings (\$/1 st Yr)	Capital Cost (\$)	Incentive Amount (\$)	Avg Annual Net Savings (\$/Yr)	Cumulative Net Savings (\$)	NPV of Cumulative Net Savings (\$)	ROR (%)	GHG Emission Reduction (MT/Yr)	Cumulative GHG Reductions (MT)
126,100	\$14,900	\$528,000	\$18,900	(\$15,500)	(\$311,700)	(\$242,500)	-1.1%	13	256

Memorandum

Santa Rosa EOP – Task 2.1 Waste Heat Investigation

Page 11

6.6.2 Additional Rejected Uses of Waste Heat

The following uses of the waste heat were analyzed and rejected for the following reasons:

1. **Sludge heating** – Since all LTP heating needs are already being met through the operation of Cogeneration Units #1 and #2, there is no need for additional sludge heating from the waste heat of Cogeneration Unit #3.
2. **Digester gas cooling** - The digester gas cooling system uses a 10-ton scroll (refrigerant-based) chiller. The chiller is located near the digester. The 10-ton absorption chiller described in the previous section could be used as a replacement source for producing chilled water, but the installation would require a chilled water piping loop between the cogeneration facility and the digester area. The shortest identified piping route was approximately 600 linear feet (LF). The absorption chiller would create a net energy savings, but the capital costs to install a 600 LF buried pre-insulated piping system (supply and return) will negate the lifetime energy savings.
3. **Use of the waste heat by a near-by business** – Because of heat loss, even with an insulated pipe, transferring heat over long distances is usually not cost-effective. So while this may be technically feasible, given the remoteness of LTP there are few appropriate near-by businesses that might use the waste heat. However, LTP may consider investigating further the use of waste heat onsite by the compost facility or for sludge dewatering.
4. **Establish or promote the creation of a new near-by business that could use the waste heat** – The complexity of doing this combined with the remoteness of LTP and the relatively small amount of available waste heat caused us to reject this option.

June 1, 2017

FINAL Technical Memorandum #7

To: Mike Prinz, Tasha Wright, and Claire Myers, City of Santa Rosa

From: Nick Peros, Energy Management Software Investigation Lead
Alan Zelenka, Kennedy/Jenks Project Manager

Subject: Task 2.2 - Energy Management Software Investigation
K/J 1369024*02

The purpose of this Technical Memorandum is to:

- describe the ability of the existing Subregional Supervisory Control and Data Acquisition (SCADA) system to improve energy efficiency, operate the system to minimize energy use, and take advantage of Time-Of-Use (TOU) rates¹;
- identify strategies to increase energy efficiency gains;
- identify SCADA programming needs to take advantage of identified strategies;
- identify cost-effective and necessary additional instrumentation of equipment needed to implement the identified strategies and integrate with the SCADA system, and estimate their capital cost; and
- discuss impacts on the operational constraints and on the plant process stability.

The decision to pursue any strategy will be the sole purview of Santa Rosa.

7.1 Recommendation Summary

Kennedy/Jenks reviewed several potential energy efficiency measures (EEM) and process improvements (PI); however, after closer investigation Kennedy/Jenks recommends only one EEM (EEM 7-1: *Modify Pump Alternation at Laguna Treatment Plant*) and one PI (PI 7-1: *SCADA Screens and Instruments to Facilitate Energy Management*).

EEM 7-1 involves changing the operational protocol for using pumps. Instead of equalizing run-time of all the pumps within a system, operations would run the most efficient pumps to minimize energy use. Applying this recommended protocol to Influent, Return Activated Sludge (RAS), and Waste Activated Sludge (WAS) pumps will yield savings to Santa Rosa. The average annual savings is about \$16,700, the Net Present Value (NPV) of the cumulative net savings is \$235,000, and the Rate of Return on the nearly \$30,000 investment is 67% as shown in Table 7-1.

¹ TOU rates charge a higher rate when electric demand is higher, instead of a single flat rate for energy use. For additional information on TOU rates see Section 7.6.1, PI 7-2: Monitor TOU Rate Changes.

Technical Memorandum

Santa Rosa EOP – Task 2.2 Energy Management Software Investigation

Page 2

Table 7-1: Summary of Recommended EEM 7-1

Electricity Savings (kWh/Yr)	Capital Cost (\$)	Incentive Amount (\$)	Avg Annual Net Savings (\$/Yr)	NPV of Cumulative Net Savings (\$)	ROR (%)
150,800	\$29,800	\$12,000	\$16,700	\$235,000	67%

PI 7-1 would provide operators a more complete picture of real time and historical energy usage at LTP. This information will help identify additional opportunities for process improvement, increased energy savings, and alert operators to possible adverse trends.

7.2 Existing System Summary

On June 23, 2015, Nick Peros visited Laguna Treatment Plant (LTP) and met with Terry Schimmel, Utilities Mechanical Superintendent, and Bob Arthur, Senior Instrumentation Technician. Terry and Bob communicated the following information:

- Santa Rosa's SCADA system is running a mix of recent vintages of Wonderware, System Platform 2012 R2 and 2014.
- Server software runs with Historian redundancy on dual Dell PowerEdge R310 servers; one second tier Historian, used for business reporting, is located downtown and runs on an unknown hardware.
- A transition to virtual machines and ArcestrA graphics is in progress and is scheduled for completion by year's end. The hosts are dual-redundant Dell PowerEdge R320 servers with 32 gigabytes (GB) of random access memory (RAM.) The storage area networks (SANs) are dual-redundant Synology units which are connected to the hosts via one gigabit (Gb) copper Ethernet connection. After the transition to virtual machines is complete the plan is to re-purpose the R310s as additional hosts, for a total of four.
- Domain security is not implemented for the present SCADA network.
- Plant networking is 100 Mb using multimode fiber with a non-redundant topology.
- Consistent with best practices, logic for running treatment processes is only in the programmable logic controllers (PLCs) or via electro-mechanical controls, e.g., in the motor control centers (MCCs) and not in the SCADA system.
- With one exception (Bins), only local touchscreens are able to make selections such as Hand-Off-Auto and Lead-lag; it is not possible to make these selections via the SCADA screens but set points can be adjusted.

Technical Memorandum

Santa Rosa EOP – Task 2.2 Energy Management Software Investigation

Page 3

- PLCs are programmed in ladder logic rather than via function blocks; therefore, global changes – such as revising lead-lag strategy for more than one pumping system – would require re-programming for each affected system. The hierarchy of human machine interface (HMI) objects, such as lead-lag popup screens, appears to favor a large number of customized objects rather than a smaller number of standardized plant-wide objects.
- Situational Awareness displays² in the HMI are not planned to be implemented.
- The HMI implementation follows the classical model with an overview screen (Figure 7-1) and submenu access (Figure 7-2). SCADA provisions for Reclamation and Geysers are accessible from a separate main menu accessible overview screen (Figure 7-3).
- A single programming team, led by the senior instrumentation technician, Bob Arthur, and supplemented occasionally by contractors, does all PLC and HMI programming for LTP, Reclamation, and Geysers/Station E. SCADA programming for facilities from Station E to the Geysers is by others.
- LTP SCADA has instrumentation for power monitoring of the major feeders (Figure 7-4). There are also SCADA inputs, not all of which are displayed in the HMI, for power monitoring for UV, Aeration Blowers, #3 Water Pumps, Influent Pumps, Primary Treatment, Compost, and Geysers' Pump Station. At least some adjustable frequency drives probably have power monitoring instrumentation but this capability was not confirmed.

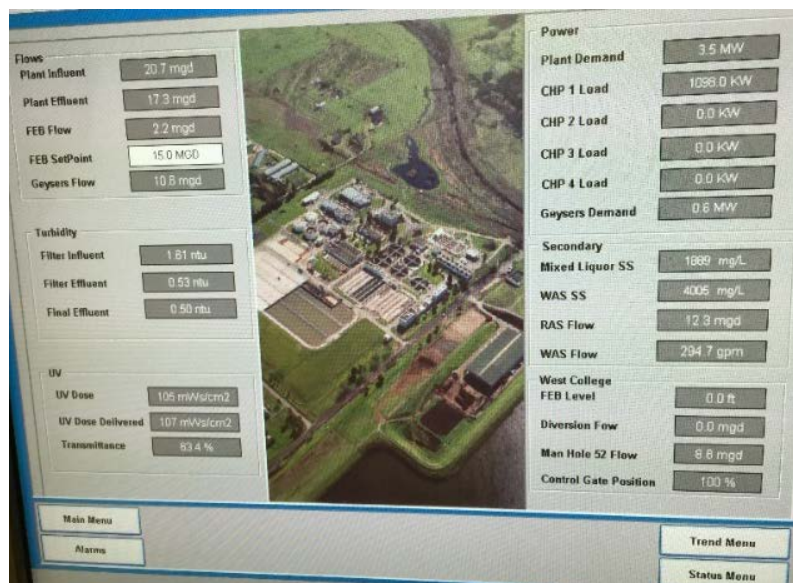

Figure 7-1: LTP Overview Screen Figure

² See http://iom.invensys.com/EN/pdfLibrary/WhitePaper_Wonderware_TheNextLeapInHMI-SituationalAwareness.pdf
TM #7

Technical Memorandum

Santa Rosa EOP – Task 2.2 Energy Management Software Investigation

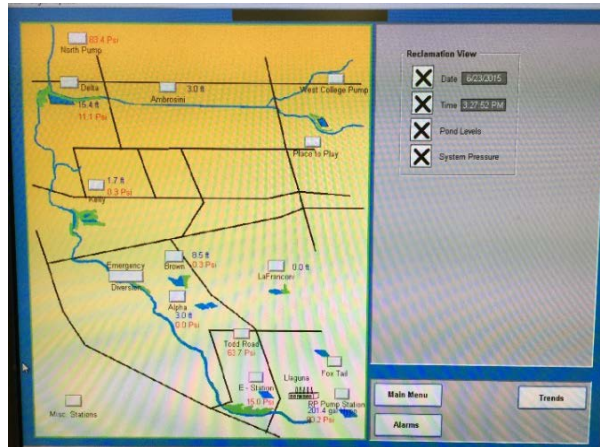

Figure 7-2: Reclamation and Geysers Overview

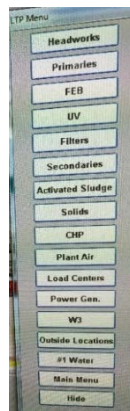

Figure 7-3: LTP Menu - Process Selection

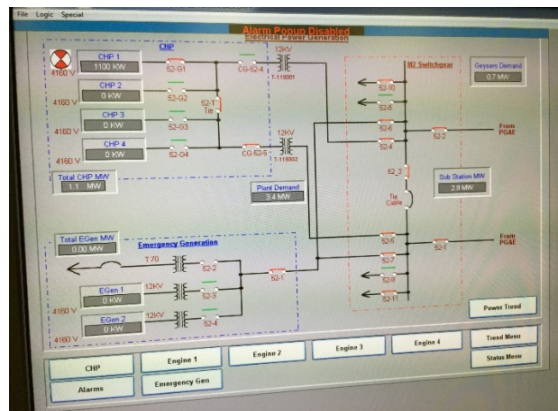

Figure 7-4: Power Monitoring for Main Feeders (kW reading in dark grey boxes)

Technical Memorandum

Santa Rosa EOP – Task 2.2 Energy Management Software Investigation

Page 5

- UV power consumption is displayed in the HMI only as a percentage (Figure 7-5) but actual wattage is historized and is available for display or via SQL if needed.
- In SCADA, some of the larger loads have current monitoring, percentage speed monitoring, or both (Figure 7-6).

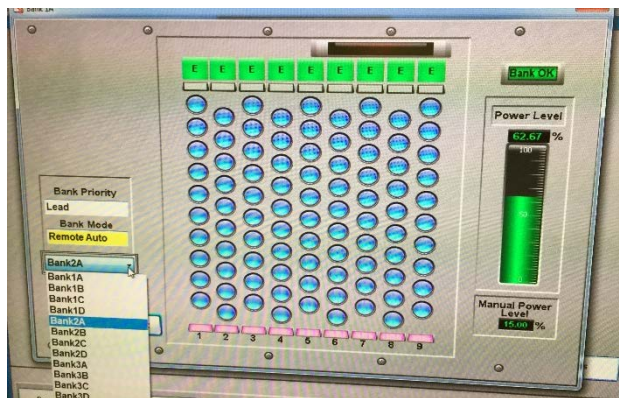

Figure 7-5: UV Power Consumption as Percentage

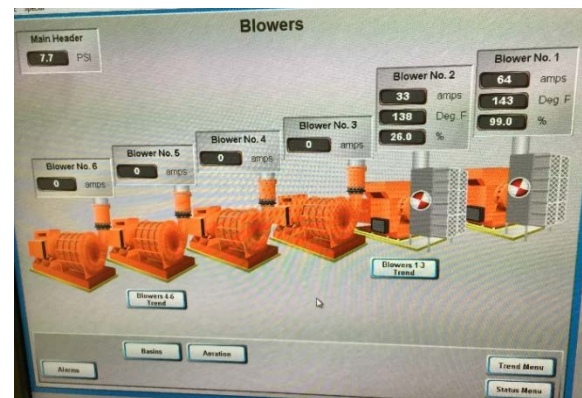

Figure 7-6: SCADA Monitoring of Motor Current and Percent Speed Monitoring

- Lead-Lag alternation control strategies aim to equalize wear and do not attempt to minimize energy consumption.
- Pump efficiency tests are done annually for some of the largest pumps, such as for Influent Pumps. While the information from these tests have reportedly been used for pump repair or replacement, it does not appear that it has been used to minimize energy consumption via operational mode selection, relay logic, PLC logic, or SCADA. Data gathered from annual tests are flows and motor currents rather than flows and power consumption.

7.3 Subregional SCADA Abilities

The Subregional SCADA system uses PLCs to implement control strategies, the latest supervisory control software from Wonderware, and local control via touchscreens. These systems are programmable and hence inherently flexible to:

- Implement control strategies to improve energy efficiency.
- Minimize energy use.
- Utilize TOU rates if so programmed.

Technical Memorandum

Santa Rosa EOP – Task 2.2 Energy Management Software Investigation

Page 6

Many existing process and SCADA control strategies already implement energy efficiency strategies by design including:

- Filter influent pump controls discharge to a common pressure header causing pumps to operate at equal outputs.
- The Combined Heat and Power (CHP) gas skid control system maximizes natural gas usage to augment digester gas, within the constraints of Santa Rosa's air permit which allows a total consumption of 10% natural gas.

In addition, standard LTP operations already take into consideration TOU rates to minimize energy use and costs by³:

- Not dewatering from the two fixed cover digesters during or just prior to peak TOU periods, avoiding digester gas system pressure drops, and keeping the CHP generation high.
- Striving to keep primary sludge pumping smooth throughout the day, to maintain digester gas production and to maintain high CHP generation.

Reviewing the SCADA screens, there does not appear to be any explicit display of electricity costs in real time using the applicable TOU rate schedules. The City does currently monitor which of its accounts are billed using TOU rates. However, as PG&E will be converting all city accounts to TOU rates in the coming years, future monitoring of rate status will become even more important. This topic is discussed in more detail in Section 7.6, Process Improvement Recommended for Further Investigation.

7.4 Recommended Energy Efficiency Measure

One strategy was identified for improving energy efficiency using SCADA.

7.4.1 EEM 7-1: Modify Pump Alternation at LTP

Present control strategies for alternating pumps at LTP seek to equalize run time. No consideration is given to relative energy efficiency of the pumping units and all the pumps for each unit process tend to wear out at about the same time. Changing the sequence of pump start/stops does not affect the unit processes but often saves energy at the expense of unequal pump run time.

Data gathered by LTP staff for the Influent Pumps earlier this year confirm that such opportunities exist, as shown in Table 7-2. The specific energy (efficiency) values indicate the

³ LTP staff recently updated the controls to allow backwashing during peak periods. This was done because the observed load reduction from the installation of a UV system may be greater than the load increase from backwash pumping. Ops suggested to maximize process efficiency they may want to do more backwashes during the peak rate period. Before making this operational change the City should investigate if the benefit from the increase in process efficiency outweighs the additional cost of shifting backwashes into the peak rate period. Until that analysis is done we cannot recommend shifting backwashes into the peak period.

Technical Memorandum

Santa Rosa EOP – Task 2.2 Energy Management Software Investigation

Page 7

amount of energy (in kWh) it takes to pump one million gallons per day (MGD). The rather large differences in efficiency indicate that energy savings are possible by preferentially using the most efficient pumps.

The efficiency values in Table 7-2, however, are an approximation because electrical data are for electrical current only and do not include adjustments based on actual voltage and actual power factor. Moreover, there is no indication of discharge pressure; therefore the amount of energy used is assumed directly proportional to the flow. However, since this data was taken for different purposes a more detailed analysis will need to be done to verify this data before implementing this EEM.

Table 7-2: Specific Energy Data for Influent Pumps (February 2015)

Pump Test Data	Specific Energy (kWh/MG) ¹
Pump #1 = 15.1 million gallons per day (MGD) and 165 Amperes (A)	196
Pump #2 = 16.7 MGD and 177 A	190
Pump #3 = 17.3 MGD and 180 A	187
Pump #4 = 18.6 MGD and 170 A	164
Pump #5 = 18.0 MGD and 160 A	160
Pump #6 = 18.3 MGD and 165 A	162

¹ Absent test data we calculated Specific Energy by assuming 480V, power factor (pf) = 0.9; $P \text{ (kW)} = I * V * pf * \sqrt{3}$; Continuous operations, $(\text{kW} * 24 \text{ hour/day}) / (\text{MGD}) = \text{kWh/MG}$.

For the Influent Pumps, two of the six operate continuously during dry weather which is most of the year. Using the existing operating protocol of equalizing run time, the average specific energy for all combinations of two pumps is 176 kWh/MG. If those two pumps were always the two most efficient pumps, i.e., pumps #5 and #6, then the average specific energy would be only 161 kWh/MG (8.9% better). If they were the two least efficient pumps (#1 & #2), the average would be 193.3 kWh/MG (9.5% worse).

Circumstances which affect this analysis change throughout the year; operators cannot just pick the two most efficient pumps and let them run all the time. Factors include:

- **Operations:** The influent pumps draw from two channels: Pumps 1-3 are in the South Channel and Pumps 4-6 are in the North. Every year each channel is out-of-service for an extended period for annual reliability maintenance, so pump selection for those periods is limited to pumps in the in-service channel.
- **Pump wear:** Pump wear is significant requiring overhaul of the wear rings every three years, so the specific energy values in Table 7-3 are probably not constant for long periods. Santa Rosa does retest the pumps annually, so continued use of the least efficient pumps can probably be minimized.

Technical Memorandum

Santa Rosa EOP – Task 2.2 Energy Management Software Investigation

Page 8

- Correction for Adjustable Speed Pumping:** Influent pumps are adjustable speed and do not operate at full speed all of the time. Pump and motor efficiencies change as speed changes. No data was made available to quantify these effects.

Regardless of circumstances, it is possible to preferentially select the most efficient pumps and avoid the least efficient. Tables, such as the following, can be used to guide operations and save energy. Using SCADA to display real-time calculations of influent pumping efficiency (see PI-1, below) can provide corrections to pumping strategy in between annual calibrations.

Table 7-3: Specific Energy Comparison of Different Pump Pairs

Pump Pairs	First Specific Energy (kWh/MG)	Second Specific Energy (kWh/MG)	Average Specific Energy (kWh/MG)	Percent Improvement Compared To Average Of All Pairs (176.5)
1,2	196.2	190.3	193.3	-9.5%
1,3	196.2	186.8	191.5	-8.5%
1,4	196.2	164.1	180.2	-2.1%
1,5	196.2	159.6	177.9	-0.8%
1,6	196.2	161.9	179.1	-1.4%
2,3	190.3	186.8	188.6	-6.8%
2,4	190.3	164.1	177.2	-0.4%
2,5	190.3	159.6	175.0	0.9%
2,6	190.3	161.9	176.1	0.2%
3,4	186.8	164.1	175.5	0.6%
3,5	186.8	159.6	173.2	1.9%
3,6	186.8	161.9	174.4	1.2%
4,5	164.1	159.6	161.9	8.3%
4,6	164.1	161.9	163.0	7.6%
5,6	159.6	161.9	160.8	8.9%

Assuming a 5% annual improvement compared to the average of all cases, the improvement for the Influent Pumps alone corresponds to an annual energy savings of about 105,100 kWh/year and first year electricity costs savings of nearly \$12,900.

Pump efficiency data for 2015 was not provided for other pumping systems at LTP, but we have found that for pumping systems at other wastewater treatment plants improvements in the range of 5% to 15%. Processes which are candidates for efficiency improvements via changes in lead-

Technical Memorandum

Santa Rosa EOP – Task 2.2 Energy Management Software Investigation

Page 9

lag sequence also include⁴ the Return Activated Sludge (RAS) and Waste Activated Sludge (WAS). Assuming a conservative 6% improvement for these two processes, the total first year savings for all three processes would be \$18,600 which would escalate with the increases in electricity rates. Table 7-4 summarizes annual energy and cost savings for all three processes.

Table 7-4: Pump Alternation Potential Annual Savings

Process	Unit Load (HP)	Unit Load (kW)	Number of Units on Continuous Load	Total Continuous Load (kW) ¹	Percent Savings (%)	Annual Energy Savings (kWh/Yr)	First Year Savings (\$/Yr)
Influent Pumping	200	120	2 of 6	240	5%	105,100	\$12,900
RAS	30	18	4 of 12	72	6%	37,800	\$4,700
WAS	25	15	1 of 2	15	6%	7,900	\$1,000
Totals						150,800	\$18,600

¹ Information about continuous loads by unit process is from the 2003 KEMA Energy Study.

Since the Influent Pumps use adjustable speed drives, actual energy savings could vary throughout the year with changes in the pump's operating point. The following graph and table show a range of potential energy savings for the influent pump at different assumed levels of savings, e.g., 5%, 10%, and 15%. The range of savings is from \$18,600 at a conservative 5% improvement in efficiency to \$44,500 at 15% improvement.

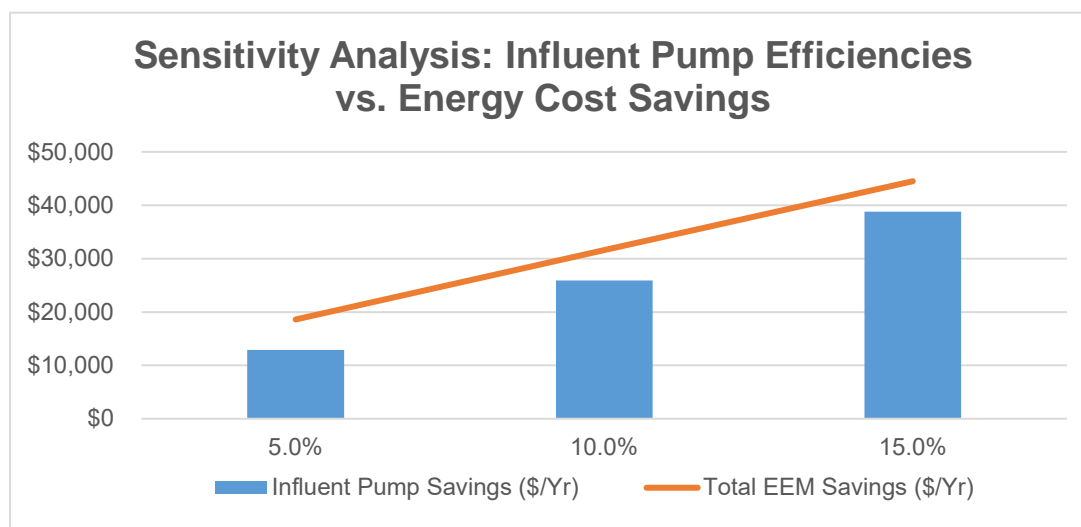

Figure 7-7: LTP Overview Screen Figure

⁴ The Filter feed pumps are **NOT** a candidate for this analysis, because changes were made to the controls in 2013 as part of the SPIG project using proprietary information.

Technical Memorandum

Santa Rosa EOP – Task 2.2 Energy Management Software Investigation

Page 10

Table 7-5: Influent Pump Savings by Percent Improvement

Influent Pump Improvement (%)	Annual Energy Savings (kWh/Yr)	Influent Pump Savings (\$/Yr)	Total EEM Savings (\$/Yr)
5.0%	105,100	\$12,900	\$18,600
10.0%	210,200	\$25,900	\$31,600
15.0%	315,400	\$38,800	\$44,500

To implement this EEM, software re-programming would be needed for the PLCs and for the operator interface. For most pumping systems at LTP, pump alternation is done in PLC logic with lead-lag options being made by either physical switches or touchscreens. Re-programming would provide a fixed and modifiable lead-lag-second lag-etc. sequence. Based on experience, it would conservatively take about two labor weeks for Santa Rosa staff to do the re-programming for the alternation scheme for each of the four processes. The annual cost of updating and testing the controls would take approximately one week of labor per year for each process. Best practices in the SCADA industry utilize either the SCADA system or local touchscreens or both to make lead-lag and other mode changes. If LTP uses either of these approaches, no hardware additions or modifications would be needed for this EEM, and therefore no capital cost is required.

A more detailed study is recommended to better define savings and costs. Elements of the study should include:

- A detailed analysis of pump efficiencies for all systems listed in Table 7-4.
- Familiarization with the controls and user interfaces for those same systems.
- Identification of implementation approach including possible installation of physical switches and instrumentation.
- An estimate of all costs for programming, installing, documenting, and testing per Santa Rosa standards.
- An estimate of the annual effort needed from LTP staff to reassess efficiencies and adjust sequences to continue to maximize energy savings.

Technical Memorandum

Santa Rosa EOP – Task 2.2 Energy Management Software Investigation

Page 11

Table 7-6: Summary of EEM 7-1 Modify Pump Alternation at LTP

Electricity Savings (kWh/Yr)	Electricity Savings (\$/1 st Yr)	GHG Emission Reduction (MT/Yr)	Capital Cost (\$)	Incentive Amount (\$)	Avg. Annual Net Savings (\$/Yr)	Cumulative Net Savings (\$)	NPV of Cumulative Net Savings (\$)	ROR (%)	Cumulative GHG Reductions (MT)
150,800	\$18,600	15	\$29,800	\$12,000	\$16,700	\$335,700	\$235,000	67%	960

7.5 Recommended Process Improvement (PI)

Process Improvements (PIs) differ from the Energy Efficiency Measures (EEMs) in that PIs do not necessarily result in electrical savings but provide information that could result in improved process efficiency.

7.5.1 PI 7-1: SCADA Screens and Instruments to Facilitate Energy Management

To optimize energy savings and know how systems are performing between annual tests, some means of monitoring performance in real time is needed. Technical Memorandum #1 – LTP Process Energy Audit (PI 1-2: Enhance SCADA Screens), recommends adding a SCADA energy screen to make energy consumption observable and manageable in real time. While it is not necessary to add instrumentation to reap some of the benefits estimated in EEM 7-1, it is recommended that PI 1-2 be expanded to include:

- Adding energy instrumentation tied to SCADA for the largest individual loads including Influent Pumps, Secondary Aeration Blowers, and Filter Feed Pumps.
- Adding specific energy displays and trends for Influent Pumps, Secondary Aeration Blowers, and Filter Feed Pumps.
- Adding to the existing energy instrumentation tied to SCADA to include all large feeders.
- Adding real time energy monitoring displays to SCADA where instrumentation already exists, e.g., certain adjustable speed drives and the UV units.
- Adding the explicit display of electricity costs in real time using the applicable TOU rate schedules, so operators can see actual costs of energy.
- SCADA display of current monthly Peak Demand.

Typical equipment needed for each circuit would be an energy monitor such as Schneider's Ethernet-connected METSEPM5340 (\$1,000 list price) and three current transformers (about \$300 total). Assuming labor and installation costs are approximately equal, the cost would be about \$3,000 per meter. This recommended new instrumentation would be on the 480 Volt distribution system only. The quantities of needed meters are shown in Table 7-7.

Technical Memorandum

Santa Rosa EOP – Task 2.2 Energy Management Software Investigation

Page 12

Table 7-7: Proposed Additional Meters for SCADA

Load Name	# of Meters	Comment & Location
Individual Process Loads		
Influent Pumps	6	MCC-2A & MCC-2F
Filter Feed Pumps	4	MCC-51S (Figure 7)
RAS & WAS MCC	14	MCC-6Q, MCC 3H
Blowers (Turblex)	2	LC-80 (Figure 8)
Total	26	
Distribution System		
LC-10	2	
LC-20	2	
LC-30	0	existing
LC-50	0	existing
Total	4	

Capital cost for instrumenting the 26 listed individual process loads would be about \$78,000 and an additional \$12,000 would be needed for apparent 4 power metering omissions for the feeders for LC-10 and LC-20.

This PI would provide operators a more complete picture of real time and historical energy usage at LTP, and information will help identify additional opportunities for process improvement, increased energy savings, and alert operators to possible adverse trends. While there may be economic benefit of this process improvement we did not calculate one for this analysis.

Technical Memorandum

Santa Rosa EOP – Task 2.2 Energy Management Software Investigation

Page 13

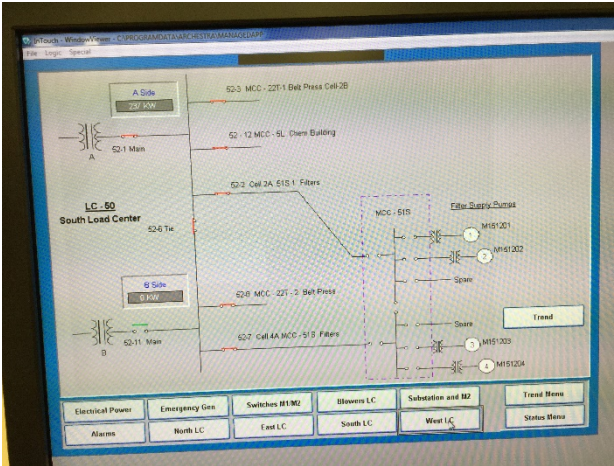

Figure 7-8: Energy Monitoring at South Load Center

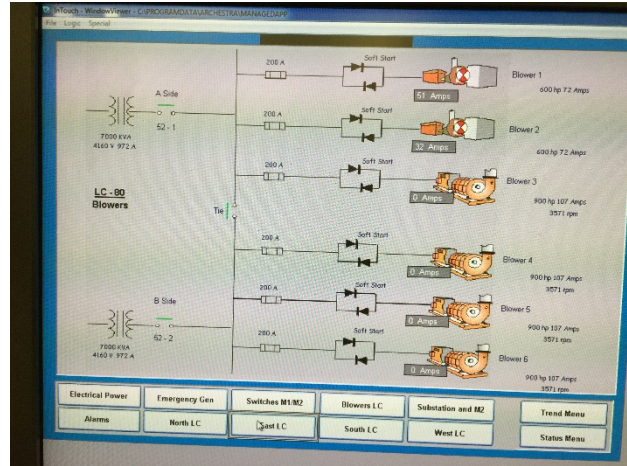

Figure 7-9: Energy Monitoring at Blower Load Center

7.6 Process Improvements Recommended for Further Investigation

7.6.1 PI 7-2: Monitor TOU Rate Changes

Some of the City's energy accounts are currently on TOU rates, and the remainder will be converted at a future date. This is a requirement of the California Public Utilities Commission.

For accounts that are on TOU rates, instead of a single flat rate (\$/kWh) for energy use, TOU rates are higher when electric demand is higher. As such, *when* the City uses energy is just as important as *how much* it uses. Under TOU rates, winter has two rate periods: off-peak and partial-peak. Summer has three: off-peak, partial-peak and peak. During peak periods, electric rates are higher. In return, all other times are lower than the peak rate.⁵ The following graphic shows the hours for on-peak, partial-peak, and off-peak rates for summer and winter.⁶

⁵ PG&E, 2016. Time-Varying Pricing website. Available at: http://www.pge.com/en/mybusiness/rates/tpv/toupricing.page?WT.mc_id=Vanity_TOU. Accessed May 11, 2016.

⁶ PG&E, 2016. Time-Varying Pricing Guide. Provided by John Suazo, J.D., Senior Customer Relationship Manager, PG&E, May 11, 2016.

Technical Memorandum

Santa Rosa EOP – Task 2.2 Energy Management Software Investigation

Page 14

SUMMER

May 1 through October 31

WINTER

November 1 through April 30

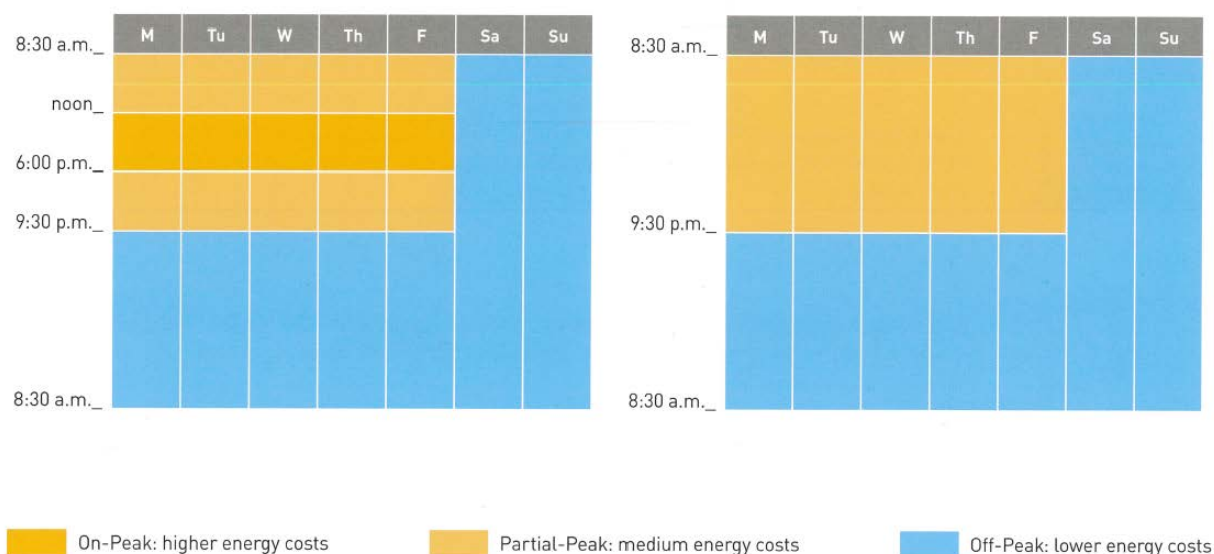

Figure 7-10: PG&E Time-of-Use Guidelines.

All business customers will transition to TOU rate plans over the next several years, as required by the California Public Utilities Commission. The date of conversion for the remainder of the City’s accounts is still being determined, and is based on the timing of conversion of the City’s meters to smart meters. The City will continue to closely communicate with its energy suppliers (Pacific Gas and Electric and Sonoma Clean Power) to receive ample advance notice of when accounts will be converted, to best plan for potential changes to the timing of water systems operations.

7.6.2 PI 7-3: Use the Flow Equalization Basin for Peak Shaving

The Flow Equalization Basin (FEB) is presently available for peak shaving during on-peak periods but is not being used for this purpose because of the adverse impacts on LTP operations. Once those operational issues have been addressed, and a new UV disinfection system is in place we recommend revisiting this process improvement. Joe Schwall, Treatment Superintendent, summarized this situation as follows:

Technical Memorandum

Santa Rosa EOP – Task 2.2 Energy Management Software Investigation

Page 15

“Until relatively recently, we used to use the FEB to store a large proportion of primary effluent during peak summertime demand times, minimizing aeration, RAS pumping, filter pumping, and UV disinfection costs. More recently, our disinfection system was de-rated, so the high off-peak flows became problematic and the practice was discontinued until we build a new disinfection system (four years out). We participate in a load shedding program through our utility and divert to the FEB occasionally when a load shedding event is called.”

7.6.3 PI 7-4: Optimization of the Turblex Blowers

While on-site, we observed that the two fixed-speed Turblex blowers run at quite different loads (see Figure 7-8). We contacted Curtis Rodgers of Turblex (phone: 800-299-1035) to see if this was the most energy-efficient mode of operation or if some control system change could increase efficiency.

Mr. Rodgers stated the following:

- Santa Rosa’s blowers are operating in “cascade mode” in which one unit takes the “base load” and the other provides changes in air flow as needed.
- Cascade mode is the most energy efficient way to run the two units as presently configured.
- Switching from fixed speed to variable speed drives can improve energy efficiency by 2% to 3%, but this apparently is not a cost-effective change.
- Switching to higher efficiency fixed speed motors is typically cost-effective.

Based on this information, we recommend:

- Investigating if switching to higher efficiency fix speed motors is cost-effective.
- Confirming that the more energy efficient of the two Turblex blowers is carrying the base load.
- Confirming, based on input from Mr. Rodgers, that the set point and process variable are the same on the Turblex Master Control Panel.

7.6.4 PI 7-5: Energy Management System for the Recycled Water System

There are commercially available energy management systems (EMS) which have been shown to reduce energy costs associated with the pumping and distribution of water. Derceto, Innovyze, and others provide EMS packages. Santa Rosa’s Recycled Water System would appear to be a candidate for EMS, perhaps in conjunction with present investigations for Local Ops.

EMS products typically have the following operational characteristics:

- Obtain operating data from SCADA.

Technical Memorandum

Santa Rosa EOP – Task 2.2 Energy Management Software Investigation

Page 16

- Feed it into a hydraulic model⁷ of the water distribution system.
- Apply water system operational constraints.
- Apply utility rates for electricity and/or gas including TOU and Real Time rate structures.
- Input individual pump efficiency ratings, and implement a first-on-first-off protocol based on individual pump efficiencies.
- Update a system-wide two-day pumping schedule every 30 minutes.
- Send the updated pumping schedule to the SCADA system automatically for implementation.

Expanding on the scheduling strategy described in Technical Memorandum #3: EEM 6 - Optimize Operations for TOU Rates, EMS also take into consideration the minimization of friction losses in the distribution system.

There are important issues to understand when considering an EMS:

- The first is the high capital cost that is often over \$1,000,000 for complex water distribution systems.
- Second, extraordinary operational discipline and teamwork are required to optimize EMS. For example, if an operator manually overrides automatic control in the SCADA system and inadvertently fails to change settings in the EMS appropriately, it will likely prevent updates in EMS pumping schedule until the settings problem is discovered and corrected. EMS are highly sensitive to settings being incorrect; even a single incorrect pump setting can prevent updates in the pumping schedules for a large portion of the distribution system. The lack of updates in the pumping schedules can lead to less than optimum energy management and less than anticipated savings.
- Finally, EMS reportedly works best at reducing energy costs when the entire distribution system is left in “auto”. Those utilities whose operators prefer to make frequent manual corrections may face subpar performance and lower savings.

Our experience with Eastern Municipal Water District, who installed the Derceto Aquadapt EMS in 2006, is that EMS installations can provide significant energy savings in the range of 6%-11% per year.

While a detailed study is needed to estimate how an EMS might perform for Santa Rosa we modelled an EMS with a \$1 million installation cost that saves 9% of electric purchases per year in the Recycled Water System. As shown in Table 7-8 the high capital cost overwhelms the modest energy savings making this option not cost-effective and therefore not recommended.

⁷ Some products use a full hydraulic model while others use a skeletal hydraulic model; i.e., a simplified model to speed processing time.

Technical Memorandum

Santa Rosa EOP – Task 2.2 Energy Management Software Investigation

Page 17

Whether this improvement would be cost effective when combined with similar upgrades for Local Ops is a matter for future study.

Table 7-8: PI 7-4 Energy Management System for Recycled Water System

Electricity Savings (kWh/Yr)	Electricity Savings (\$/1 st Yr)	GHG Emission Reduction (MT/Yr)	Capital Cost (\$)	Incentive Amount (\$)	Avg Annual Net Savings (\$/Yr)	Cumulative Net Savings (\$)	NPV of Cumulative Net Savings (\$)	ROR (\$)	Cumulative GHG Reductions (MT)
183,900	\$22,600	19	\$985,000	\$14,700	(\$39,500)	(\$789,900)	(\$601,500)	-3.0%	374

June 1, 2017

Final Technical Memorandum # 8

To: Mike Prinz, Mike Sherman, Rip Forrey, Tasha Wright, and Claire Myers, City of Santa Rosa

From: Rod Houser – Irrigation System Optimization Investigation Lead
Melanie Tan – Project Analyst
Alan Zelenka – Kennedy/Jenks Project Manager

Subject: Task 2.3 – Irrigation System Optimization Investigation

8.1 Goal of this Irrigation System Optimization Investigation

The primary purpose of this technical memorandum is to determine if recycled water pump replacement is a cost-effective energy-efficiency measure (EEM). To accomplish this, the specific energy (kWh/Mgal) and overall efficiency for ten City-owned pumps was measured. In addition we computed the energy savings and calculated the net cost or benefit.

The following ten pumps were chosen for this analysis based on their high energy use, high volume of water pumped, and because the City had test results for their overall pumping efficiency (OPE):

1. Dotti Pump
2. Aggio and Gleason Pump
3. Carinalli 1 Pump
4. LaFranconi Pond Pump
5. Dei South Pump
6. Beretta South
7. Hansen East Pump
8. Mello East Pump
9. Matos Cheese Factory Pump
10. La Franconi Pipeline Pump

8.2 Recommendation Summary

Of the ten pumps analyzed, three were cost-effective to replace with high efficiency pumps. Those three replacement pumps will save approximately 38,000 kWh per year and create an

Memorandum

Santa Rosa EOP – Task 2.3 Irrigation System Optimization Investigation

Page 2

annual average net savings of approximately \$2,800. This would result in a cumulative net savings of over \$37,000 (net present value [NPV]) over the life of the pumps.

Table 8-1: Summary of Recommended Energy Efficiency Measures (Replacement Pumps)

EEM #	Pump	Electricity Savings (kWh/Yr)	Capital Cost (\$)	Incentive Amount (\$)	Avg Annual Net Savings (\$/Yr)	NPV of Cumulative Net Savings (\$)
8-2A	Aggio Pump	20,300	\$30,000	\$3,100	\$1,600	\$21,200
8-7	Hansen East Pump	10,700	\$15,000	\$1,300	\$900	\$11,700
8-10	La Franconi Pipeline Pump	6,600	\$12,500	\$1,500	\$300	\$4,300
TOTAL		37,600	\$57,500	\$5,900	\$2,800	\$37,200

Table 8-2: Energy Efficiency Measures Recommended for Further Investigation

EEM #	Title
8-11	Continue Pump Testing Program
8-12	Upgrade Delta Pump #2
8-13	Transfer Ownership of Vineyard Pumps

8.3 Background and Methodology

Starting in 2008 the City has been performing performance tests at its recycled-water pump stations. OPE (%) and specific energy (kWh/Mgal) are measured during each test. If the measured OPE is less than 74%, a savings and cost analysis is performed to determine if replacing the pump is cost-effective.

OPE, also known as wire-to-water efficiency, is defined as the combined efficiency of the pump-and-motor system. It is measured by dividing the hydraulic power that the pump produces by the electricity that the motor requires. In an optimal case, motor efficiency should be above 92% and the pump efficiency should be above 75%. Such a condition results in an OPE of 69% for the optimal pump. A lower OPE indicates a potential to reduce energy costs by replacing the pump with a more-efficient unit.

The City has used information taken from these tests to optimize the energy performance of its pumps and pumping systems. Some examples of recent energy optimization projects include:

Memorandum

Santa Rosa EOP – Task 2.3 Irrigation System Optimization Investigation

Page 3

1. The motor at Stone farm was downsized from 100 to 60 HP during the 2015 irrigation season. A pre-test was performed in 2015 with the 100 HP motor. The City will perform a post test in 2016 on the 60 HP motor to receive a PG&E rebate.
2. In 2015 the City installed a valve and main line extension on LaFranconi Pond pump station. This allowed the City to eliminate the LaFranconi East pump station.
3. In 2016, the City will install a main line from Dei south to Dei north pump station. The Dei south station will operate the entire farm, eliminating the Dei North (home) pump station from the system.

For this analysis, baseline energy consumption for a given pump was estimated by multiplying the measured specific energy (kWh/Mgal) by the annual volume of water pumped (Mgal). The potential cost savings from pump replacement is estimated by calculating the electricity that would be consumed if the OPE was increased to 69% (the optimal case). Information from the “PETS Pump Test 2015 City SR Rec Prog Rip” spreadsheet and 2016 flow data, provided by the City, was used for these calculations.

The analysis evaluated the benefit of selecting a new pump that operates at the same duty conditions (i.e., flow and pressure), but with higher efficiency. New pumps were considered such that hydraulic conditions of operation would coincide with the pump’s best efficiency point (BEP). Duty conditions for the pump were specified to provide an average efficiency of at least 75% for the pump and 92% for the motor. None of the replacement pump projects should impact the end user, because the new pump is specified to provide the same flow and pressure.

Also, all the new pumps in this analysis should remain serviceable for approximately 20 years or more. The cost associated with periodic end-of-life replacements was deemed to be equivalent to the existing pump because it would also require end-of-life replacements at similar intervals. Cost savings from O&M for all pump replacements in this analysis were assumed to be zero because the new pump would not require any additional work to maintain, compared to the existing unit.

8.4 Recommended Energy Efficiency Measures

This analysis evaluated the potential replacement of ten pumps, and found that three are recommended for replacement at this time based on performance and savings. While the City has been performing in-house pump station upgrades based on efficiency reports and current needs of its system for many years, and is up-to-date with replacing most outdated systems, the City may want to consider replacing the three pumps describes in this section.

8.4.1 EEM 8-2A: Replace Aggio Pump

The 60 HP Aggio centrifugal pump was identified as inefficient due to the low (44%) OPE. This EEM would replace the pump with an optimized unit of the same size that could provide an OPE of at least 69%.

The pump conveyed approximately 48.5 million gallons of water during the 2016 pumping season (May through October). Capital cost for a new Aggio replacement pump would be approximately \$24,000 which is based on a cost of \$400/HP. Engineering costs would be an

Memorandum

Santa Rosa EOP – Task 2.3 Irrigation System Optimization Investigation

Page 4

additional approximately \$6,000 based on 25% of capital costs, for a total project cost of \$30,000.

Energy savings from this EEM are estimated at over 20,000 kWh/year. In addition, there will be an incentive through the PG&E Customized Incentive Program. The amount of the rebate comprises two parts and is calculated by (i) multiplying the annual energy savings by \$0.08/kWh (e.g. 20,300 kWh x \$0.08/kWh = \$1,600) and adding (ii) the estimated kW saved per year multiplied by the \$150 /kW saved (9.8 kW/year x \$150/kW = \$1,500). The average annual net savings would be about \$1,600. The NPV of cumulative annual net savings would be \$21,200, and the rate of return (ROR) would be about 10%. The table below shows that installing EEM 8-2A would be cost-effective. However, the City has noted that the Pumping Efficiency Testing Services (PETS) results may be inaccurate because the Aggio pump shares an electrical meter with the other pump onsite, the Gleason/Nahmens pump (evaluated in Section 8.6.2). As such, the data should be verified prior to making any definitive decisions regarding an upgrade.

Table 8-3: Summary of EEM 8-2A Replace Aggio Pump

Electricity Savings (kWh/Yr)	Electricity Savings (\$/1 st Yr)	GHG Emission Reduction (MT/Yr)	Capital Cost (\$)	Incentive Amount (\$)	Avg Annual Net Savings (\$/Yr)	Cumulative Net Savings (\$)	NPV of Cumulative Net Savings (\$)	ROR (%)
20,300	\$2,400	2	\$30,000	\$3,100	\$1,600	\$31,600	\$21,200	10.0%

8.4.2 EEM 8-7: Replace Hansen East Pump

The 30 HP centrifugal pump was identified as inefficient due to the low (52%) OPE. This EEM would replace the pump with an optimized unit of the same size that could provide an OPE of at least 69%. The Hansen East property conveyed approximately 44.7 million gallons in the 2016 pumping season. Capital cost for the new pump would be approximately \$12,000, which is based on a cost of \$400/HP. Engineering costs were estimated to be \$3,000 based on 25% of capital costs.

Energy savings from this EEM are about 10,700 kWh/year. The incentive would be approximately \$1,300. The average annual net savings would be about \$900. The NPV of cumulative annual net savings would be \$11,700, and the ROR would be about 10.5%. The table below shows that installing EEM 8-7 would be cost-effective.

However, the City has noted that the PETS results may be inaccurate because flow from manure injection is not calculated and included, and there are motor and flow meter issues. In addition, City staff are not certain that more load can be added to the existing PG&E feed. Consequently, all data should be verified prior to making any definitive decisions regarding an upgrade.

Memorandum

Santa Rosa EOP – Task 2.3 Irrigation System Optimization Investigation

Page 5

Table 8-4: Summary of EEM 8-7 Hansen East Pump

Electricity Savings (kWh/Yr)	Electricity Savings (\$/1 st Yr)	GHG Emission Reduction (MT/Yr)	Capital Cost (\$)	Incentive Amount (\$)	Avg Annual Net Savings (\$/Yr)	Cumulative Net Savings (\$)	NPV of Cumulative Net Savings (\$)	ROR (%)
10,700	\$1,300	1	\$15,000	\$1,300	\$900	\$17,300	\$11,700	10.5%

8.4.3 EEM 8-10: Replace La Franconi Pipeline Pump

The 25 HP centrifugal pump was identified as inefficient due to the low (45%) OPE. This EEM would replace the pump with an optimized unit of the same size that could provide an OPE of at least 69%. The La Franconi Pipeline Pump conveyed an annual total of 19.2 million gallons in 2016. Capital cost for the new pump would be approximately \$10,000, which is based on a cost of \$400/HP. Engineering costs were estimated to be \$2,500 based on 25% of capital costs.

Energy savings from this EEM are about 7,100 kWh/year. The incentive would be approximately \$1,600. The average annual net savings would be about \$450. The NPV of cumulative annual net savings would be \$5,800, and the ROR would be about 8.3%. The table below shows that installing EEM 8-10 would be cost-effective.

However, the City has noted that the PETS may be inaccurate because there are flow meter issues. In addition, City staff are not certain that more load can be added to the existing PG&E feed. Consequently, all data should be verified prior to making any definitive decisions regarding an upgrade.

Table 8-5: Summary of EEM 8-10 Replace La Franconi Pipeline Pump

Electricity Savings (kWh/Yr)	Electricity Savings (\$/1 st Yr)	GHG Emission Reduction (MT/Yr)	Capital Cost (\$)	Incentive Amount (\$)	Avg Annual Net Savings (\$/Yr)	Cumulative Net Savings (\$)	NPV of Cumulative Net Savings (\$)	ROR (%)
6,600	\$800	1	\$12,500	\$1,500	\$300	\$6,800	\$4,300	7.2%

8.5 Energy Efficiency Measures Recommended for Further Investigation

8.5.1 EEM 8-11: Continue Pump Testing Program

The City performs on-site tests of its pump stations every 4 to 5 years. The City will continue to implement its aggressive testing and monitoring program to routinely measure and document pump performance at every City-owned irrigation pump. It will consider prioritizing testing at

Memorandum

Santa Rosa EOP – Task 2.3 Irrigation System Optimization Investigation

Page 6

pumps that move a high volume of water and/or use a large amount of energy but have not been tested to date, such as Delta, Peters/McClelland, Poncia/Terri-Linda pumps, or testing all pumps in 2017 to establish baseline data for all systems at one time.

At a minimum, the City will continue to measure and monitor the following parameters:

- Flow in gallons per minute (gpm).
- Suction and discharge pressures.
- Runtime since last performance measurements (hours).
- Motor current, voltage and power factor.
- Nameplate data.
- PG&E meter number(s) that serve the pumps.

Permanently installed instrumentation for these parameters will continue to be considered any time a new pump station is constructed, or an upgrade existing facility is planned. This will allow the parameters to be measured and trended using the City's SCADA system. The real-time data will also allow operations staff to detect and correct equipment problems before they become a bigger issue. Portable instruments can also be used wherever permanent instrumentation is impractical.

All of this data will continue to be routinely added to the City's asset management database to allow for performance benchmarking and continuous energy optimization. As of early 2017, City had 31 stations on the City SCADA system. The City will continue to add a few new stations to the SCADA system every year with in-house staff, first moving the larger users and then adding the smaller users. The benefit to the City is irrigation taking place in off-peak times. The benefit to the City's customers is increased irrigation distribution uniformity.

8.5.2 EEM 8-12: Upgrade Delta Pump #2

Delta Pump Station consists of two 350 HP pumps at 8,000 gpm at 100 feet Total Dynamic Head (TDH) variable speed vertical turbine pumps, and one 75 HP pumps at 7,000 gpm at 30 feet TDH constant speed vertical turbine pump. All pumps are manually activated, and due to PG&E power constraints may only be run individually. The two variable speed pumps modulate to maintain a system pressure setpoint, and both have a minimum run speed of 20 percent motor output. The station Programmable Logic Controller (PLC) continuously monitors pump status, wet well level, and system pressure. Station operation currently consists of a single variable speed pump running continuously, ramping up in speed to supply mainline flow during periods of irrigation usage, or running in an "idle mode" and not moving any water when system usage is low. The smaller constant speed pump is used sparingly, as it lacks the capacity to supply adequate flow for irrigation usage and requires constant monitoring by operators.

The City should consider replacing (retrofitting) the smaller constant speed motor with a third variable speed drive, and reprogramming the station PLC to have the ability to automatically alternate online pumps, using the smaller pump for low or no demand periods (similar to

Memorandum

Santa Rosa EOP – Task 2.3 Irrigation System Optimization Investigation

Page 7

Rohnert Park Pump Station). This upgrade should be further investigated to determine if it would better meet the needs of the system while also saving energy.

Memorandum

Santa Rosa EOP – Task 2.3 Irrigation System Optimization Investigation

Page 8

8.5.3 EEM 8-13: Transfer Ownership of Vineyard Pumps

The City owns and operates three pump stations that serve vineyards: Vanazza, JWW, and Hansel. These stations are conversions from pasture/hay operations to vineyard use only. Typically for vineyards, the City provides water to vineyards but it is the vineyard operators' responsibility to install, operate, maintain, and pay electricity costs necessary for pumping operations. For these pump stations, however, the City maintains the facilities and pays for the electricity they require.

The City should consider transferring responsibilities and ownership of the existing facilities to these vineyard owners, in keeping with how it manages similar facilities. The City should do a cost-benefit analysis that considers the current value of the infrastructure considering depreciation, the energy and (potential) cost savings the City would achieve from transferring ownership, and various options for transfer including gifting the infrastructure or having property owners purchase the facilities at salvage value. The analysis should provide enough information for the City to determine if transferring the facilities makes sense for energy and cost reasons.

8.5.4 Summary of All Recommended Energy Efficiency Measures

Capital cost for the new recommended three pump replacements would be approximately \$58,000. Annual energy savings from these EEMs would be about 37,600 kWh. The incentive would be approximately \$5,900. The average annual net savings would be about \$2,800. The NPV of cumulative annual net savings would be about \$37,200.

Table 8-6: Summary of All Recommended Energy Efficiency Measures

EEM #	Pump	Electricity Savings (kWh/Yr)	Electricity Savings (\$/1 st Yr)	GHG Emission Reduction (MT/Yr)	Capital Cost (\$)	Incentive Amount (\$)	Avg Annual Net Savings (\$/Yr)	Cumulative Net Savings (\$)	NPV of Cumulative Net Savings (\$)	ROR (%)
EEM-8-2A	Aggio	20,300	\$2,400	2	\$30,000	\$3,100	\$1,600	\$31,500	\$21,200	10.0%
EEM-8-7	Hansen East	10,700	\$1,300	1	\$15,000	\$1,300	\$900	\$17,300	\$11,700	10.5%
EEM-8-10	La Franconi Pipeline	6,600	\$800	1	\$12,500	\$1,500	\$300	\$6,800	\$4,300	7.2%
	TOTAL	37,600	\$4,500	4	\$57,500	\$5,900	\$2,800	\$55,600	\$37,200	

Memorandum

Santa Rosa EOP – Task 2.3 Irrigation System Optimization Investigation

Page 9

8.6 Not Recommended Energy Efficiency Measures

8.6.1 EEM 8-1: Replace Dotti Pump

The 75 HP Dotti pump was identified as inefficient due to the low (56%) OPE. This EEM would replace Dotti pump with an optimized unit of the same size that could provide an OPE of at least 69%.

The Dotti Pump conveyed an annual total of 65.7 million gallons in the 2016 pumping season. Capital cost for the new pump would be approximately \$45,000, which is based on a cost of \$600/HP. Engineering costs were estimated to be \$11,300 based on 25% of capital costs. Energy savings from this EEM are about 11,500 kWh. The incentive would be approximately \$2,900. This EEM would result in an average annual net COST to Santa Rosa of about \$1,900. The NPV of cumulative annual net cost would be almost \$30,000. The table below shows that installing EEM 8-1 would NOT be cost-effective.

Table 8-7: Summary of EEM 8-1 Replace Dotti Pump

Electricity Savings (kWh/Yr)	Electricity Savings (\$/1 st Yr)	GHG Emission Reduction (MT/Yr)	Capital Cost (\$)	Incentive Amount (\$)	Avg Annual Net Savings (\$/Yr)	Cumulative Net Savings (\$)	NPV of Cumulative Net Savings (\$)	ROR (%)
11,500	1,400	1	\$56,300	\$2,900	(\$1,900)	(\$38,700)	(\$29,700)	-2.2%

8.6.2 EEM 8-2B Replace Gleason/Nahmen Pump

There are two pump stations at this location: The Aggio Pump and the Gleason/Nahmens pump. The 60 HP Gleason/Nahmens pump was identified as inefficient due to the low (56%) OPE. This EEM would replace the Gleason/Nahmens pump with an optimized unit of the same size that could provide an OPE of at least 69%.

The Gleason/Nahmen Pump conveyed approximately 42 million gallons in the 2016 pumping season. Capital cost for the new pump would be approximately \$24,000, which is based on a cost of \$400/HP. Engineering costs were estimated to be \$6,000 based on 25% of capital costs. Energy savings from this EEM are about 7,000 kWh. The incentive would be approximately \$1,900. This EEM would result in an average annual net COST to Santa Rosa of about \$900. The NPV of cumulative annual net cost would be \$13,400. The table below shows that installing EEM 8-2B would NOT be cost-effective.

Table 8-8: Summary of EEM 8-2B Replace Gleason/Nahmen Pump

Memorandum

Santa Rosa EOP – Task 2.3 Irrigation System Optimization Investigation

Page 10

Electricity Savings (kWh/Yr)	Electricity Savings (\$/1 st Yr)	GHG Emission Reduction (MT/Yr)	Capital Cost (\$)	Incentive Amount (\$)	Avg Annual Net Savings (\$/Yr)	Cumulative Net Savings (\$)	NPV of Cumulative Net Savings (\$)	ROR (%)
7,000	\$800	1	\$30,000	\$1,900	(\$900)	(\$17,200)	(\$13,400)	-1.1%

8.6.3 EEM 8-3: Replace Carinalli 1 Pump

The 60 HP centrifugal pump was identified as inefficient due to the low (56%) OPE. This EEM would replace the pump with an optimized unit of the same size that could provide an OPE of at least 69%. The existing pump conveyed approximately 37.8 million gallons in the 2016 pumping season.

Capital cost for the new pump would be approximately \$24,000, which is based on a cost of \$400/HP. Engineering costs were estimated to be \$6,000 based on 25% of capital costs. Energy savings from this EEM are about 5,300 kWh. The incentive would be approximately \$1,500. This EEM would result in an average annual net COST to Santa Rosa of about \$1,200. The NPV of cumulative annual cost would be \$18,000. The table below shows that installing EEM 8-3 would NOT be cost-effective.

Table 8-9: Summary of EEM 8-3 Replace Carinalli 1 Pump

Electricity Savings (kWh/Yr)	Electricity Savings (\$/1 st Yr)	GHG Emission Reduction (MT/Yr)	Capital Cost (\$)	Incentive Amount (\$)	Avg Annual Net Savings (\$/Yr)	Cumulative Net Savings (\$)	NPV of Cumulative Net Savings (\$)	ROR (%)
5,300	\$600	1	\$30,000	\$1,500	(\$1,200)	(\$23,700)	(\$18,000)	-3.4%

8.6.4 EEM 8-4: Replace La Franconi Pond Pump

The 50 HP centrifugal pump was identified as inefficient due to the low (55%) OPE. This EEM would replace the pump with an optimized unit of the same size that could provide an OPE of at least 69%. The existing pump conveyed approximately 63 million gallons in the 2016 pumping season.

Capital cost for the new pump would be approximately \$20,000, which is based on a cost of \$400/HP. Engineering costs were estimated to be \$5,000 based on 25% of capital costs. Energy savings from this EEM are about 10,100 kWh. The incentive would be approximately \$1,900. This EEM would result in an average annual net saving to Santa Rosa of about \$60. However, the NPV of cumulative annual COST would be about \$90. The table below shows that installing EEM 8-4 would NOT be cost-effective.

Table 8-10: Summary of EEM 8-4: Replace La Franconi Pond Pump

Memorandum

Santa Rosa EOP – Task 2.3 Irrigation System Optimization Investigation

Page 11

Electricity Savings (kWh/Yr)	Electricity Savings (\$/1 st Yr)	GHG Emission Reduction (MT/Yr)	Capital Cost (\$)	Incentive Amount (\$)	Avg Annual Net Savings (\$/Yr)	Cumulative Net Savings (\$)	NPV of Cumulative Net Savings (\$)	ROR (%)
10,100	\$1,200	1	\$25,000	\$1,900	\$60	\$1,300	(\$90)	4.0%

8.6.5 EEM 8-5: Replace Dei South Pump

The 60 HP centrifugal pump was identified as inefficient due to the low (53%) OPE. This EEM would replace the pump with an optimized unit of the same size that could provide an OPE of at least 69%. The existing pump conveyed approximately 37 million gallons in the 2016 pumping season.

Capital cost for the new pump would be approximately \$24,000, which is based on a cost of \$400/HP. Engineering costs were estimated to be \$6,000 based on 25% of capital costs. Energy savings from this EEM are about 10,000 kWh. The incentive would be approximately \$2,500. This EEM would result in an average annual net COST to Santa Rosa of about \$300. The NPV of cumulative annual cost would be about \$5,200. The table below shows that installing EEM 8-5 would NOT be cost-effective.

It should be noted that the City has also commented that this pump was oversized for the application when the pumps tests were being carried out. This was intentionally done as the City was planning to phase out pumping at Dei North (implemented in the summer of 2016). It is recommended that pump tests be carried out after the transition to assess the pump's current energy efficiency.

Table 8-11: Summary of EEM 8-5: Replace Dei South Pump

Electricity Savings (kWh/Yr)	Electricity Savings (\$/1 st Yr)	GHG Emission Reduction (MT/Yr)	Capital Cost (\$)	Incentive Amount (\$)	Avg Annual Net Savings (\$/Yr)	Cumulative Net Savings (\$)	NPV of Cumulative Net Savings (\$)	ROR (%)
10,000	\$1,200	1	\$30,000	\$2,500	(\$300)	(\$5,6700)	(\$5,200)	2.2%

8.6.6 EEM 8-6: Replace Beretta South Pump

The 60 HP centrifugal pump was identified as inefficient due to the low (53%) OPE. This EEM would replace the pump with an optimized unit of the same size that could provide an OPE of at least 69%. The existing pump conveyed approximately 50 million gallons in the 2016 pumping season.

Memorandum

Santa Rosa EOP – Task 2.3 Irrigation System Optimization Investigation

Page 12

Capital cost for the new pump would be approximately \$24,000, which is based on a cost of \$400/HP. Engineering costs were estimated to be \$6,000 based on 25% of capital costs. Energy savings from this EEM are about 6,400 kWh. The incentive would be approximately \$1,300. This EEM would result in an average annual net COST to Santa Rosa of about \$1,000. The NPV of cumulative annual cost would be \$15,600. The table below shows that installing EEM 8-6 would NOT be cost-effective.

Table 8-12: Summary of EEM 8-6 Replace Beretta South Pump

Electricity Savings (kWh/Yr)	Electricity Savings (\$/1 st Yr)	GHG Emission Reduction (MT/Yr)	Capital Cost (\$)	Incentive Amount (\$)	Avg Annual Net Savings (\$/Yr)	Cumulative Net Savings (\$)	NPV of Cumulative Net Savings (\$)	ROR (%)
6,400	\$750	1	\$30,000	\$1,300	(\$1,000)	(\$20,200)	(\$15,600)	-2.0%

8.6.7 EEM 8-8: Replace Mello East Pump

The 50 HP centrifugal pump was identified as inefficient due to the low (60%) OPE. This EEM would replace the pump with an optimized unit of the same size that could provide an OPE of at least 69%. The existing pump conveyed approximately 23.6 million gallons in the 2016 pumping season.

Capital cost for the new pump would be approximately \$20,000, which is based on a cost of \$400/HP. Engineering costs were estimated to be \$5,000 based on 25% of capital costs. Energy savings from this EEM are about 3,000 kWh. The incentive would be approximately \$1,000. This EEM would result in an average annual net COST to Santa Rosa of about \$1,250. The NPV of cumulative annual cost would be \$18,700. The table below shows that installing EEM 8-8 would NOT be cost-effective.

Table 8-13: Summary of EEM 8-8 Replace Mello East Pump

Electricity Savings (kWh/Yr)	Electricity Savings (\$/1 st Yr)	GHG Emission Reduction (MT/Yr)	Capital Cost (\$)	Incentive Amount (\$)	Avg Annual Net Savings (\$/Yr)	Cumulative Net Savings (\$)	NPV of Cumulative Net Savings (\$)	ROR (%)
3,000	\$360	0	\$25,000	\$1,000	(\$1,250)	(\$25,000)	(\$18,700)	-6.1%

Memorandum

Santa Rosa EOP – Task 2.3 Irrigation System Optimization Investigation

Page 13

8.6.8 EEM 8-9: Replace Matos Cheese Factory Pump

The 30 HP centrifugal pump was identified as inefficient due to the low (55%) OPE. This EEM would replace the pump with an optimized unit of the same size that could provide an OPE of at least 69%. The existing pump conveyed approximately 22 million gallons in the 2016 pumping season.

Capital cost for the new pump would be approximately \$12,000, which is based on a cost of \$400/HP. Engineering costs were estimated to be \$3,000 based on 25% of capital costs. Energy savings from this EEM are about 3,200 kWh. The incentive would be approximately \$1,100. This EEM would result in an average annual net COST to Santa Rosa of about \$500. The NPV of cumulative annual cost would be \$7,300. The table below shows that installing EEM 8-9 would NOT be cost-effective.

Table 8-14: Summary of EEM 8-9: Replace Matos Cheese Factory Pump

Electricity Savings (kWh/Yr)	Electricity Savings (\$/1 st Yr)	GHG Emission Reduction (MT/Yr)	Capital Cost (\$)	Incentive Amount (\$)	Avg Annual Net Savings (\$/Yr)	Cumulative Net Savings (\$)	NPV of Cumulative Net Savings (\$)	ROR (%)
3,200	\$375	0	\$15,000	\$1,100	(\$500)	(\$9,500)	(\$7,300)	-1.8%

8.6.9 EEM 8-11: Control Pumping During Summer On-Peak Periods

This EEM consists of installing controls at each reclamation pump that serves an end user of recycled water. The new controls would prevent the pump from operating during Summer On-Peak rate period from May 1st to October 1st, Monday through Friday, from 12:00 PM to 6:00 PM. This control would cause irrigators to pump during periods when electricity is significantly less expensive.

This EEM would not necessarily result in any reduction in energy consumption or demand, but there would be savings resulting from shifting use to lower priced time periods. Estimating the potential savings from this EEM was beyond the scope of this study. The cost of implementing these controls would be relatively small and could be easily installed by City staff. The energy and demand charges for lower priced periods are approximately half (or less) of the Summer On-Peak rates. Changing irrigation practices in this way could be an inconvenience for some irrigators; however, pumping could still occur during daylight hours that are before and after the on-peak period.

Based on feedback from City staff, this EEM would NOT be feasible because pump size, available irrigation equipment, and the need for irrigation customers to irrigate during daylight hours all limit the ability to irrigate during off-peak hours. Hence, this EEM is not recommended.

June 14, 2017

Final Technical Memorandum #9

To: Mike Prinz, Tasha Wright, and Claire Myers - City of Santa Rosa

From: Alan Zelenka – Kennedy/Jenks Project Manager

Subject: Task 2.4 – Comprehensive Solar PV Investigation

9.1 Goal of this Solar PV Investigation

The goal of this investigation is to provide the City with a high level overview of options for a 1 megawatt (MW) renewable energy installation, including solar photovoltaic (PV) technologies, implementation issues, potential sites, costs, and financing. This investigation is intended to narrow down the numerous options available to the City and provide a roadmap for next steps. By identifying the preferred locations, technologies, and ownership structures the City will be able to focus its efforts on the most cost-effective solar PV projects. The City should use the recommendations from this investigation to establish the next level of detailed investigation into potential solar PV projects.

This technical memorandum:

- Conducts a comprehensive review of all potential city-owned sites and identifies the top five sites for 1 megawatt (MW) solar PV projects.
- For the top five sites, a site evaluation and scoring identifies the preferred site(s).
- Describes and compares ground mounted and floating (floatovoltaics) solar PV technologies, and identifies potential barriers to implementation for both technologies.
- Describes potential ownership and financing structures, including own-and-operate (O&O), purchase power agreement (PPA), and lease.
- Conducts a cost-effectiveness analysis on the preferred site(s) for the various ownership structures.
- Makes recommendations and outlines the next steps for the City to conduct the detailed analysis necessary to implement a solar PV project.

An appendix provides more detailed information on:

- A. Energy production of different types of solar PV systems.
- B. Various solar installation options.
- C. Local solar companies and considerations for when selecting a solar company.
- D. Purchase structures and roles.
- E. Potential solar PV incentives programs.
- F. Existing City-owned solar PV systems.
- G. Maps of the top 5 potential solar PV sites.

9.2 Recommendation Summary

Kennedy Jenks recommends the following:

1. Renewable Energy Measure (REM) 9-5: Further investigate the Pond Lease option with Ciel & Terre for a 1 MW photovoltaic solar PV system on one of the City's reclamation ponds. Because this option is low risk, has very little upfront capital cost, and can be an easy entree into larger scale solar PV projects, this option deserves serious consideration by the City.
2. REM 9-4: Further investigate a PPA for a 1 MW photovoltaic on Pond B, and determine if it can be cost-effectively interconnected with the LTP allowing it to be "behind-the-meter" to take advantage of the higher average LTP rate compared to the lower NEM or RES-BCT rates.
3. REM 9-3: Further investigate the development of a 1 MW ground mounted solar PV system with a PPA at 4220 Walker Avenue, Santa Rosa. Determine whether the site can be cost-effectively interconnected with the LTP allowing it to be "behind-the-meter" to take advantage of the higher average LTP rate compared to the lower NEM or RES-BCT rates. Determine if the California Tiger Salamander (CTS) issues on this site can be resolved for less than \$900,000 (the estimate in this analysis).

The analysis leading to these findings is provided in the following sections. In addition, thirteen detailed Next Steps are described in Section 9.17.

9.3 Declining Cost of Solar PV

The price of individual solar panels (as opposed to installed complete solar systems) has continued to drop over the past few decades as can be seen from Figure 1. While there was a dramatic decline in the price of solar panels throughout the 1980s, the price leveled off through the 1990s and 2000s. Recently, because of improvements in solar cell efficiencies and a tremendous increase in the supply of solar panels from Japan, Korea and China, the price has dropped significantly.

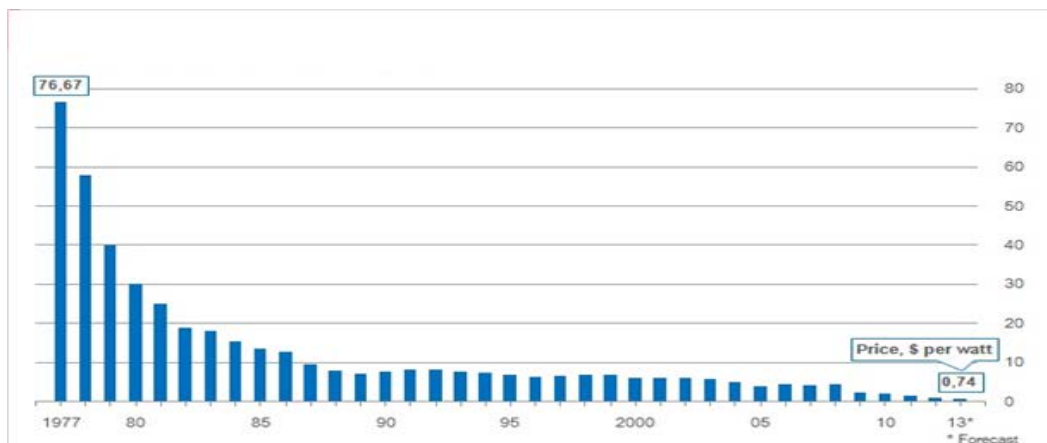

Source: Solar Power Now <http://solar-power-now.com/cost-of-solar/cost-of-solar-panels/>

Figure 1 – Price of Solar PV Panels (\$ per Watt)

Completely installed residential solar PV systems¹ have also seen a corresponding dramatic drop in price over the past 5 years (see Figure 2). According to the Go Solar California website (<http://www.gosolarcalifornia.ca.gov/>), as of December 2016 there were over 580,000 solar PV installations in California generating over 4,500 MWs. In 2016, the average price of installed systems less than 10 kilowatt (kW) was \$5.27 per Watt; systems greater than 10 kW were \$4.37 per Watt. For large 1 MW direct current (DC) solar PV systems the installed price has also been dropping from \$2.50 per Watt in 2013 to below \$2.00 per Watt in 2016. Larger sized utility-scale systems (> 5MW) are seeing installed prices in the range of \$1.50 to \$1.75 per Watt installed. This precipitous drop in prices now makes solar PV projects significantly more cost-effective.

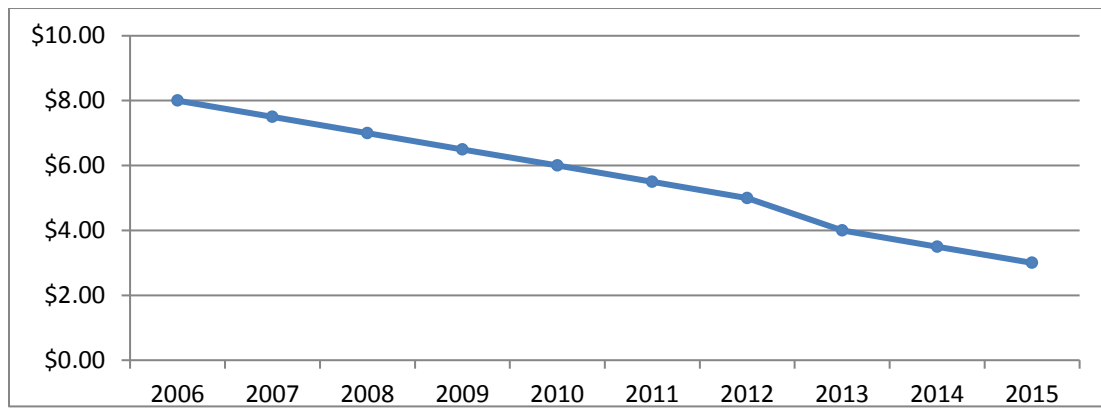

Source: Solar Power Now <http://solar-power-now.com/cost-of-solar/cost-of-solar-panels/>
 Figure 2 - Installed Cost per Watt for Residential Systems

9.4 Site Evaluation

City staff provided Kennedy/Jenks a list of 33 City-owned properties to assess as potential solar PV project sites. Each site was evaluated based on the following criteria:

- Size and physical characteristics of the site, and suitability for solar installations.
- Whether the site is located within a 100-year or 500-year flood zone.
- Potential to cause environmental impacts on habitat for CTS and Meadow Foam, or impact wetlands.
- Current or planned public uses, such as recreational areas.
- Use by the Laguna Treatment Plant.
- Current or planned commercial use of the site such as a working farm.
- Under consideration for mitigation bank.
- Ownership and lease issues.

¹ Complete solar PV systems include: solar PV panels, inverters, mounting racks, site prep, installation, electric connections, and developer markup and profit.

Final Technical Memorandum #9
 Santa Rosa EOP – Task 2.4 Solar PV Investigation
 Page 4

Based on the results of this evaluation, five sites emerged as the top potential sites. These are listed in Table 1.

Table 1: Top Five Potential Solar PV Project Sites

APN #	Parcel Acres	Project Acres	Address	Type of PV System	Nickname	Notes
134-232-035	7.1	5.9	4220 Walker Ave	Ground Mount	4220 Walker	close to LTP, lease expires 2019, potential CTS critical habitat
063-180-025	154.4	4.4	4301 Llano Rd	Flotovoltaics	Pond B	close to LTP, the use of flotovoltaics should not interfere with system operation
130-040-008	115.9	52.3	727 Willowside Rd	Flotovoltaics	Delta Pond	the use of flotovoltaics should not interfere with system operation
134-232-012	18.0	10.6	4030 Walker Ave	Ground Mount	4030 Walker	close to LTP, lease expires 2019, potential CTS critical habitat
134-232-025	7.3	4.6	No address (east of Walker Ave and north of Schuler)	Ground Mount	Karcher	close to LTP, lease expires 2019, potential CTS critical habitat

Table 2 shows the other sites evaluated and eliminated from consideration. The table includes the reason(s) for elimination.

Table 2: Sites Eliminated from Consideration

APN #	Acres	Address	Nickname	Reason(s) for Elimination
060-010-027	17.5	5420 Occidental Rd	Kelly	Laguna open space trail/easement, being considered for mitigation bank, CTS critical habitat
060-010-032	21.5	None	Kelly	Laguna open space trail/easement, flooding, existing road and buildings, size (only 1 acre usable), being considered for mitigation bank, CTS critical habitat
060-020-001	100.0	5140 Occidental Rd	Kelly	being considered for mitigation bank, CTS critical habitat
060-020-081	46.1	None	Kelly	CTS critical habitat, being considered for mitigation bank
060-020-082	58.3	6050 Sebastopol Rd	Kelly	proximate to Laguna open space trail, public visibility, under consideration for CTS mitigation bank

Final Technical Memorandum #9
 Santa Rosa EOP – Task 2.4 Solar PV Investigation
 Page 5

APN #	Acres	Address	Nickname	Reason(s) for Elimination
060-020-085	41.6	5950 Sebastopol Rd	Kelly	proximate to Laguna open space trail, public visibility, under consideration for CTS mitigation bank
060-050-038	10.0	3020 Llano Rd	Tree farm	cost of tree removal, biological species concerns
060-060-007	10.1	2927 Llano Rd	Lee	existing working farm
060-060-044	13.7	2505 Llano Rd	LaFranconi/Brown	flood zone, wetlands, size
060-330-010	0.3	5740 Occidental Rd	Stone	flood zone, public visibility, size
060-330-011	10.5	5750 Occidental Rd	Stone	flood zone, public visibility
062-240-025	84.5	4300 Llano Rd	LTP	damage to Flow Equalization Basin lining, size
063-180-009	30.5	4101 Llano Rd	LTP (part of 4301)	usable space, orientation
130-020-030	12.7	4789 Hall Rd	Ambrosini pond	flood zone, public visibility
130-250-014	46.9	6001 Occidental Rd	Stone	flood zone, creek
130-250-049	48.1	5750 Occidental Rd	Stone	flood zone, creek, public visibility
130-250-050	6.3	None	Stone	flood zone, creek, public space
134-231-014	1.0	None		flood zone, possible mitigation bank, size
134-231-015	2.1	4055 Walker Ave	4055 Walker	flood zone, possible mitigation bank, onsite housing and buildings, size
134-232-031	9.5	4164 Walker Ave	4164 Walker	existing nursery with buildings, size
134-232-041	2.3	4322 Walker Ave	4322 Walker	flood zone, wetlands, size, existing buildings
134-232-042	7.6	4284 Walker Ave	4284 Walker	flood zone, wetlands, size
060-060-051	121.5	3000 Llano Rd	Alpha	flood zone, creek, potential biosolids application location
060-060-052	307.3	3110 Llano Rd	Alpha	flood zone, creek, biosolids application location
060-060-059	136.2	2200 Llano Rd	Brown	flood zone, meadow foam, vernal pool, potential biosolids application location
060-060-060	0.0	2200 Llano Rd	Brown 2 West	flood zone, open space along walking path, potential biosolids application location
134-232-010	9.8	4136 Walker Ave	4136 Walker	creek

Figure 3 provides a map of the top five potential sites. Detailed maps of the individual sites are included in Appendix G.

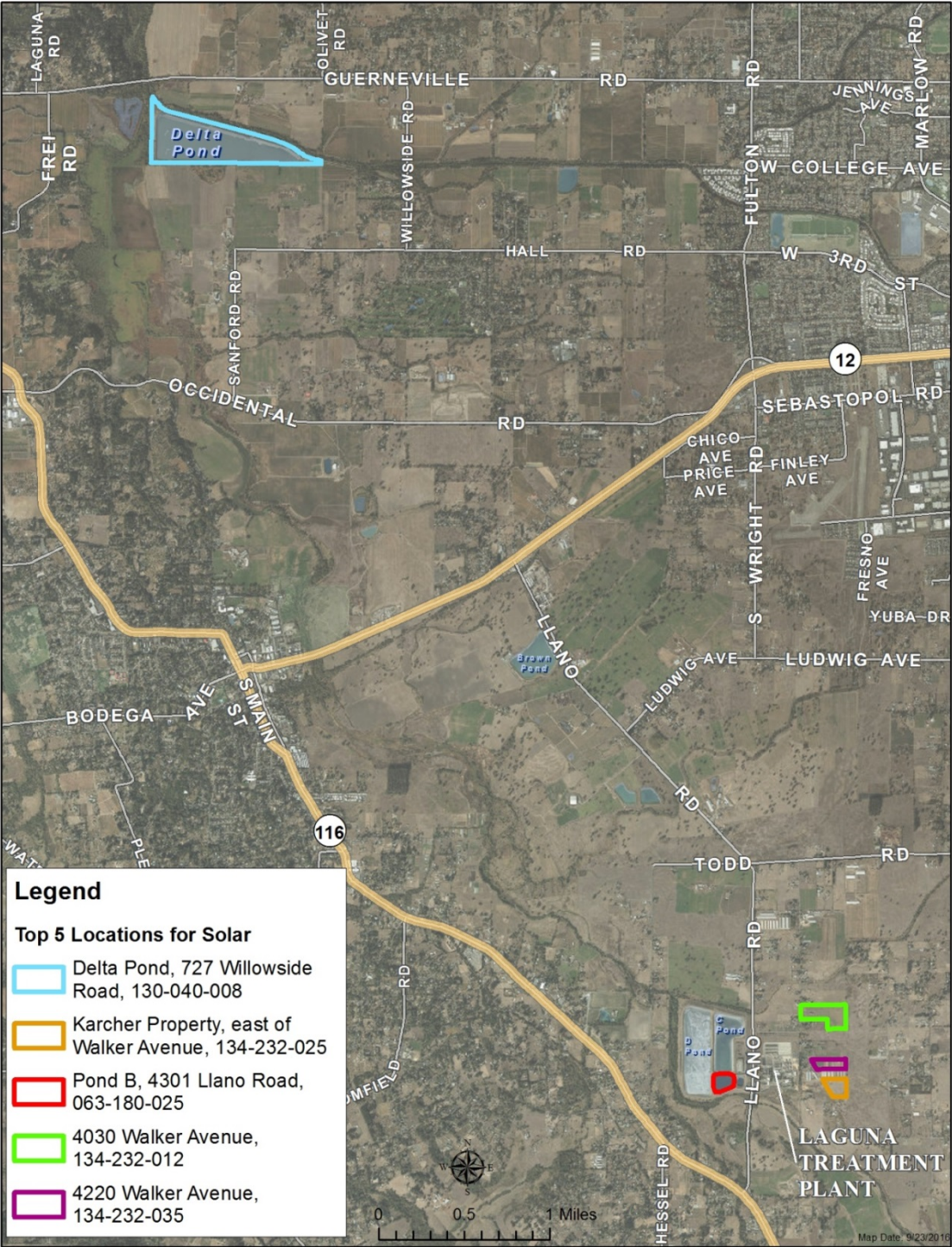

Figure 3: Map of the Top 5 Potential Solar PV Sites

9.5 Siting Criteria and Constraints

To score and rank the top five sites for solar PV project development, Kennedy/Jenks and the City used siting criteria to evaluate each site:

1. **Solar Resource.** Does a site have a sufficient solar resource? The optimal site should be an unshaded, south-facing parcel. Regional climate and project location (latitude) also affect the available solar resource. Lack of a sufficient solar resource would be a fatal flaw for the site, therefore for this criterion sites either pass or fail, and are not scored.
2. **Size, Location, and Land Use.** This analysis conservatively assumes that 5 acres of land are required for each MW of a fixed-tilt solar PV project and 3 acres of pond surface for each MW of flotovoltaics, although the exact size depends upon the type of technology selected.

The location of the site should be considered relative to electricity loads. It is preferable to locate a project next to a significant electric demand so that it can be interconnected and become “behind the meter” to take advantage of higher rates.

Land use for solar is not very restrictive, since a solar project can be sited on rooftops, parking garages, ponds, and tanks. For this analysis, all of the top five sites are a reclamation pond or a vacant parcel being used for agriculture. However, construction of solar facilities would prevent the land from being used for other City purposes for the life of the solar project. The score for a given parcel is reduced if the site is being considered for an alternate use (e.g., for biosolids application).

3. **Operational Impacts.** A solar PV project can impact Subregional operations if it causes City staff to alter their operations, or if it adds additional cost and complexity to operations. If the solar PV project is on vacant land not normally used by Subregional personnel, there would not be an impact. If the solar PV project were floating on a storage pond and it would alter the way the City would use or operate the pond, then the impact could be moderate to significant.
4. **Sensitive Neighbors.** Visual, noise, and vandalism concerns should be considered for all alternative energy projects, in particular in relation to viewers in publicly accessible recreational areas such as trails, scenic roadways, and residential neighborhoods. Potential impacts can sometimes be mitigated with setbacks for transformers/invertors, security fencing, and site screening.
5. **Sensitive Environment.** Each site is considered for proximity to sensitive environments or species that could be disturbed by construction activities or continued shading from a solar PV project. Critical habitat for CTS, an endangered species, is prevalent on City-owned properties near the LTP; CTS breeding grounds and wetlands must be avoided entirely, and any disturbance to CTS critical habitat would need to be mitigated.
6. **Constructability.** Constructability, accessibility, or unusual site conditions can impact a site’s attractiveness. Projects are easier to construct on flat parcels. Proximity to roads and/or rail lines provides easier access for equipment installation and maintenance. Other constructability issues may include subsurface soil conditions and site drainage requirements. Access to the pond will impact constructability.

9.6 Site Scoring Metrics

Scoring metrics were developed for the above siting criteria to categorize each site as Good, Fair, or Poor. A numeric score was assigned to each criterion; a 1 is the lowest or least favorable score (Poor) and 5 is the highest or most favorable score (Good).

A “stoplight” color scale is used to visually identify highly scored sites. A poor score shown in red may indicate a fatal flaw. The metrics for each criterion are summarized in Table 3.

Table 3: Site Scoring Metrics for Solar PV

Criterion	Good = 5	Fair = 3	Poor = 1
Solar Resource	Unshaded, south-facing parcel	Parcel may be partially shaded, west or east facing	Shaded, north-facing
Size, Location, Land Use	Not likely to interfere with future land use, adjacent to significant load	Ties up land for possible future City use, not located near a significant load	Ties up land for known future City use, not located near a significant load
Operational Impacts	No alteration in operations nor additional costs	Causes modest impact on operations and slightly increases cost	Makes operations much more difficult and increases cost substantially
Sensitive Neighbors	Few sensitive viewers, not likely to express concern	Sensitive viewers nearby that may require screening	Solar project would disturb a scenic view or would be visible to a large number of sensitive viewers
Sensitive Environment	No sensitive species	Possible sensitive species	Known endangered or protected species on site
Constructability	Flat slope, easily accessible from road, easily accessible pond	Sloped site, mediocre access, vegetation cover, or other minor site constraints, minor pond access issues	Steep site with significant constructability concerns, difficult to access, poor soils, or other major site constraints, poor pond access

9.7 Siting Evaluation Matrix

The siting criteria and metrics listed in Table 3 were applied to each of the top five potential sites. Table 4 provides a detailed description of the site evaluation results, and Table 5 presents the scores. Kennedy/Jenks applied the siting criteria and the scoring of each site in coordination with City staff.

Table 4: Description of Site Evaluation for Top Five Potential Sites

Site	Solar Resource	Size, Location, Land Use	Operational Impacts	Sensitive Neighbors	Sensitive Environment	Constructability
4220 Walker	Moderately sized relatively flat parcel with no shading	This site is not likely to be used for future expansion or use, and is located near significant load at LTP	Location is sufficiently out of the way and will not impact operations	Project would be within the viewshed of nearby homes	Potential CTS critical habitat requiring mitigation	Flat site would require minimal site work
Pond B	Sufficiently large south facing pond with no shading	Existing storage pond located within LTP facilities	Flotovoltaics may impact operations when the ponds level fluctuates, and would be in the way if maintenance is required on the pond liner	Pond is contained within existing boundary of LTP with no sensitive viewers	None known; unlikely since already an operating storage pond	Flotovoltaic anchors to the pond shore, does not impact the integrity of the pond; may be more difficult to construct than ground mount systems, and fewer vendor options are available
Delta Pond	Large south facing pond with no shading	Existing storage pond not located near a significant load	Flotovoltaics may impact operations when the ponds level fluctuates, and would be in the way if maintenance is required on the pond liner	Views of Pond from public roadways and residences are generally screened by intervening vegetation and topography	None known; unlikely since already an operating storage pond	Flotovoltaic anchors to the pond shore, does not impact the integrity of the pond; may be more difficult to construct than ground mount systems, and fewer vendor options are available
4030 Walker	Large south facing parcel with no shading	This site is located near significant load at LTP; it is being considered for future projects that may or may not be compatible with solar	Location is sufficiently out of the way and will not impact operations	Project would be within the viewshed of nearby homes	Potential CTS critical habitat requiring mitigation	Flat site would require minimal site work
Karcher	Medium-size west facing parcel with no shading	This site is not likely to be used for future expansion, and is located near significant load at LTP	Location is sufficiently out of the way and will not impact operations	Project would be within the viewshed of nearby homes	Potential CTS critical habitat requiring mitigation	Flat site would require minimal site work

Table 5: Site Evaluation Scores for Potential Sites

Site	Solar Resource	Size, Location, Land Use	Operational Impact	Sensitive Neighbors	Sensitive Environment	Constructability
4220 Walker	Pass	5	5	3	1	5
Pond B	Pass	5	4	5	5	4
Delta Pond	Pass	4	4	5	5	4
4030 Walker	Pass	3	5	3	1	5
Karcher	Pass	5	5	3	1	5

9.8 Site Weighting and Ranking

Once the criteria evaluations were completed, Kennedy/Jenks worked with City staff to develop the weighting for the criteria (Table 6). The weighting was then applied to each criterion to create a total score to rank the sites from most to least favorable.

Table 6: Weighting of Scoring Criteria

Criterion	Weighting
Solar Resource	Pass/Fail
Size, Location, Land Use	20%
Operational Impact	25%
Sensitive Neighbors	10%
Sensitive Environment	20%
Constructability	25%

The sites, ranked by final score, are shown in Table 7. Stoplight color coding visually shows how the alternatives rank, with more favorable options shown in green and less favorable sites shown in yellow.

Table 7: Site Scoring and Ranking

Site	Score	Rank
Pond B	4.5	1
Delta Pond	4.3	2
4220 Walker	4.0	3
Karcher	4.0	3
4030 Walker	3.6	5

9.9 Preferred Site Recommendations

The highest-ranking site is Pond B. It out-scored Delta Pond because of its proximity to the LTP making it the only site that is “behind the meter” at LTP, meaning it can take advantage of the higher Net Metering incentive compared to the lower RES-BCT incentive. Pond B out-scored the land-based sites because of their potential impact on CTS critical habitat, and the fact that they may be in the viewshed of nearby homes.

Of the land-based sites 4220 Walker and Karcher had the same score. They scored higher than 4030 Walker because it is being considered for future projects that may or may not be compatible with a solar project.

9.10 Solar PV Installation Options

This analysis considers two solar PV installation options: ground-mounted and floating (or flotovoltaic). Ground-mounted solar PV is the traditional approach to solar project development whereby the panels are deployed on structures at a fixed tilt angle. Ground mounted systems are well tested and commonly installed. Fixed tilt installations are what the City has installed to date. For this analysis, we used recent cost estimates from Solar City for a 1 MW system installed on City property.

A new type of installation configuration mounts the solar PV panels on pontoons floating on a pond, otherwise known as “flotovoltaics.” Floating solar systems have the potential to be cost-effective while utilizing pond surfaces for the installation in lieu of relatively valuable land surfaces. Numerous environmental impacts studies have been done on flotovoltaic systems and they conclude there are no deleterious impacts from the system. In fact, the studies show that there are several co-benefits of these systems: they reduce water evaporation, reduce algae growth resulting in lower chemical treatment costs, and they reduce pond wave action which reduce shores erosion. However, they are new, and as of yet there are no large scale systems operating in the US. For this analysis, we used recent cost estimates from Ciel & Terre, a French company with a new US subsidiary headquartered in near-by Petaluma, California.

A more detailed discussion of solar PV installation options can be found in Appendix B.

9.11 Ownership Structures

The City could pursue a solar PV project through three different purchase structure options:

1. **Own and Operate (O&O):** The City would purchase a solar PV system using its capital, install the system on its property, and use the City staff to operate the system. Capital would come from City reserves, or through a financing mechanism such as a bond.
2. **Power Purchase Agreement (PPA):** A third party would finance, own, and operate the solar PV system, and the City would purchase the power generated from the third party. This could be an advantage for the City because of no upfront capital costs and the availability of tax credits to a third party which could be rolled into the pricing for the City².

² Tax-exempt entities such as the City are not eligible for tax credits under an own and operate system. Under a PPA agreement, tax savings to a third party could, however, be rolled into the pricing under the agreement.

Final Technical Memorandum #9
 Santa Rosa EOP – Task 2.4 Solar PV Investigation
 Page 12

3. **Lease:** The City would lease its land or a pond to a solar power developer and benefit from lease payments. The City would not use or purchase any of the power generated at the site.

A summary and comparison of the pros and cons of these ownership structures is presented in Table 8.

Table 8: Ownership Structure Summary and Considerations

Ownership Structure	Summary Description	Pros	Cons
Own and Operate (O&O)	The City would purchase a solar PV system using its capital, install the system on its property, and use City staff or a third-party contractor, to maintain the system	<ul style="list-style-type: none"> Higher financial reward 	<ul style="list-style-type: none"> Risk of system under-performance is responsibility of the City The City is responsible for all costs of ownership
Power Purchase Agreement (PPA)	A third party would finance, construct, own and operate the solar PV system; the City would purchase the power generated from the third party	<ul style="list-style-type: none"> Risk of system under performance responsibility of the third party No upfront capital cost for the City No operations and maintenance for the City Potential for PPA price that lowers the City's energy costs 	<ul style="list-style-type: none"> Lower reward because third-party applies a risk premium to compensate for system under-performance risk Risk of PPA firm stability Risk of signing a complex contract
Lease	City would lease land or a pond to a solar company to develop a solar project for sale to the utility	<ul style="list-style-type: none"> Lease payments No operational concerns or risks Reduce water evaporation and bank erosion 	<ul style="list-style-type: none"> No renewable energy added to the City's energy portfolio, nor any reduction in GHGs

These purchase structures are discussed in more detail in Appendix D.

Previously the City used the own and operate structure with a design/build contract. The City used to perform all the O&M for its existing solar facilities, but recently contracted out for selective cleaning and maintenance for several existing systems.

9.12 Sonoma Clean Power Impacts on Solar Projects

9.12.1 Description³

In 2002, Assembly Bill 117 enabled communities to “purchase power on behalf of their residents and businesses, creating competition in power generation, supporting lower prices and accelerating the development of local renewable power generation.” Sonoma Clean Power (SCP), the Community Choice Aggregation (CCA) entity for Sonoma County, came online in 2014. SCP is a not-for-profit agency, independently governed by the Board of Directors of the Sonoma Clean Power Authority, a joint powers authority of the County and the cities that have voted to join. The Board is advised by a public Community Advisory Committee. In 2017 the Board voted to approve service to Mendocino County.

SCP offers its customers the option of using power generated by cleaner and renewable sources, including wind and geothermal at competitive rates, with the possibility of adding solar, biomass, and eligible hydropower. As of 2015, 36% of SCP’s default CleanStart service is from renewable sources, as compared to PG&E which obtains approximately 30% of its energy from renewable sources. SCP also offers an “EverGreen” option, consisting of 100% local renewable geothermal power.

9.12.2 GHG Emissions

SCP’s energy resource portfolio was designed to increase the percentage of renewable power and create fewer GHG emissions when compared to PG&E. In 2015 (the most recent year for which data is available) SCP’s CleanStart portfolio emitted approximately 218 metric tons of carbon dioxide (MT CO₂) per MWh of energy produced, and the EverGreen portfolio emitted 57 MTCO₂/MWh. In comparison, PG&E’s electricity emitted on average 405 MT CO₂ per MWh of energy produced⁴. The City purchases its electricity from SCP; this will result in fewer reductions of GHGs by constructing solar than if the City purchased its electricity from PG&E.

9.12.3 Rates

For most customer rate categories, rates for SCP are slightly below PG&E’s. For other project investigations it was assumed that the PG&E rates would escalate at about 4% per year; while it is unclear what the escalation rate for SCP will be over the next 20 years we assumed it would escalate at the same 4% rate.

³ The description is derived from the SCP website <http://sonomacleanpower.org>

⁴ Sources: SCP, 2016a. PG&E – SCP Comparison. Electric Power Generation Mix. Available at: <http://sonomacleanpower.org/about-scp/power-sources/>

SCP, 2016b. Sonoma Clean Power, 2014-2015 Annual Report. Available at: <http://sonomacleanpower.org/flipbooks/SCPAnnual2014-2015/>

PG&E, 2015. Greenhouse Gas Emission Factors: Guidance for PG&E Customers November 2015. PG&E’s 2015 Electric Power Mix was comprised of approximately 30% renewable sources (<http://www.pge.com/en/about/environment/pge/cleanenergy/index.page>). 457 MT CO₂ is the average of the last five years of historical emissions

9.13 Incentives

There are two main incentive programs that the City could take advantage of depending on which ownership structure is used.

9.13.1 Net Energy Metering (NEM)

Net Energy Metering (NEM) is a program that applies to solar projects that are intended for the onsite use of the generated energy (sometimes referred to as being “behind the customer meter”). NEM is a utility rate tariff that allows customers to generate their own electricity, export any excess electricity to the grid, and get credited for the excess energy produced. Effectively, the meter can run backwards, causing a credit with the utility. The City does not have to own the eligible renewable resource; however, the output must be dedicated to offset the electricity used at that onsite meter. NetGreen is Sonoma Clean Power’s NEM program. For this analysis we estimated the offset electric rate by using the average rate for the LTP (\$0.1155/kWh calculated from data provided by the City for the period October 2015 – September 2016 under the Clean Start and E-20 rate schedules), applying a reduction of \$0.023/kWh because of the NEM 2.0 rules changes, and applying another reduction of 20% to account for solar project’s inability to fully offset demand charges. We estimate that this makes the NEM rate about 64% of the average LTP rate or \$0.074/kWh.

9.13.2 Renewable Energy Self-Generation Bill Credit Transfer (RES-BCT)

The Renewable Energy Self-Generation Bill Credit Transfer (RES-BCT) program allows local governments (such as the City) and special districts to install renewable generation of up to 5 MW at one location within its geographic boundary, and to obtain credits that can be used to offset the generation energy charges at one or more (up to 50) other benefiting accounts within the same geographic boundary. Unlike NEM, RES-BCT credits the City with ONLY the generation energy charges portion of their utility rate schedule/tariff (and not the generation demand, distribution, transmission or other charges from the rate schedule/tariff - the City will still pay those charges and fees). Therefore, the incentive rate is lower than regular NEM program. We estimate, based on reviewing previous solar project pro formas, that this makes the RES-BCT rate about 50% of the average LTP rate or \$0.0577/kWh.

Recommendation: The City should conduct a detailed cost/benefit analysis to determine the NEM and RES-BCT rates and credits for a potential solar project, which is beyond the scope of this analysis, and that analysis should include:

- ***NEM 2.0 rate reductions.***
- ***The applicable TOU rate structure.***
- ***The inability of a solar project to fully offset demand charges.***
- ***Modelling of specific solar project hourly output and calculation of the RES-BCT credit (by applying the corresponding TOU period generation component of the energy charge for the applicable rate tariff).***
- ***Compare the benefits associated with different rate structures (e.g., E-20 vs A-6), and determine if the preferred solar sites can use the rate with the higher credit benefit (i.e., the A-6 rate).***

- **Conduct a sensitivity analysis on potential changes to the TOU structure.**

These incentive programs, as well as a more comprehensive list of potential incentive programs, are discussed in more detail in Appendix E.

9.14 Cost-Effectiveness Analysis

The cost-effectiveness of the following four options was calculated:

1. REM 9-1 and 9-2: Owned and operated turnkey design/build ground mounted system, using both the NEM and RES-BCT incentives.
2. REM 9-3: PPA contract for a ground mounted system.
3. REM 9-4: PPA contract for a flotovoltaic system on a storage pond.
4. REM 9-5: Pond surface lease.

Recommendation: While this analysis reports results for a fixed tilt solar PV system, it is also recommended that the City further investigate and compare the cost-effectiveness of single-axis tracking solar equipment which is beyond the scope of this analysis. Depending on the system and the cost, tracking single-axis systems can be as much as one cent per kWh lower in cost when compared to a fixed tilt system.⁵

Finally, this analysis assumes a 1 MW project⁶. While a larger project does provide some economies of scale, solar developers note that PPA prices do not reduce until a solar PV project reaches about 5 MWs.

The common term for solar PPA is 25 years, and this analysis uses a 25 year bond term to calculate the debt service. However, since the reported results for all of the other Energy Optimization Plan projects used a 20 year period, we will provide results for a 20 year period to allow an apples-to-apples comparison to other EOP projects, and also results for a 25 year period to allow comparisons to other solar PV projects.

The cost estimates provided in this analysis are based on the Association for the Advancement of Cost Engineering International (AACEI) standards for cost estimating accuracy of +50% and -30%.

9.14.1 REM 9-1 and 9-2: Owned and Operated Turnkey Design/Build Ground-Mounted System Using Either the NEM or RES-BCT Incentive

Under REM 9-1, the City would own and operate a ground-mounted solar PV project adjacent to LTP using the utility's NEM program to interconnect the PV system to the facility's energy meter. Under REM 9-2, the City would use the utility's RES-BCT program to interconnect the system.

Capital costs would include the PV panels, inverters, wiring, engineering, installation, internal electric connection, utility grid interconnection, warranty, and a performance monitoring and reporting service.

⁵ Fixed Tilt system generation starts at 1,441,800 kWh/year, and a Single-Axis Tracking system generation starts at 1,765,900 kWh/year; approximately 23% more electricity generation.

⁶ 1 MW size project was chosen because it is the common choice for solar company offers, mostly because of the previous Net Metering program limitation of project sizes to 1 MW; , and it would not require a Rule 21 interconnection study.

The lifetime of most PV arrays is up to 30 years, and failures that require replacements are rare and are usually covered by the warranty. PV arrays degrade at a rate of approximately half of one percent (0.5%) of total system capacity per year. The inverter needs to be replaced every 15 years, and this cost can be included in a vendor maintenance agreement.

A 1 MW solar PV system was modelled with the following assumptions:

- A turnkey design/build installed price of \$2.56/Watt (\$2.56 million for a 1 MW system).
- Paid for using a 25 year 4% bond.
- The solar project would offset the LTP average rate for 2016 which is \$0.1155/kWh escalating at 4% per year; the NEM rate is \$0.074/kWh, and the RES-BCT rate is \$0.0577/kWh.
- To qualify for NEM the system would need to be interconnected to the LTP, so we assume about \$250,000 to create the intertie to LTP.
- To qualify for RES-BCT rate the City must also conduct a Rule 21 interconnection study, so we assumed \$25,000 for the study.
- No CSI incentive is available.
- Generation is 1,441 kWh/kW/year.
- Panel performance degrades at 0.5% per year. The degradation of the system capacity begins at year 1 and continues throughout the system lifetime. Manufacturer warranties usually take this degradation into account.
- First year generation is 1,441,800 kWh decreasing to 1,278,100 after 25 years.
- Replacement of the inverter in year 15 at a cost of \$200,000.
- Internal project development costs associated with contract administration, legal, and procurement process (estimated at \$100,000).
- California Environmental Quality Act (CEQA) document and permitting fees (estimated at \$250,000).
- Mitigation credits for CTS of approximately \$130,000 per disturbed acre (estimated at \$650,000 for 5 disturbed acres).
- System maintenance of approximately one hour per week, plus a contract for \$15,000 per year through a solar vendor. Regular maintenance is minimal over the life of the system and includes periodically washing and cleaning the panels, as well as testing and cycling the inverters.

The results of the cost-effectiveness analysis on these options, shown in the table below, are that they would result in a net cost to the City. However, the solar projects using the NEM incentive (REM 9-1) would be cost-effective (a positive NPV) if it were not for the \$900,000 additional cost for the CTS mitigation and the CEQA study. REM 9-2, the RES-BCT project, would still result in a net cost to the City even without the additional CTS mitigation and CEQA study costs, and this is

Final Technical Memorandum #9
 Santa Rosa EOP – Task 2.4 Solar PV Investigation
 Page 17

because the assumed RES-BCT rate is lower than the NEM rate resulting in a lower credit for the project.

Table 9: Summary of REM 9-1 and 9-2 - Ground Mounted Own and Operate Solar Project

	Incentive Type and Analysis Period (Yrs)	Average Electricity Savings (kWh/Yr)	First Year Savings (\$/Yr)	GHG Emission Reduction (MT/Yr)	Capital Cost (\$)	Average Annual Net Savings (\$/Yr)	Cumulative Net Savings (\$)	NPV of Cumulative Net Savings (\$)	IRR (\$)
REM 9-1	NEM-25 Yrs	1,357,700	(\$97,314)	146	\$3,810,000	(\$19,500)	(\$487,900)	(\$543,300)	3%
	NEM-20Yrs	1,357,700	(\$97,314)	146	\$3,810,000	(\$43,700)	(\$874,500)	(\$658,700)	1%
REM 9-2	RES-BCT-25 Yrs	1,357,700	(\$166,000)	146	\$3,585,000	(\$179,300)	(\$4,483,000)	(\$3,053,100)	-6%
	RES-BCT-20 Yrs	1,357,700	(\$166,000)	146	\$3,585,000	(\$178,800)	(\$3,577,100)	(\$2,604,000)	-9%

9.14.2 REM 9-3: PPA Contract for a Ground-Mounted System

Under a PPA structure, the City would enter into a PPA with a third-party solar developer that would own and operate the solar PV project.

Some upfront costs may be required for contract negotiations. Ongoing monitoring of the maintenance contract and the energy production is estimated to require minimal City staff time (approximately 4 hours per month).

Based on recent information provided by SolarCity, a 1 MW PPA solar PV system was modelled with the following assumptions:

- 25 year PPA contract term. There is a possibility of a “lease-buyout” of the contract after 10 years, but that would need to be negotiated with the solar company.
- PPA price of \$0.09/kWh with a 0% annual escalator, meaning the price stays flat for the term of the contract. (Source: price quote from Solar City for a 1 MW system in May 2016.)
- The solar project would offset the LTP average rate for 2016 which is \$0.1155/kWh escalating at 4% per year.
- To allow the project to be “behind-the-meter” the system would need to be interconnected to the LTP, so we assume about \$250,000 to create the intertie to LTP.
- No CSI incentive is available, but the vendor would accrue the Federal Investment Tax Credit.

Final Technical Memorandum #9
 Santa Rosa EOP – Task 2.4 Solar PV Investigation
 Page 18

- Generation is 1,441 kWh/kW/year.
- Panel performance degrades at 0.5% per year.
- First year generation is 1,441,800 kWh decreasing to 1,278,100 after 25 years.
- Replacement cost of the inverter in year 15 (at a cost of \$200,000 in the Own and Operate option) would be covered by the solar vendor.
- Internal project development costs associated with contract administration, legal, and procurement process (estimated at \$100,000).
- California Environmental Quality Act (CEQA) document and permitting fees (estimated at \$250,000).
- Mitigation credits for CTS of approximately \$130,000 per disturbed acre (estimated at \$650,000 for 5 disturbed acres).
- System maintenance would be covered under the PPA contract.

The results of the cost-effectiveness analysis for this option is that the average annual net savings is about \$52,000 per year, the cumulative net savings over 25 years is \$1.3 million, the Net Present Value of the Cumulative Annual Net Savings is \$0.652 million, and the Rate of Return (IRR) is 7%.

Table 10: Summary of REM 9-3 - Ground Mounted PPA Solar Project

Analysis Period (Yrs)	Average Electricity Savings (kWh/Yr)	First Year Savings (\$/Yr)	GHG Emission Reduction (MT/Yr)	Capital Cost (\$)	Average Annual Net Savings (\$/Yr)	Cumulative Net Savings (\$)	NPV of Cumulative Net Savings (\$)	IRR (%)
25 Yrs	1,357,700	\$46,500	146	\$1,250,000	\$52,300	\$1,307,200	\$651,900	7%
20 Yrs	1,357,700	\$46,500	146	\$1,250,000	\$27,200	\$544,600	\$275,600	4%

The savings from a PPA contract depends on numerous factors, and one of the key variables is the PPA price (\$/kWh) over 25 years. The table below shows that the savings decline as the PPA price goes up; the breakeven price is \$0.1176/kWh (meaning the project is no longer cost-effective).

Table 11: Results for Different PPA Prices for REM 9-3 - Ground-Mounted Solar Project

PPA Price (\$/kWh)	Average Annual Net Savings (\$/Yr)	Cumulative Net Savings (\$)	NPV of Cumulative Net Savings (\$)	IRR (%)
\$0.09	\$52,300	\$1,307,200	\$651,900	7%
\$0.10	\$38,700	\$967,800	\$416,200	6%
\$0.11	\$25,100	\$628,300	\$180,600	5%
\$0.12	\$11,500	\$288,900	(\$55,000)	3%

9.14.3 REM 9-4: PPA Contract for a Flotovoltaic System on a Storage Pond

Based on recent information provided by Ciel & Terre a 1 MW flotovoltaic solar PV system with a PPA is modelled with the following assumptions:

- 25 year PPA contract term. There is a possibility of a “lease-buyout” of the contract after 10 years, but that would need to be investigated further and then negotiated with the solar company.
- PPA price of \$0.111/kWh, with a 1.5% annual escalation. (Source: example price provided to the City by Ciel & Terre, October 6, 2016, for a 5 MW system.)
- The solar project would offset the LTP average rate for 2016 is \$0.1155/kWh escalating at 4% per year.
- To allow the project to be “behind-the-meter” the system would need to be interconnected to the LTP, so we assume about \$100,000 to create the intertie to LTP.
- No CSI incentive, but the vendor would accrue the Federal Investment Tax Credit.
- Generation is 1,441 kWh/kW/year. (Note: the estimate provided by Ciel & Terre was 1,775 kWh/kW/year and is 23% higher than the estimate used for this analysis.)
- Panel performance degrades at 0.5% per year.
- First year generation is 1,441,800 kWh decreasing to 1,278,100 after 25 years.
- Replacement cost of the inverter in year 15 (at a cost of \$200,000 in the Own and Operate option) would be covered by the solar vendor.
- Internal project development costs associated with contract administration, legal, and procurement process (estimated at \$100,000).
- Because the solar systems would be placed on a pond the \$900,000 for the CTS mitigation and CEQA study would not be required. This provides a significant cost advantage to any ground mounted system the City should try and develop.
- System maintenance would be covered under the PPA contract.

Final Technical Memorandum #9
 Santa Rosa EOP – Task 2.4 Solar PV Investigation
 Page 20

The results of the cost-effectiveness analysis for this option is that the average annual net savings is about \$62,000 per year, the cumulative net savings over 25 years is \$1.5 million, the Net Present Value of the Cumulative Annual Net Savings is \$0.881 million, and the Rate of Return (IRR) is 16%. While the first year results in a modest cost to the City, the savings start in year 2 and build over time so that in the 25th year the project savings are estimated to be about \$165,000.

Table 12: Summary of REM 9-4 - Flotovoltaic PPA Solar Project

Analysis Period (Yrs)	Average Electricity Savings (kWh/Yr)	First Year Savings (\$/Yr)	GHG Emission Reduction (MT/Yr)	Capital Cost (\$)	Average Annual Net Savings (\$/Yr)	Cumulative Net Savings (\$)	NPV of Cumulative Net Savings (\$)	IRR (%)
25 Yrs	1,357,800	\$8,900	146	\$200,000	\$61,800	\$1,546,000	\$881,000	16%
20 Yrs	1,357,800	\$8,900	146	\$200,000	\$42,900	\$857,100	\$540,900	15%

The savings from a PPA contract depends on numerous factors, and one of the key variables is the PPA price (\$/kWh) over 25 years. The table below shows that the savings decline as the PPA price goes up; the breakeven price is \$0.143/kWh (meaning the project is no longer cost-effective).

Table 13: Results for Different PPA Prices for REM 9-4 - Flotovoltaic Solar Project

PPA Price (\$/kWh)	Average Annual Net Savings (\$/Yr)	Cumulative Net Savings (\$)	NPV of Cumulative Net Savings (\$)	IRR (%)
\$0.111	\$61,800	\$1,546,000	\$881,000	16%
\$0.12	\$47,200	\$1,180,000	\$632,900	12%
\$0.13	\$30,900	\$773,400	\$357,100	8%
\$0.14	\$14,700	\$366,800	\$81,400	5%
\$0.15	(\$1,600)	(\$39,800)	(\$194,400)	1%

9.14.4 REM 9-5: Pond Surface Lease

Ciel & Terre offered to lease a pond surface (3 acres) from the City to install a 1 MW solar PV flotovoltaic project. The City would receive revenue from the lease at \$2,000 per acre of pond surface, or about \$6,000 per year. The lease rate would not escalate over the 25 year lease term. The City would not use or purchase any of the power generated at the site. Instead it would be sold to Sonoma Clean Power (SCP) as a locally sourced solar PV generation project. Ciel & Terre offered an additional incentive of \$0.01 per kWh sold to SCP for the first five years. They estimate this incentive to generate nearly \$16,000 per year for an estimated five year total of \$79,600. Beyond the lease payments the City would benefit from reduced water evaporation and less bank

Final Technical Memorandum #9
 Santa Rosa EOP – Task 2.4 Solar PV Investigation
 Page 21

erosion on the reservoir. On the downside, the flotovoltaic projects could have a modest impact on City operations of the pond.

The results of the cost-effectiveness analysis for this option is that the average annual net savings is \$7,500 per year, the cumulative net savings over 25 years is nearly \$293,000, the Net Present Value of the Cumulative Annual Net Savings is \$187,000, and the Rate of Return (IRR) is 107%. We assumed it would require \$20,000 in upfront administration and legal cost to negotiate the contract and do some initial setup, so the first year savings would only be about \$2,000.

Table 14: Summary of REM 9-5 - Pond Surface Lease

Analysis Period (Yrs)	Average Electricity Savings (kWh/Yr)	First Year Savings (\$/Yr)	GHG Emission Reduction (MT/Yr)	Capital Cost (\$)	Average Annual Net Savings (\$/Yr)	Cumulative Net Savings (\$)	NPV of Cumulative Net Savings (\$)	IRR (\$)
25 Yrs	1,576,100	\$1,900	0	\$20,000	\$7,500	\$292,800	\$187,300	107%
20 Yrs	1,576,100	\$1,900	0	\$20,000	\$8,900	\$176,900	\$141,000	107%

If this arrangement worked out for the City it could be expanded to other ponds with larger solar PV flotovoltaic projects. Ciel & Terre suggested a 10 MW project leasing 25 acres generating \$50,000 per years, and \$1.25 million over 25 years.

9.15 Comparison of Costs and Savings

The table below compares the five options presented above. The most cost-effective option is the Flotovoltaics solar project with a PPA, followed by a ground mounted system with a PPA.

Table 15: Comparison of Cost and Savings of Each Option¹

Option and Type of Solar Project	Capital Cost (\$)	Average Annual Net Savings (\$/Yr)	Cumulative Net Savings (\$)	NPV of Cumulative Net Savings (\$)	IRR (%)
REM 9-1: Ground Mounted - NEM	\$3,810,000	(\$19,500)	(\$487,900)	(\$543,300)	3%
REM 9-2: Ground Mounted - RES-BCT	\$3,585,000	(\$179,300)	(\$4,483,100)	(\$3,053,100)	-6%
REM 9-3: Ground Mounted - PPA	\$1,250,000	\$52,300	\$1,307,200	\$651,900	7%
REM 9-4: Flotovoltaic - PPA	\$200,000	\$61,800	\$1,546,000	\$881,000	16%
REM 9-5: Pond Lease	\$20,000	\$7,500	\$292,800	\$187,300	107%

¹ The specificity of the cost and savings estimates are the results of Excel calculations, but the cost estimates provided in this analysis are based on the Association for the Advancement of Cost Engineering International (AACEI) standards for cost estimating accuracy of +50% and -30%.

The most cost-effective option is the Flotovoltaic option using a PPA. With the expiration of the CSI incentive, and the extension of the Federal Investment Tax Credit, the PPA option provides significantly more value to the City than an own and operate system. The lower CTS mitigation and CEQA study cost of the Flotovoltaic-PPA option lower its overall cost and thereby create more benefit to the City. The own and operate design/build option also has an upfront capital cost that is \$3.4 million more than the flotovoltaic system with a PPA. Signing a PPA for a solar project would also free up the \$3.4 million in capital that could be used on other cost-effective energy projects. A close second in cost-effectiveness is the Ground Mounted options with a PPA.

9.16 Recommendation

The preferred site from the above site evaluation analysis is Pond B, which is adjacent to and west of the LTP. The proximity to the LTP allows Pond B site to be “behind the meter,” meaning it can take advantage of the higher average LTP rate compared to the lower NEM or RES-BCT rates. Pond B out-scored the land-based sites predominantly because of its lack of potential impact on CTS critical habitat and the fact that it may not be in the viewshed of nearby homes.

A PPA at Pond B provides the City with the best value and highest savings. However, the flotovoltaic solar system should not be considered as proven a technology as traditional ground mounted solar systems. While Ciel & Terre has numerous installations in Europe and Japan, their installations are very limited in the US and there are no large installations in California. Sonoma County Water Agency has been working on this concept for several years with another flotovoltaic developer and still has not installed a system. While the solar panels are tested and proven, floating systems should still be considered a relatively new deployment system. There is more risk associated with choosing this type of system over a more traditional ground mounted system. This added risk needs to be weighed against the significant capital costs added to ground mounted projects because of CTS issues on the City-owned sites. A flotovoltaic project at Pond B using a PPA could also provide the City with annual savings that build over time (e.g., starting out with a small \$8,900 cost and building to an estimated \$158,000 by year 25).

Of the land-based sites 4220 Walker and Karcher had the same score, and they had an advantage over 4030 Walker because it is being considered for future projects that may or may not be compatible with a solar project. 4220 Walker is adjacent to the LTP and has the potential to be interconnected with the LTP thus allowing it to be “behind-the-meter” to take advantage of the higher average LTP rate compared to the lower NEM or RES-BCT rates. Moreover, if the CTS issues on this site can be resolved without significant costs, then this site could be developed and it could be more cost-effective than the Flotovoltaic-PPA at Pond B option.

Finally, the Pond Lease options is cost-effective, and while it has a much lower NPV of cumulative net savings, it has by far the highest rate of return on investment at 107%, compared to 16% for the Flotovoltaic-PPA options and 7% for the Ground Mounted-PPA option.

We therefore recommend the following:

1. REM 9-5: Further investigate the Pond Lease option with Ciel & Terre for a 1 MW flotovoltaic solar PV system on Delta Pond. Because this option is low risk, has very little upfront capital cost, and can be an easy entree into larger scale solar PV projects, this

option deserves serious consideration by the City. Leasing part of Delta Ponds would still allow a future photovoltaic projects because of its size at over 52 acres.

2. REM 9-4: Further investigate a PPA for a 1 MW photovoltaic on Pond B, and determine if it can be cost-effectively interconnected with the LTP allowing it to be “behind-the-meter” to take advantage of the higher average LTP rate compared to the lower NEM or RES-BCT rates.
3. REM 9-3: Further investigate the development of a 1 MW ground mounted solar PV system with a PPA at 4220 Walker. Determine whether the site can be cost-effectively interconnected with the LTP allowing it to be “behind-the-meter” to take advantage of the higher average LTP rate compared to the lower NEM or RES-BCT rates. Finally, it should be determined if the CTS issues on this site can be resolved without significantly more costs than the \$900,000 estimated in this analysis.

9.17 Next Steps

Should the City elect to proceed with these recommendations the next steps that should be taken are:

1. Discuss potential 1 MW solar PV projects with PG&E and SCP, and determine their concerns and the utility requirements the City will need to take to develop a solar PV project.
2. Conduct a detailed cost/benefit analysis and rate study to determine the NEM and RES-BCT rates and credits, that should include:
 - a. NEM 2.0 rate reductions.
 - b. The applicable TOU rate structure.
 - c. The inability of a solar project to fully offset demand charges.
 - d. Modelling of specific solar project hourly output and calculation of the RES-BCT credit (by applying the corresponding TOU period generation component of the energy charge for the applicable rate tariff).
 - e. Compare the benefits associated with different rate structures (e.g., E-20 vs A-6), and determine if the preferred solar sites can use the rate with the higher credit benefit (i.e., the A-6 rate).
 - f. Conduct a sensitivity analysis on potential changes to the TOU structure.
3. Compare the cost-effectiveness of a single-axis tracking solar equipment to a fixed tilt solar PV system. Depending on the system and the cost, tracking single-axis systems can be as much as one cent per kWh lower in cost when compared to a fixed tilt system.
4. Begin discussions with Ciel & Terre about a Pond Lease and 1 MW Photovoltaic solar PV project with a PPA.
5. Continue discussions with SCWA about their efforts to develop photovoltaic projects and glean their lessons learned from going through the PPA solicitation and development processes.

Final Technical Memorandum #9
Santa Rosa EOP – Task 2.4 Solar PV Investigation
Page 24

6. More clearly determine the CTS issues at the 4220 Walker and Karcher sites, and refine the cost estimates for CTS mitigation and CEQA studies.
7. Investigate the feasibility and cost-effectiveness of creating an interconnection between 4220 Walker and Karcher sites and the LTP to enable these sites to be “behind-the-meter” allowing them to use the higher LTP average cost.
8. Conduct a legal review of potential PPA and Pond Lease contract terms.
9. Investigate standardizing monitoring software for existing city solar PV projects using the eGauge system. Standardization and automation will be more efficient and cost-effective.
10. Continue contracting for cleaning and maintenance of existing city solar PV projects.
11. Investigate the use and cost-effectiveness of batteries to compliment solar PV projects to reduce peak demand costs and energy use.
12. Perform a more detailed analysis to assess if SCP’s ProFIT program would create more economic benefit to the City than the NetGreen or Net Metering programs.
13. Investigate ability to use California Code 4217 to do a sole-source procurement should the City wish to pursue an own and operate structure.

Technical Memorandum
Santa Rosa EOP – Task 2.4 Solar PV Investigation

APPENDICES

- A - Energy Production from Different Types of Solar Systems
- B - Solar PV Installation Options
- C - Local Solar PV Companies and Considerations Making A Selection
- D - Purchase Structures and Roles
- E - Potential Solar PV Incentive Programs
- F - Evaluation of Existing City Solar PV Systems
- G - Maps of the Top 5 Individual Potential Solar PV Sites

Technical Memorandum
Santa Rosa EOP – Task 2.4 Solar PV Investigation

APPENDIX A

Energy Production from Different Types of Solar Systems¹

3 to 5 acres are needed for a 1 MW fixed tilt solar system. Recent information from SolarCity estimates that 1 MW would use about 5 acres, and we used this conservative assumption in this analysis. Ciel & Terre estimates that it needs 3 acres of reservoir or pond surface for a 1 MW flotovoltaic solar project.

To determine kWh production for the City, the electricity production per kW was calculated using the PVWatts tool developed by the researchers at the National Renewable Energy Laboratory (NREL): <http://pvwatts.nrel.gov/>.

The PVWatts calculator works by creating performance simulations that provide estimated monthly and annual energy production in kW and energy value. It uses meteorological year weather data for the selected location and determines the solar radiation. Solar radiation is then converted and annual alternative current (AC) energy production is calculated (in kWh per year per installed kW). Based on PVWatts calculations for the Santa Rosa area, the annual energy production per kW for fixed-tilt and tracking systems is shown in Table A-1. While single-axis and dual-axis solar tracking systems generate more energy than fixed tilt systems, they are substantially more costly. As shown in Table A-1 single-axis tracking systems are about 23% more efficient than fixed tilt systems.

Table A-1: PVWatts Estimated Production by Type of System

Tilt	First-Year Energy Production (kWh produced per kW installed) ¹
Fixed tilt at latitude	1,441
0 degree tilt single-axis tracking	1,766
0 degree tilt dual-axis tracking	1,946

¹ Includes energy production during first year after installation.

PV systems emit no greenhouse gases (GHGs) during operation and avoid the impacts from GHGs that would otherwise be emitted by the fossil fuel-generated electricity they replace. In the case of the City, the electricity supplier is Sonoma Clean Power (SCP). The GHG emissions factor for SCP, as of 2016, is approximately 224 pounds of CO₂ per MWh of energy produced. As shown in Table A-2, a single 1 MW DC (name plate rating) array of a fixed tilt and single-axis tracking PV panels would avoid emitting approximately 146 and 179 metric tons of CO₂ per year, respectively.

¹ Solar PV has its roots in 19th Century France. Alexandre-Edmond Becquerel, a French physicist, discovered the photovoltaic effect in 1839 (177 years ago). This effect is simply the production of electricity from sunlight. Becquerel effectively created the first solar cell using selenium as a semiconductor. Modern solar PV cells were developed in the 1950s in the aerospace industry and have been used in utility-scale applications for nearly 30 years. [Source: derived from Solar Power Now, a solar PV advocacy website <http://solar-power-now.com/photovoltaics/>]

Technical Memorandum
Santa Rosa EOP – Task 2.4 Solar PV Investigation

Table A-2: Projected Annual Energy and GHG Reduction

Size	Type	Annual kWh Produced¹	Annual Metric Tons of CO₂ Reduced
1 MW DC	Fixed Tilt at Latitude	1,441,000	146
1 MW DC	Single-Axis Tracking	1,766,000	179

¹ First year's generation. System efficiency degrades at a rate of about 0.5% per year.

Technical Memorandum
Santa Rosa EOP – Task 2.4 Solar PV Investigation

APPENDIX B

Solar PV Installation Options

There are two solar PV installation options considered in this analysis: ground-mounted and floating (or flotovoltaic). Ground-mounted solar PV is the traditional approach to solar project development whereby the panels are deployed on structures at a fixed tilt angle. Fixed tilt installations are what the City has installed to date. The figure below shows the fixed tilt system installed at the LTP. The City is very familiar with this installation option.



Figure B-1: Fixed Tilt System Installed at Laguna Treatment Plant

Alternatively, solar PV panels can be deployed using a single or dual axis tracking system or a dual axis (see the figure below). Single-axis trackers tilt along the y-axis (enabling them to capture a bit more sun than traditional fixed systems), dual-axis trackers move along both the x- and y-axes. Solar tracking installations can increase the production capacities of projects. While fixed tilt systems only collect maximum power for a few hours in the middle of the day, trackers can maintain this capacity throughout the entire day. Because they follow the sun from dawn to dusk, dual-axis solar trackers can capture all of the day's solar potential, resulting in up to 45 percent more energy than fixed solar.² Single and dual axis systems add capital and maintenance cost to a solar PV project, but do increase energy production. The trend is to build more single-axis tracking systems as the reliability and cost of installation has improved, often making these systems cost-

² <https://www.allearthrenewables.com/blog/pv-tracker-vs-pv-fixed-mount-system>

Technical Memorandum
Santa Rosa EOP – Task 2.4 Solar PV Investigation

effective to install. Should the City pursue a ground-mounted system it should get bids to compare the prices for both fixed-tilt and single-axis systems.



Figure B-2: Single-Axis and Dual-Axis Tracking Systems

Floating solar systems have the potential to be cost-effective while utilizing pond surfaces for the installation in lieu of relatively valuable surface land. Numerous environmental impacts studies have been done on flotovoltic systems and they conclude there are no deleterious impacts from the system. In fact, the studies show that there are several co-benefits of these systems: they reduce water evaporation, they reduce algae growth resulting in lower chemical treatment costs, and they reduce pond wave action which reduces shores erosion. However, they are new, and as of yet there are no large scale systems operating in the US.

One company, Ciel & Terre has developed a new system that is made of UV resistant and waterproof high density polyethylene (HDPE) which is drinking water safe. They have installed their Hydrelion modular system at 16 different locations, mostly in Japan and Europe. The flexible modular design is very adaptable to fit any pond's dimensions. It takes about 3 acres for each 1 MW of solar panels. Each pontoon is connected with pins that create a hinge allowing the overall structure to be flexible and withstand winds over 100 miles per hour. The overall structure uses shore anchors to keep the solar arrays in position to optimize power output. The system uses waterproof aluminum connections and conduits, and is national electric code compliant.



Figure B-3: 1.2 MW Flotovoltic System Installed in Okegawa, Japan

Technical Memorandum
Santa Rosa EOP – Task 2.4 Solar PV Investigation

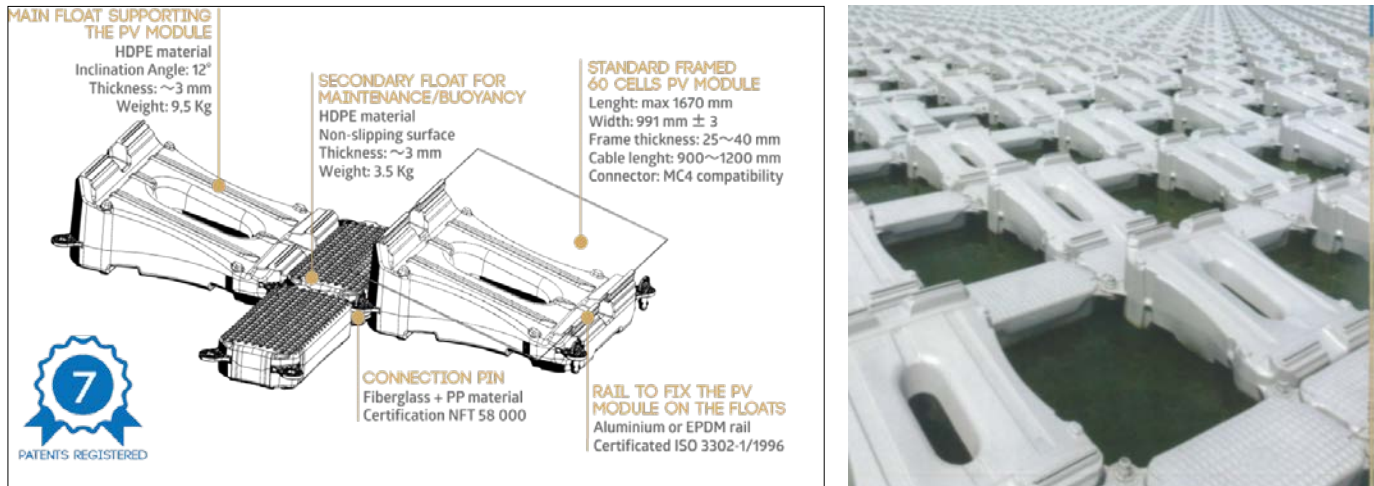

Figure B-4: Ciel & Terre's Hydrelío Modular System

In 2015 the Sonoma County Water Agency (SCWA) signed a lease agreement with Pristine Sun of San Francisco for 12.5 MW of flotovoltaics on SCWA storage ponds. However, their system design is not yet complete, and as of December 2016 development has yet to proceed. Pristine Sun's system and design is apparently different than the Ciel & Terre system described above. The plan is to have the energy generated by this project to be sold to Sonoma Clean Power (SCP) via a PPA to make up a large portion of their renewable portfolio for customers in Sonoma County.

The modular flotovoltaic systems are designed so that they can float up and down as the pond water level changes. Some ponds are lined while others have dirt bottoms, and there is some concern from operators that the floats could act as point loads and damage the pond liners, or that the floats would get mired in the dirt or mud bottom and not be able break free when refilling. SCWA does not anticipate that there will be much effect from the "unevenness" of the pond bottom as all have been graded evenly. That is not to say that there may not be operational issues.

Technical Memorandum
Santa Rosa EOP – Task 2.4 Solar PV Investigation

APPENDIX C

Local Solar PV Companies and Considerations Making a Selection

There are over 80 solar PV companies in the Sonoma County area. A vetted list of qualified companies from Solar Sonoma County include:

- Advanced Alternative Energy Solutions, d.b.a. Aloha Solar
- Michael & Sun Solar
- North Coast Solar
- Northern Pacific Power Systems
- Pathways Solar Energy Brokers
- Pure Power Solutions
- REPOWER by Solar Universe Santa Rosa
- Simply Solar
- Sun Solar Electric Inc.
- Synergy Solar & Electrical System Inc.
- West Coast Solar

Additional solar companies would include:

- Ciel & Terre
- Cupertino Electric
- Gehrlicher Solar
- SolarCity
- SunPower

In selecting a solar PV company to install a solar facility, there are several items to consider and possibly to call out in a solicitation:

- Licensing: Does contractor have a Class A, B, or C10 license?
- Wages: Does the contract meet the City's prevailing wages requirements?
- Track Record: Does the contractor have a minimum of five years' experience completing solar installations in California, including at least two 250 kW systems of the same installation type as the City is proposing?
- California Solar Initiative (CSI) Guidebook: Are they familiar with the requirements in the CSI Guidebook, and do their systems incorporate these elements?
- Equipment: What manufacturer/brand of panels and inverters do they use, and where are they sourced?

Technical Memorandum
Santa Rosa EOP – Task 2.4 Solar PV Investigation

- Warranty: Do they have a balance sheet to back their warranties?
- Maintenance: Who performs the maintenance?
- Insurance: Do they have the appropriate insurance (general, liability, workers' compensation) from design through construction?
- Safety record: Does the contractor have an excellent job safety record?
- Decommissioning: Do they provide decommissioning and site restoration at the end of the project design life?

Some of these solar PV companies also may offer PPAs. In evaluating a PPA company, there are two important considerations: track record and PPA terms. Terms to be considered include:

- Price per kWh that the third party charges the City for the electricity generated.
- Fixed price or annual escalator on the price.
- Duration (usually 20 to 30 years) of the contract.
- Potential extension or buyout terms.

Technical Memorandum
Santa Rosa EOP – Task 2.4 Solar PV Investigation

APPENDIX D

Purchase Structures and Roles

The City could pursue a solar PV project through three different purchase structures options:

- **Own and Operate (O&O)**: The City would purchase a solar PV system using its capital, install the system on its property, and use the City staff to operate the system. Capital would come from City reserves, or through a financing mechanism such as a bond.
- **Power Purchase Agreement (PPA)**: A third party would finance, own, and operate the solar PV system, and the City would purchase the power generated from the third party. This could be an advantage for the City because of no upfront capital costs and the availability of tax credits to a third party (which could in part be rolled into the pricing for the City)³.
- **Lease**: The City would lease its land or a pond to a solar power developer and benefit from lease payments. The City would not use or purchase any of the power generated at the site.

These purchase structures are discussed in more detail in the sections below.

Previously the City used the own and operate structure with a design/build contract. Until recently the City performed all the O&M for its existing solar facilities; it recently contracted out for selective cleaning and maintenance for several systems.

Own and Operate (O&O) Structure

Under an own and operate structure, the City would use its capital to purchase the system and then operate the system using City staff. The roles and responsibilities for an own and operate project are summarized in Table D-1.

Table D-1: Roles and Responsibilities for an Own and Operate Structure

Roles	Responsibility
Solar PV Company	<ul style="list-style-type: none"> • Designs and builds the solar PV system for a fee
City	<ul style="list-style-type: none"> • Finances/owns/operates solar system • Signs a Net Metering contract and interconnection agreement with SCP • Maintains ownership of the Renewable Energy Credits (RECs)
Utility	<ul style="list-style-type: none"> • Signs a Net Metering contract and interconnection agreement with the City • Provides inspection and Permission To Operate (PTO) • Administers and does the billing for the Net Metering program

³ Tax-exempt entities such as the City are not eligible for tax credits under an own and operate system. Under a PPA agreement, tax savings to a third party could, however be partially rolled into the pricing under the agreement.

Technical Memorandum Santa Rosa EOP – Task 2.4 Solar PV Investigation

The City could use traditional funding mechanisms to purchase solar equipment. For example, cash from reserves or municipal bonds would allow for inexpensive debt financing at a more favorable rate than through a lease agreement from a developer. (Note: municipal bonds issued for certain purposes may not be tax exempt and would not offer as favorable an interest rate, but O&O solar PV projects where the electricity is used at a City facility should be tax exempt.) Different types of bonds are secured by various types of repayment sources:

- General Obligation Bonds: Promise to repay based on the full faith and credit of the issuer; these bonds are typically considered the most secure type of municipal bond, and therefore carry the lowest interest rate.
- Revenue Bonds: Promise repayment from a specified stream of future income, such as income generated by a utility from payments by customers.
- Assessment Bonds: Promise repayment based on property tax assessments of properties located within the issuer's boundaries.
- Clean Renewable Energy Bonds (CREBs): administered through the federal government, this is a special type of tax credit bond providing rural electric cooperatives, municipal electric utilities, and government entities the equivalent of an interest-free loan for financing qualified energy projects (including solar PV projects). The City could explore this program to determine if it offers favorable terms and rates.

Purchase Power Agreement (PPA) Structure

Under a PPA structure, a third party would finance, own, and operate the solar PV facility and would require the City to purchase the electric output of the facility. This structure has two advantages to the City: 1) the City has no up-front capital requirement, and 2) the City would realize a lower PPA price that lowers its overall energy bill. It is important to highlight that a PPA agreement is complex and long-term. The City would need to confirm projected energy generation rates and cost savings, and perform legal due-diligence to ensure that it enters an agreement that is in the best interest of the City. Also, the PV system would be on the City's property for a long time, and it is important to thoroughly vet the solar PV company offering the PPA. The typical terms in a PPA agreement are summarized in Table D-2.

Technical Memorandum
Santa Rosa EOP – Task 2.4 Solar PV Investigation

Table D-2: Typical PPA Contract Terms

Contract Term	PPA
Contract Life	20-25 years
Payment	Pay for power generated
Maintenance and Monitoring	Included
Tax benefits	Goes to solar company as owner of the equipment
Renewable Energy Credit	Can be owned by either the City or the solar company
Net Metering	Benefit goes to the City
End of contract	Option to remove, buy, or continue PPA
Early buy out	Usually possible

The roles and responsibilities in a PPA structure are summarized in Table D-3.

Table D-3: Roles and Responsibilities in a PPA Structure

Roles	Responsibility
Solar PV Company	<ul style="list-style-type: none"> • Finances/designs/builds/owns/operates/ and maintains solar system • Signs site lease with the City • Signs PPA with the City
City	<ul style="list-style-type: none"> • Signs site lease agreement with Developer • Signs PPA with Developer • Provides design input and review • Purchases solar electricity produced at set \$/kWh • Negotiate for the City ownership of RECs
Utility	<ul style="list-style-type: none"> • Administers the Net Metering program and sends the City its monthly energy bills

Lease

Ciel & Terre offered to lease a pond surface (3 acres) from the City to install a 1 MW solar PV photovoltaic project. The City would receive revenue from the lease at \$2,000 per acre of pond surface, or about \$6,000 per year. The lease rate would not escalate over the 25-year lease term. The City would not use or purchase any of the power generated at the site. Instead it would be sold to Sonoma Clean Power (SCP) as a locally sourced solar PV generation project. Ciel & Terre offered an additional incentive of \$0.01/kWh sold to SCP for the first five years. They estimate this incentive to generate nearly \$16,000 per year for an estimated five year total of \$79,600. If this arrangement worked out for the City it could be expanded to other ponds with larger solar PV

Technical Memorandum
Santa Rosa EOP – Task 2.4 Solar PV Investigation

flotovoltaic projects. Ciel & Terre suggested a 10 MW project leasing 25 acres generating \$50,000 per years, and \$1.25 million over 25 years. Beyond the lease payments the City would benefit from reduced water evaporation and less bank erosion on the reservoir. On the downside, the flotovoltaic projects could have an impact on City operations of the pond.

A summary and comparison of ownership structures is presented in Table D-4.

Table D-4: Ownership Structure Summary and Considerations

Ownership Structure	Description	Benefit	Drawback
Own and Operate (O&O)	The City would purchase a solar PV system using its capital, install the system on its property, and use City staff, or a third party contractor, to maintain the system	<ul style="list-style-type: none"> • Higher financial reward 	<ul style="list-style-type: none"> • Risk of system under-performance is the responsibility of the City • The City is responsible for all costs of ownership
Power Purchase Agreement (PPA)	A third party would finance, construct, own and operate the solar PV system, and the City would purchase the power generated from the third party	<ul style="list-style-type: none"> • Risk of system under-performance is the responsibility of the third party • No upfront capital cost for the City • No operations and maintenance for the City • Potential for PPA price that lowers the City's energy costs 	<ul style="list-style-type: none"> • Lower reward because third-party applies a risk premium to compensate for system under performance risk • PPA firm stability • Risk of signing a complex contract
Lease	City would lease land or a pond to a solar company to develop a solar project for sale to the utility	<ul style="list-style-type: none"> • Lease payments • No operational concerns or risks • Reduce water evaporation and bank erosion 	<ul style="list-style-type: none"> • No renewable energy added to the City's energy portfolio, nor any reduction in GHGs

Technical Memorandum
Santa Rosa EOP – Task 2.4 Solar PV Investigation

APPENDIX E

Potential Solar PV Incentive Programs

Many local, state, and federal rebates and incentives are available for solar energy projects. They vary based on size of system and ownership (public entity or private). The following is a summary of incentives for which the City may be eligible, including two solar-specific incentives.

1. California's Net Energy Metering

Net Energy Metering (NEM) program applies to solar projects that are intended for the onsite use of the generated energy (sometimes referred to as being “behind the customer meter”). NEM is a utility rate tariff that allows customers to generate their own electricity, export any excess electricity to the grid, and get credited for the excess energy produced. Effectively, the meter can run backwards, causing a credit with the utility. The City does not have to own the eligible renewable resource; however, the output must be dedicated to offset the electricity used at that onsite meter. Excess generation is carried from one month to the next in the form of a bill credit. After 12 months, there is a true-up that sets the generation back to zero. If the facility has a “net-deficit” then the facility will owe money to the utility. If the facility has a “net-credit” then the excess generation can be sold to the local utility. As a PG&E customer, Net Excess Generation (NEG) electricity beyond that month's actual usage is carried over as a credit within a 12-month cycle, but at a substantially lower value. <http://www.pge.com/en/b2b/interconnections/index.page>.

The NEM tariff is going through a transition. The NEM1 tariff had a MW cap (5% of peak utility demand) on project availability, after which the tariff terminated at the end of 2016. However, AB 327 required the California Public Utilities Commission (CPUC) to create a successor program, and on January 28, 2016 the CPUC issued a decision clarifying the new rules (NEM 2.0). NEM 2.0, the current NEM tariff, sets the tariff for the next 4 years until a comprehensive review of the tariff in 2019. NEM 2.0 continues the previous tariff with several changes:

- New NEM projects now have to pay a modest one-time cost-based interconnection fee for administration costs, engineering, meter installation, and commissioning. For projects less than 1 MW the fee will likely be in the \$75-\$150 range.
- NEM projects now have to pay non-bypassable charges on any energy that is exported onto the utility grid via net metering, and include: public purposes charge, nuclear decommissioning charge, competitive transition charge, and the Department of Water Resources bond charge. The total of these non-bypassable charges will reduce previous NEM benefit by about \$0.023 per kWh on the E-20 rate tariff. If the solar project is not on a NEM contract these charges may not be incurred by the LTP due to the plant's high energy use and therefore it is unlikely that the meter will “spin backwards.” A detailed analysis of solar output compared to the facility's energy use is required to accurately assess if the non-bypassable charges would be deducted.
- The TOU rates and time periods, for the meter to which the NEM projects is connected, apply to the credit calculation.
- The 1 MW size limitation has been removed; however, projects that are greater than 1 MW are required to pay the cost of an interconnection study.
- Meter Aggregation and Virtual Net Metering (see below) will continue.

Technical Memorandum
Santa Rosa EOP – Task 2.4 Solar PV Investigation

- NEM is applied for 20 years.
- There is a 10-year warranty requirement for all equipment.
- Annual, as opposed to monthly, true-ups will continue.

Of note: the investor owned electric utilities are taking legal action to try and overturn the CPUC NEM 2.0 decision.

NetGreen

SCP's NetGreen program is essentially the same as PG&E's NEM program for solar PV projects smaller than 1 MW. There are a few extra benefits that SCP offers that PG&E does not (e.g., excess electricity produced is credited at the retail value plus \$0.01/kWh, credits are banked to help cover any SCP generation charges throughout the year, and an annual balance cash-out occurs automatically if any unused credits occur up to \$5,000.)

For this analysis, we estimated the offset electric rate by using the average rate for the LTP (\$0.1155/kWh calculated from data provided by the City for the period October 2015 – September 2016 under the Clean Start and E-20 rate schedules), applying a reduction of \$0.023/kWh because of the NEM 2.0 rules changes, and applying another reduction of 20% to account for solar project's inability to fully offset demand charges. We estimate that this makes the NEM rate about 64% of the average LTP rate or \$0.074/kWh.

Recommendation: The cost-effectiveness analysis in this Tech Memo is based on the approximate reduction from NEM 2.0, and reducing the effective average rate for the LTP by \$0.023/kWh. Kennedy/Jenks strongly recommends that the City do a more detailed NEM rate and benefit analysis to assess the impacts of NEM 2.0, and the application of the TOU rates and periods on a solar project's hourly output.

2. RES-BCT

AB 2466 (codified as Section 2830 of the Public Utilities Code), was signed into law in September 2008 and allows local governments and special districts to install renewable generation of up to 5 MW at one location (the "generating account") within its geographic boundary, and to generate credits that can be used to offset the generation energy charges at one or more (up to 50) other "benefiting accounts" within the same geographic boundary. This billing arrangement is called Renewable Energy Self-Generation Bill Credit Transfer (RES-BCT). Unlike NEM, RES-BCT credits the City with ONLY the generation energy charges (kWh) portion of their utility rate schedule/tariff, and not the generation demand, distribution, transmission or other charges from the rate schedule/tariff (the City will still pay those charges and fees). Therefore, the incentive rate is lower than the NEM program. We estimate, based on reviewing previous solar project pro formas, that this makes the RES-BCT rate about 50% of the average LTP rate or \$0.0577/kWh

The RES-BCT FAQ can be seen at:

<http://www.pge.com/en/b2b/energytransmissionstorage/newgenerator/ab2466/index.page>

The credit is calculated by multiplying the generation energy (kWh) portion of the "generating account's" bill (\$/kWh) by the kWh produced by the system during applicable TOU periods. To maximize the financial benefit of NEM, the City should select a generating account meter associated with the solar PV project that has the highest applicable TOU rates to take advantage of higher peak TOU prices. The rate schedule for the benefiting account should remain on a lower

Technical Memorandum
Santa Rosa EOP – Task 2.4 Solar PV Investigation

peak TOU cost schedule to maximize the difference between the peak TOU generation credit and the peak TOU demand offset by the solar project.

This program could allow the City to pursue a single larger solar project at a City owned property other than the four sites studied in this analysis.

Recommendation: Should the City wish to use RES-BCT, it should conduct a detailed rate and benefit analysis using the RES-BCT rules and rate structures, and applying the hourly output of the solar projects, to assess the net value of a solar project for the City.

3. Feed in Tariff

PG&E operates a Feed in Tariff (FiT) that provides an incentive for projects that are 3 MW or less under the Renewable Market Adjusting Tariff (Re-MAT). Through the Re-MAT program, customers can choose: (1) full buy/sell version – PG&E buys all the generation from the renewable generator (net of station use), and sells the City all the electricity used at the site under its existing tariff, or (2) excess version – the City uses the generated electricity first to meet its own on-site electrical load, and PG&E purchases any electricity that is exported to the grid.

SB 1122 was signed by the Governor on September 27, 2012. It amends Section 399.20 of the Public Utilities Code and adds an additional 250 MW of capacity for investor owned utilities (IOUs) to offer eligible bioenergy feed-in tariff PPAs. PG&E has been allocated:

- 30.5 MW: Biogas from wastewater treatment, municipal organic waste diversion, food processing, and codigestion
- 33.5 MW: Dairy and other agricultural bioenergy
- 47 MW: Bioenergy using byproducts of sustainable forest management

For further information, please visit PG&E's BioMAT FIT webpage:

<http://www.pge.com/en/b2b/energysupply/wholesaleelectricitysuppliersolicitation/BioMAT/index.page>

ProFIT

ProFIT is Sonoma Clean Power's (SCPs) "Feed in Tariff" designed to promote the development of small-scale renewable energy projects less than 1 MW by directly purchasing the output of the project through a standard-offer contract with a flat/fixed price of \$95/megawatt-hour (MWh). Solar projects would qualify for a 10-year contract. Projects that meet the bonus eligibility criteria may qualify for up to \$130/MWh for the initial 5 or 10 years of the contract term.

Recommendation: The City should conduct a more detailed analysis to assess if the ProFIT program would create more economic benefit to the City than NetGreen (discussed below) or NEM.

4. Renewable Energy Credits

Renewable Energy Credits (RECs), also known as Green tags, Renewable Electricity Certificates, or Tradable Renewable Certificates, are tradable, non-tangible energy commodities that represent proof that 1 megawatt-hour (MWh) of electricity was generated from an eligible renewable energy resource. These certificates can be traded, and the owner of the REC can claim to have purchased renewable energy. RECs represent the environmental attributes of the electricity produced and are sold separately from commodity electricity. Revenue from RECs can be sold to subsidize the cost

Technical Memorandum
Santa Rosa EOP – Task 2.4 Solar PV Investigation

of developing a solar generating facility. For example, currently the retail price of RECs ranges between \$0.003/kWh to \$0.016/kWh. This translates into \$4,000 to \$20,000 per year for a 1 MW project. Some entities employ a short-term sale strategy whereby they sell RECs for the first 5 years of operations to help finance the solar facility and keep the RECs for years 6 through 20 or 30.

However, if the City were to sell a solar PV project's RECs it could no longer claim credit for generating renewable energy nor reducing GHGs. We assume the City will keep all RECs and therefore there are no revenue from RECs is included for any solar PV project.

More information about RECs can be found at:

(<http://apps3.eere.energy.gov/greenpower/markets/certificates.shtml?page=1>).

5. Meter Aggregation

Senate Bill 594 (Wolk, 2012, and approved by the CPUC in February 2014) added special condition 7 to the NEM tariff, which allows a customer with multiple meters to install a renewable generator to serve their aggregated load located on the same property as the generator, or on property contiguous or adjacent to that property, so long as all the properties are under the same customer's sole ownership or control. All the accounts must be under the same customer-of-record. This means daisy chaining of Aggregated Accounts is allowed if all eligibility requirements are satisfied.

For more information go to PG&E website at:

(<http://www.pge.com/includes/docs/pdfs/b2b/newgenerator/NEMA.pdf>)

6. Peak Demand Charges

Solar PV systems generally generate the highest amount of electricity during peak demand periods that are between the hours of noon and 6 pm. As a result, solar facilities can help shave peak energy demands and thus provide operational flexibility by allowing a facility to pump when utility prices are highest. This should result in a reduction in energy demand charges from the utility. Further, time-of-use rate for customers with renewable energy generation systems, such as PG&E's Option R (Renewable) rate structure, have no on-peak or mid-peak demand charges, and the Facilities-Related Demand (FRD) charges are reduced in exchange for higher on-peak and mid-peak energy charges. Note that the high peak energy charges are to encourage off-peak electricity usage, which may not always be feasible for the City. The City would need to run a few scenarios to determine if Option R would be financially beneficial, and how it could work as a customer of SCP. The PG&E Account Representative serving the City should have the tools to provide such an analysis.

In addition, PG&E may change their TOU rate structure in the future. It is suggested that the City look at a sensitivity or scenario analysis on a NEM project for various changes to the TOU rate structure. California Solar Energy Industries Association (CalSEIA) is working with the Public Utilities Commission to "grandfather" TOU periods for customers that have solar, and the City may want to consider supporting this effort. The City should also look into the cost-effectiveness of a new battery storage system to supplement the solar PV project, which may further reduce peak charges and could qualify for a Self-Generation Incentive Program (SGIP) incentive.

Technical Memorandum
Santa Rosa EOP – Task 2.4 Solar PV Investigation

7. Water District

SB 1755 (adding Sections 31149.7 and 71663.5 to the Water Code) authorizes municipal and county water districts to build, own and operate electric power plants to provide, generate and deliver electricity for their own purposes and sell the excess in the wholesale market (FIT, discussed above). Moreover, Sections 31149.7 and 71663.5 give water districts the authority to build their own transmission lines. The code does not specify the maximum size of the facility and the ability to participate in the RPS, NEM, or other rate-payer funded generation incentive programs.

8. Sole Source Contracts

California Government Code Section 4217 authorizes local governments to enter energy contracts on terms that are found to be “in the best interests” of the agency. This law allows a City to sole-source a solar PV own-and-operate contract so long as the anticipated cost for the energy project are less than the anticipated energy cost savings to be derived from those services. Should there be only one market-ready solar PV company offering photovoltaic solar projects, a City can consider using this law to justify a sole source contract. However, the City of Santa Rosa adopted Ordinance Number 4021, Chapter 3-60 in 2014, which established regulations for the award, use, and evaluation of design-build contracts. The City would need to review this ordinance in determining whether California Government Code Section 4217 is applicable for a potential project.

9. Tax Incentives

The Business Energy Investment Tax Credit (ITC) was extended in December 2015 and applies to solar PV projects. The ITC gives a credit for 30% of the capital cost of a solar PV project constructed through 2019 (then the rate drops to 26% for 2020, 22% for 2021, and then falls to 10% for 2022 and beyond). While tax-exempt entities such as the City are not eligible for tax credits, the City can indirectly benefit by a third-party taking the ITC and passing part of it along in a lower PPA price. The extension of the ITC can make a PPA contract a more cost-effective option over an own and operate structure with a design/build contract without the CSI incentive.

<http://programs.dsireusa.org/system/program/detail/658>

10. The California Solar Initiative (CSI)

A part of the Go Solar California campaign, the CSI offered rebates to customers in California's investor-owned utility territories. The incentives declined in 10 "steps" based on the volume of solar MW installed. PG&E and all the other private utilities in California have reached the maximum MW threshold, and therefore DO NOT OFFER the CSI incentive any longer. It does not appear that there is any replacement state incentive going to be offered in the near-term in California.

<http://www.gosolarcalifornia.ca.gov/csi/index.php>

Technical Memorandum
Santa Rosa EOP – Task 2.4 Solar PV Investigation

Appendix – F

Evaluation of Existing City Solar PV Systems

Since 2004, SRW has installed four owned and operated small solar PV projects on Subregional sites. Table F-1 shows the historic and current data for each of the four Subregional solar projects.

The design capacity and design output are the expected values told to the City by the installer upon installation. A typical solar panel is guaranteed to degrade by no more than 1% per year, meaning that the output of the system can decrease by 1% per year without voiding the warranty. It is common practice to estimate a degradation of 0.5% per year when projecting the output of an aged solar system. The “current adjusted capacity” and the “current adjusted design output” included in the table accounts for a 0.5% annual degradation.

Table F-1 also shows actual energy output over a twelve-month period (June 2015 to May 2016).

Table F-1: Existing Subregional Solar PV Systems and Performance

Project Name	Year Installed	Installer	Design Capacity (KW)	Design Output (kWh)	Current Adjusted Capacity (kW)	Current Adjusted Design Output (kWh)	Actual Output (kWh)	Percent of Current Adjusted Design Output (%)	Current Capacity Factor (%)	Value of Savings (\$/Yr)
LTP Ground	2004	OneSun	25	31,674	23.5	29,825	28,638	96%	13.9%	\$2,100
Alpha Farm	2006	OneSun	37.6	48,929	35.8	46,537	43,053	93%	13.7%	\$3,200
Brown Farm	2010	OneSun	77.8	120,258	75.5	116,695	124,642	107%	18.8%	\$9,200
LTP Solyndra	2011	Krutzfield	62.8	95,853	61.2	93,480	85,710	92%	16.0%	\$6,300
TOTAL			203.2	296,713	196.0	286,536	282,043	98.4%	16.4%	\$20,800

The “actual output” is compared to the “current adjusted design output” to determine if the project is meeting original output expectations. The City’s solar systems produced between 92% and 107% of the projected/expected energy output for the period. Following is a brief discussion of each system.

- The LTP ground mounted system is operating reasonably well, but below original expectations (96%). The system is 12 years old and there have been occasional panel failures that cause a portion of the system to not operate. The manufacturer, BP Solar, has been very good at replacing the panels under warranty.

Technical Memorandum
Santa Rosa EOP – Task 2.4 Solar PV Investigation

- Alpha Farm ground mounted system is operating reasonably well, but below original expectations (93%). The system has been operating for more than 10 years. The City is currently in the process of evaluating this system for operational issues.
- Brown Farm ground mounted system is operating particularly well, exceeding original expectation (107%). The system is 6 years old.
- The LTP Solyndra system is operating below original expectations (92%). This system is unique in its manufacture and design. The system uses a tube of solar encapsulated in glass, as opposed to the typical flat-plate collector. The system was provided to the City free-of-charge through a DOE grant. The system is 5 years old.

Preliminary conclusions about the Subregional solar PV systems are:

- Overall these projects are performing at a little below the originally expected output (at 95%).
- The total investment made by the City in these solar PV systems has been substantial and warrants reinvestment and a regular maintenance program (e.g., twice a year inspection and cleaning) to protect and optimize these investments. This is a common practice and the City currently has a two-year contract for cleaning and maintenance.
- While it would take a detailed rate study to determine actual annual savings, which would be beyond the scope of this analysis, we estimated savings using the estimated 2016 NEM rate for the LTP used in the cost-effectiveness analysis for potential projects. The savings from the projects is approximately \$20,800 per year, and can justify the added cost of the current cleaning and maintenance contract. Without an ongoing maintenance program or contract it is possible that the expected annual performance would decline and the annual degradation rate in output could accelerate.
- The City should standardize monitoring software using the eGauge system. Standardization and automation will be more efficient and cost-effective.
- At the workshop to develop the scope of work for this project, SRW staff noted that the Alpha Farm inverter was generating surplus heat. An inspection of the site determined that this was due to high August temperatures and there is not likely a cost-effective solution to cool the system down for the few hot summer months. Overall, the lower-than-expected performance at Alpha Farm can probably be attributed to this, and the lack of previous routine maintenance and cleaning of the system.

Technical Memorandum

Santa Rosa EOP - Task 2.4 Solar PV Investigation
Page A-20

Appendix-G

Maps of the Top 5 Individual Potential Solar PV Sites

1. Overview Map Locating All 5 sites
2. 4220 Walker
3. Karcher
4. 4030 Walker
5. Pond B
6. Delta Pond
7. Ciel & Terre Pond B Flotovoltaic Diagram

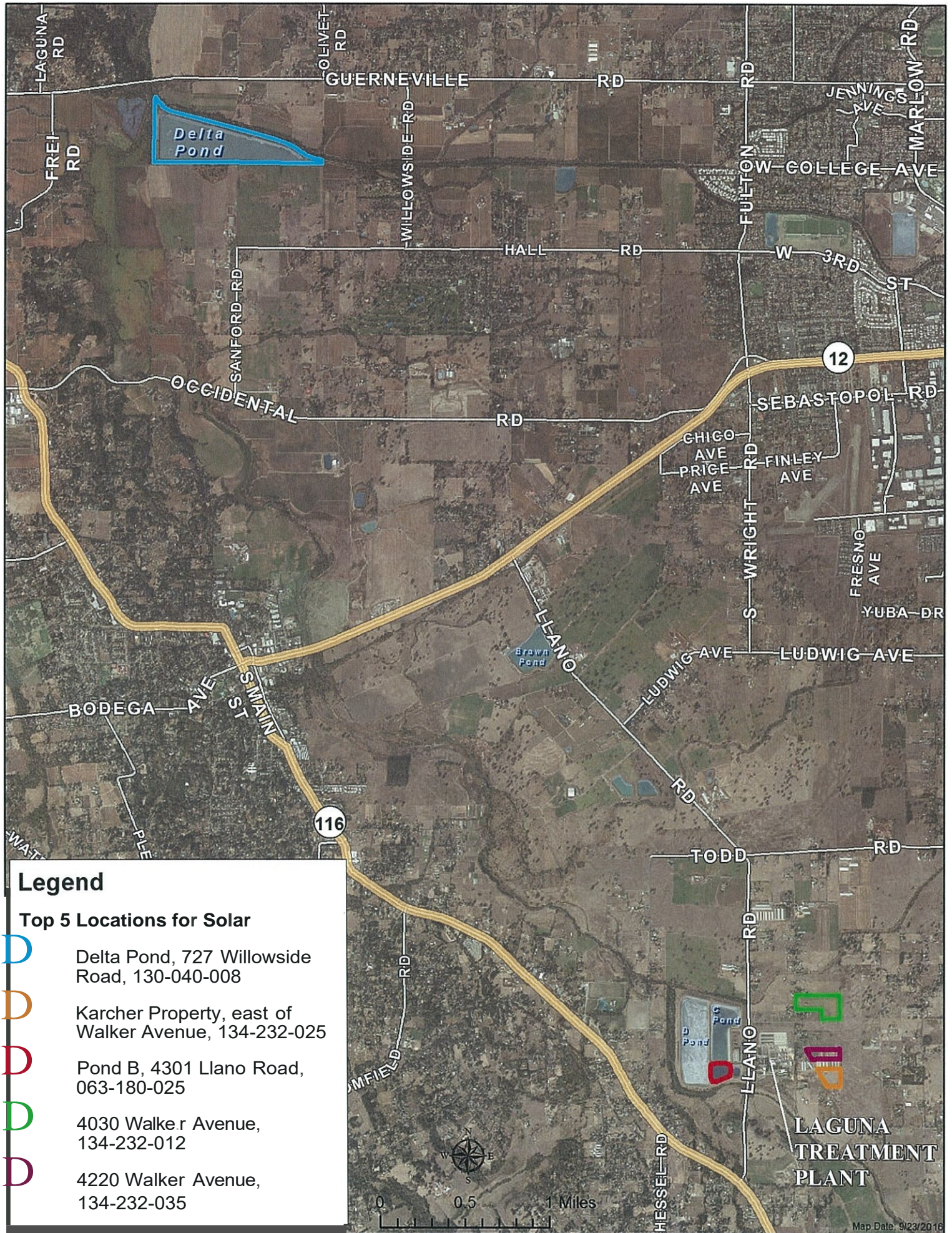

Legend

Top 5 Locations for Solar

- D Delta Pond, 727 Willowside Road, 130-040-008
- D Karcher Property, east of Walker Avenue, 134-232-025
- D Pond B, 4301 Llano Road, 063-180-025
- D 4030 Walker Avenue, 134-232-012
- D 4220 Walker Avenue, 134-232-035

**LAGUNA
TREATMENT
PLANT**

4220 Walker

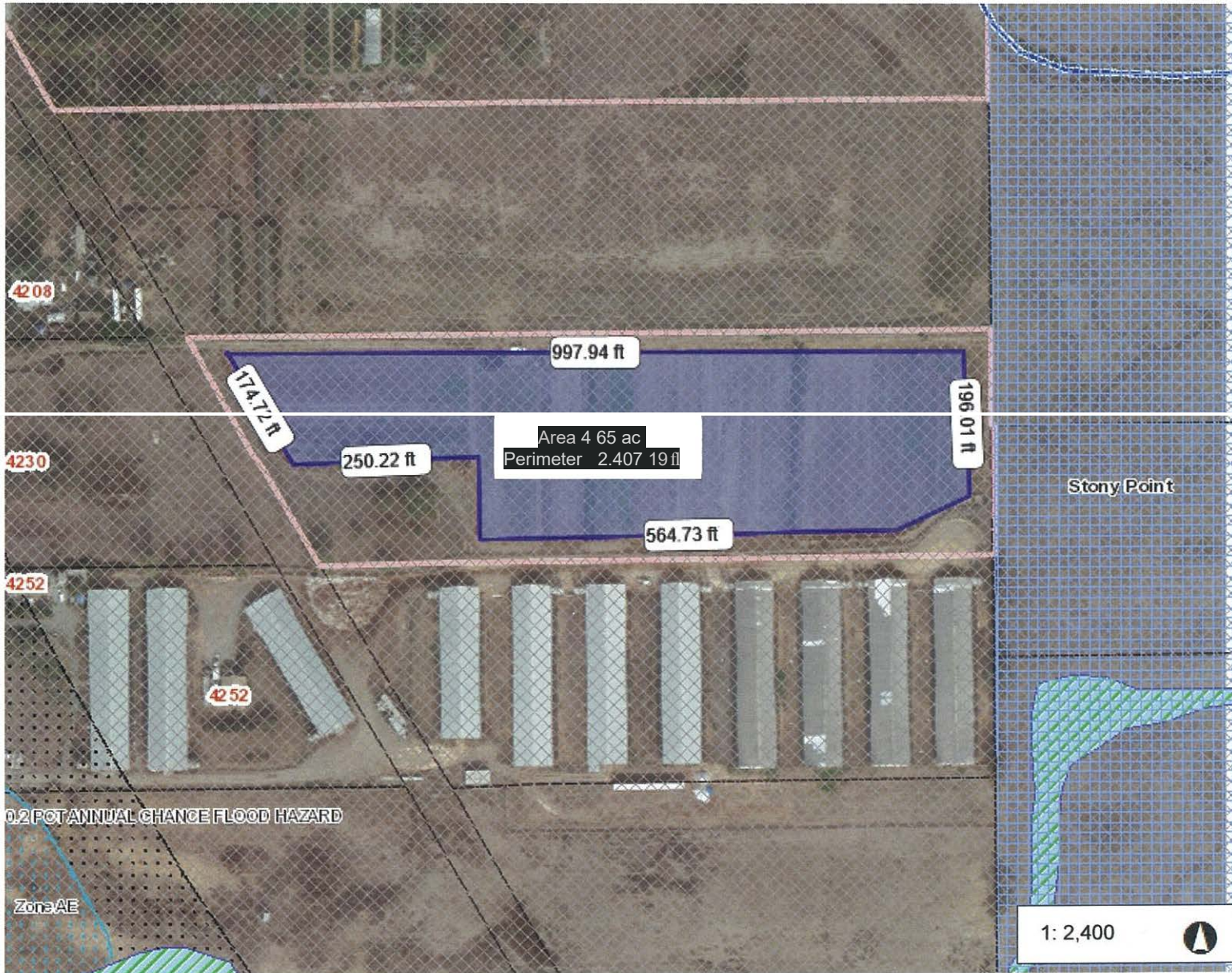

Legend

- 0 NPDES Boundary
- Proposed Conservation Areas
 - || Alt on Lane
 - Kelly Fann
 - Llano Crescent
 - Northwest Cotati
 - Southeast Cotati
 - Southwest Cotati
 - Southwest Santa Rosa
- C
 - || Stony Point
 - || Migh t
- Breeding Sites
- Wetlands
- [] Critical Habitat
- 0 Flood Insurance Rate Maps
- Flood Zones
 - 0 100 Year Flood
 - 0 500 Year Flood
- Creeks
 - Natural
 - Modified-Natural
 - Modified
- C City Boundary
- Park
 - Park
 - + Community Space
 - Historic
 - Open Space
 - Trail
- + Rail Road
- 0 Parcels

Notes

A PN 13 4- 232- 0 35

0.1 0 0.04 0.08 Miles

This map is a user generated static output from an Internet mapping site and is for reference only. Data layers that appear on this map may or may not be

accurate, current, or otherwise reliable.

THIS MAP IS NOT TO BE USED FOR NAVIGATION

Karcher

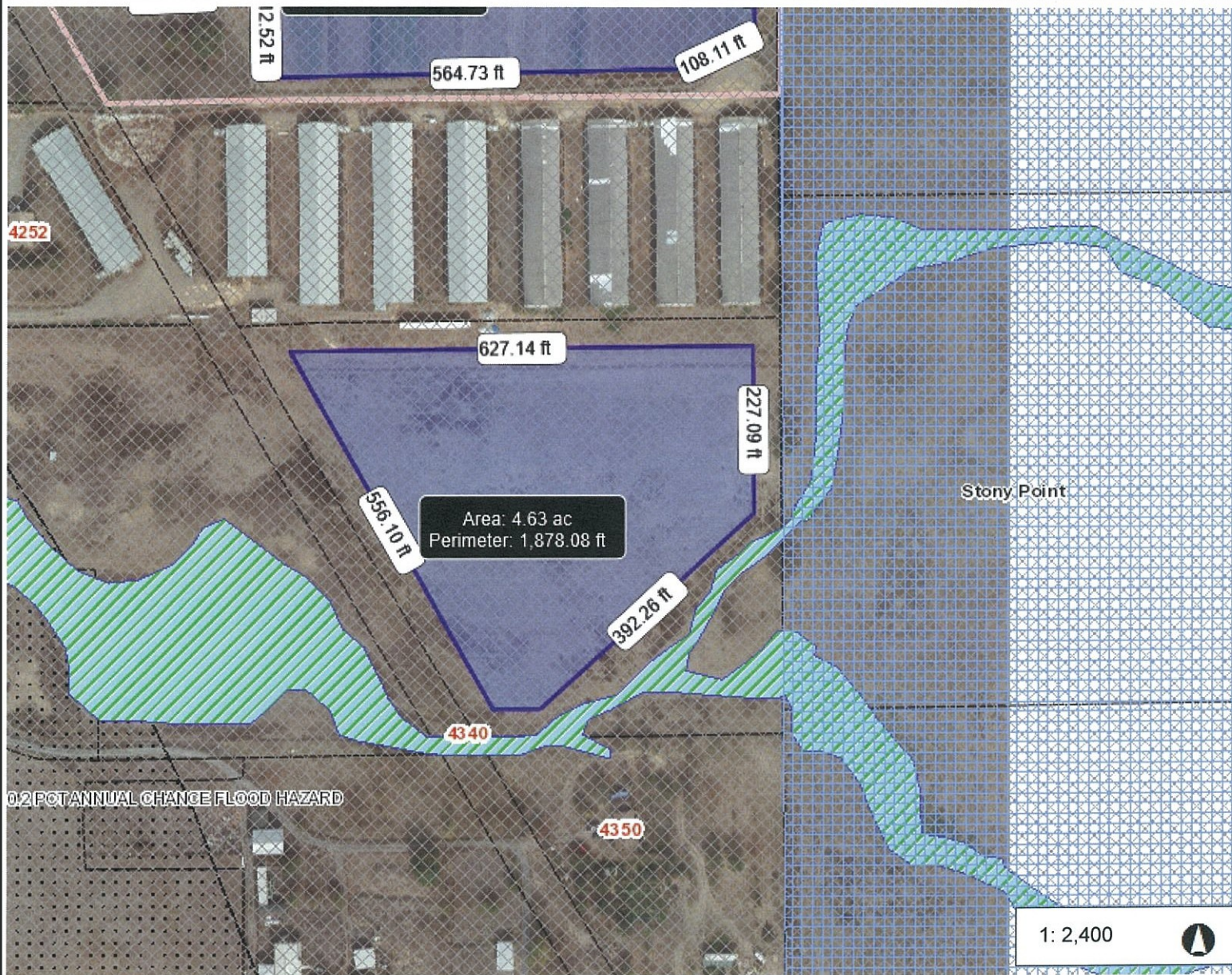

Legend

- 0** NPDES Boundary
- Proposed Conservation Areas**
 - Alton Lane
 - Kelly Farm
 - Llano Crescent
 - Nort hwest Cotati
 - Southeast Cotati
 - Southwest Cotati
 - Southwest Santa Rosa
 - Stony Point
 - Wright
- Breeding Sites**
- Wetlands**
- Critical Habitat**
- Flood Insurance Rate Maps**
 - Flood Zones
 - 100 Year Flood
 - 500 Year Flood
- Creeks**
 - Natural
 - Modified
 - Modified-Natural
- City Boundary**
- Park**
 - Park
 - Community Space
 - Historic
 - Open Space
 - Trail
- Rail Road**
- Parcels**

Notes

APN 134-232-025
East of Walker Ave. north of Schuler

0.1 0 0.04 0.08 Miles

This map is a user generated static output from an Internet mapping site and is for reference only. Data layers that appear on this map may or may not be accurate, current, or otherwise reliable.

THIS MAP IS NOT TO BE USED FOR NAVIGATION

4030 Walker

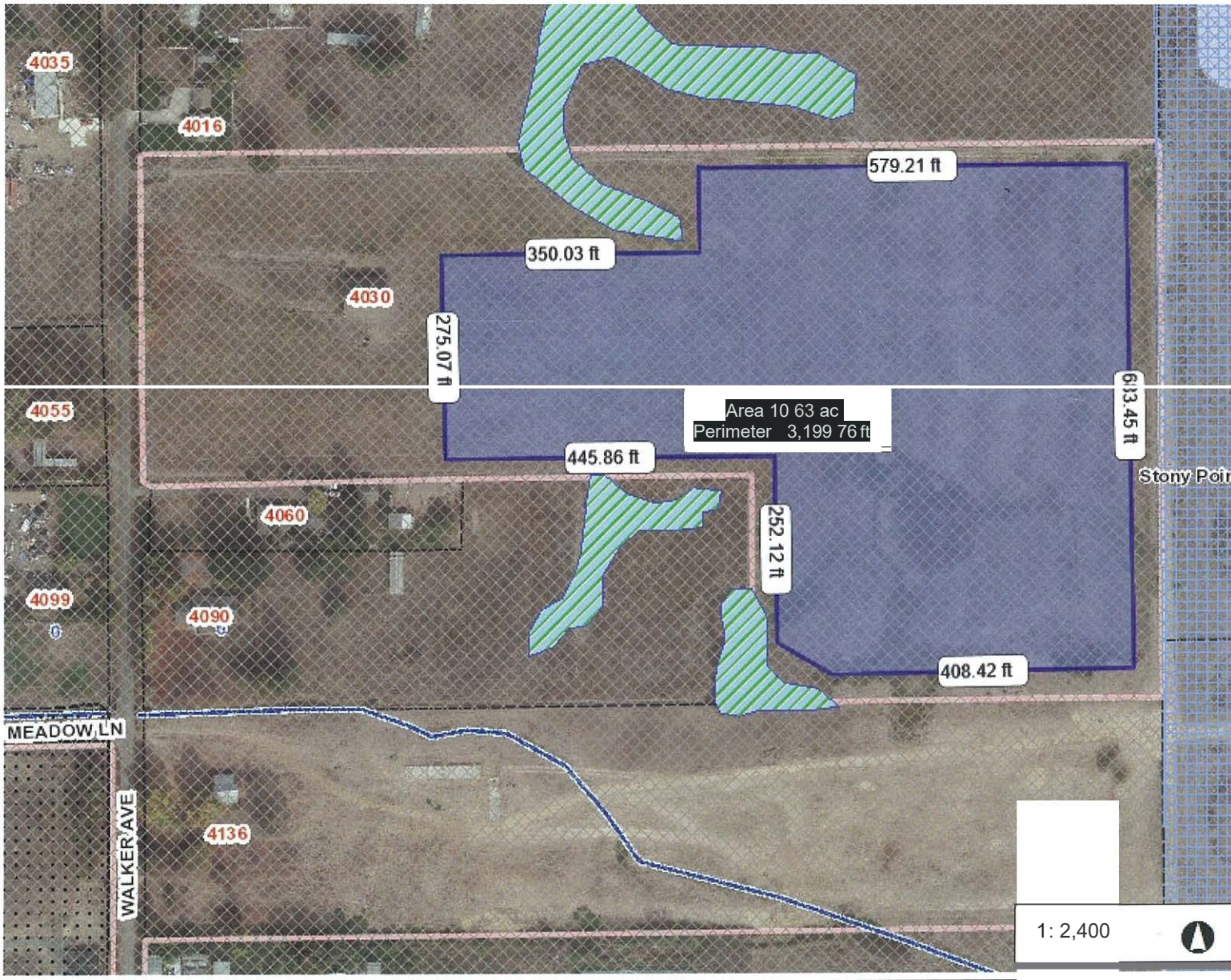

Legend

- D** NPDES Boundary
- Proposed Conservation Areas**
 - tffl* Alton Lane
 - Kelly Fann
 - Llano Crescent
 - Northwest Cotati
 - Southeast Cotati
 - Southwest Cotati
 - Southwest Santa Rosa
- IEEi** Stony Point
- Wright
- Breeding Sites
- !Z** Wet lands
- Q** Critical Habitat
- D** Flood Insurance Rate Maps
- Flood Zones**
 - O** 100 Year Flood
 - O** 500 Year Flood
- Creeks**
 - Natural
 - Modified
 - Modified-Natural
- City Boundary**
- Park**
 - []** Park
 - Community Space
 - !** Historic
 - ;** Open Space
 - Trail
-** Rail Road
- 0** Parcels

Notes

APN 134-232-012

0.1 0 0.04 0.08 Miles

This map is a user generated static output from an Internet mapping site and is for reference only. Data layers that appear on this map may or may not be accurate, current, or otherwise reliable.

THIS MAP IS NOT TO BE USED FOR NAVIGATION

1: 2,400



Pond B

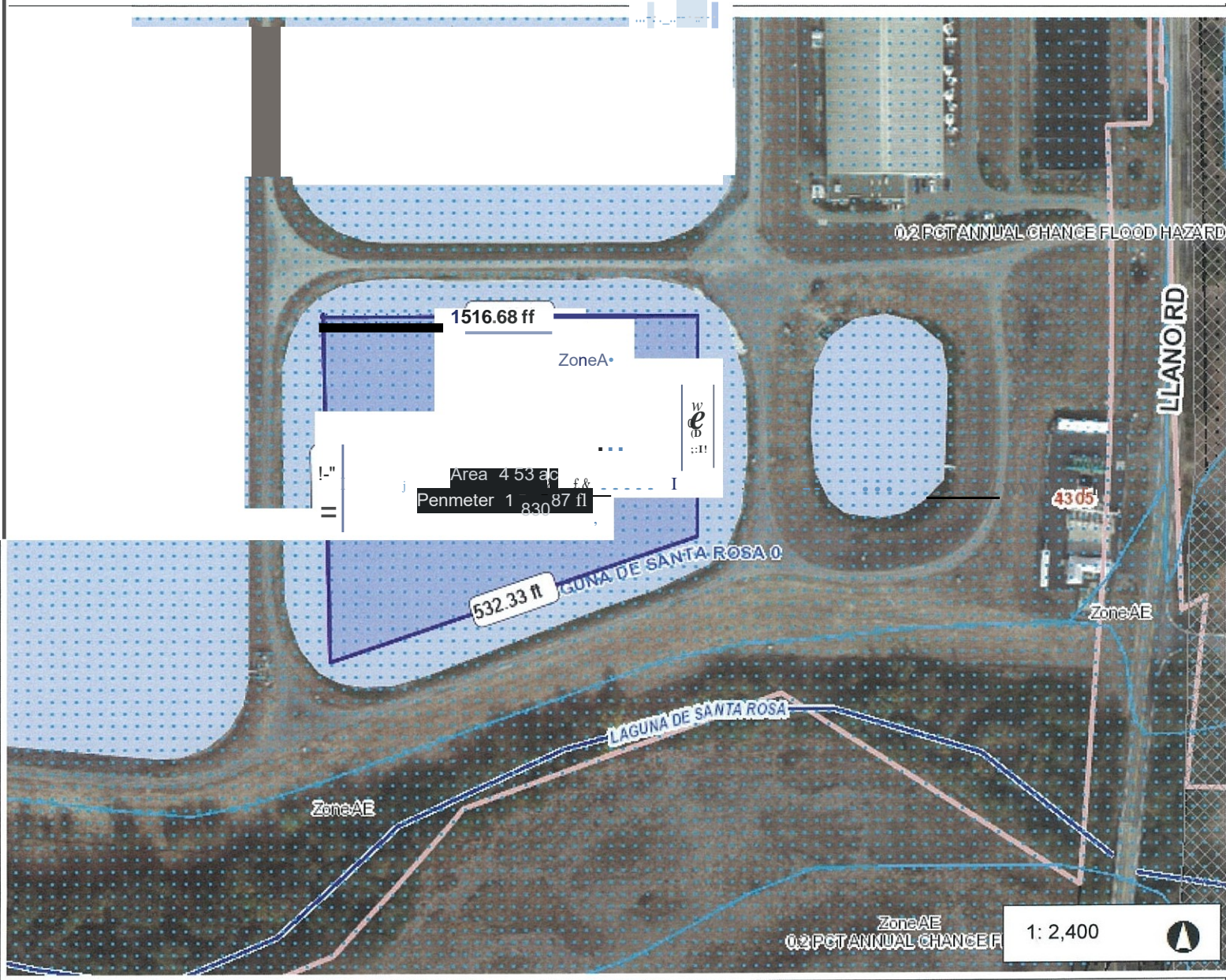

Legend

- D** NPDES Boundary
- Proposed Conservation Areas**
 - lffi** Alton Lane
 - Kelly Farm
 - Llano Crescent
 - Northwest Cotati
 - Southeast Cotati
 - Southwest Cotati
 - Southwest Santa Rosa
 - lffi** Stony Point
 - Im** Wright
- Breeding Sites
- tzj** Wetlands
- IZJ** Critical Habitat
- 0** Flood Insurance Rate Maps
- Flood Zones**
 - 0** 100 Year Flood
 - 0** 500 Year Flood
- Creeks**
 - Natural
 - Modified
 - Modified-Natural
- C** City Boundary
 - Park**
 - a** Park
 - Community Space
 - Historic
 - Open Space
 - Trail
 - + -** Rail Road
 - 0** Parcels

Notes

APN 063-180-025



This map is a user generated static output from an Internet mapping site and is for reference only. Data layers that appear on this map may or may not be accurate, current, or otherwise reliable.
 THISMAPISNOTTOBEUSEDFORNAVIGATION

Delta Pond

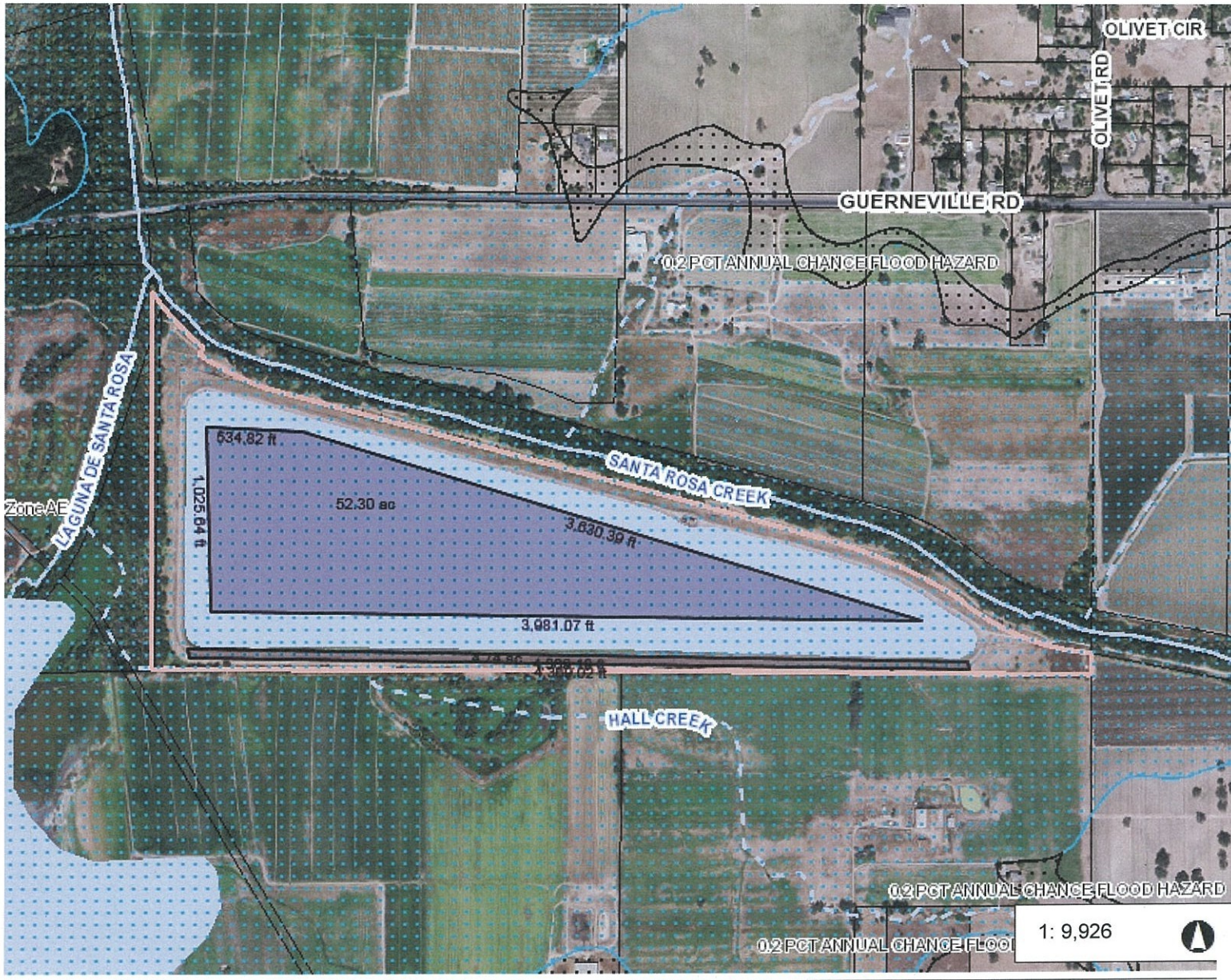

Legend

- NPDES Boundary
- Flood Insurance Rate Maps
- Flood Zones
 - 100YearFlood
 - 500 YearFlood
- Urban Growth Boundary
- City Boundary
- Creek
 - Unknown
 - Surface
 - Subsurface
- Park
 - Park
 - ⋮ Historic
 - ⋮ Open Space
 - ⋮ Trail
- + Rail Road
- Parcels

Notes

727 W Ilwoside Rd
 130-040-008
 52 ac pond, berm- 4.7 ac

0.3 0 0.16 0.31Miles

This map is a user generated static output from an Internet mapping site and is for reference only. Data layers that appear on this map may or may not be accurate, current, or otherwise reliable.

THISMAPISNOTTOBEUSEDFORNAVIGATION

SANTA ROSA WTP
1 MW FLOATING PV PLANT



Ciel & Terre

100 ft

June 5, 2017

Technical Memorandum #10

To: Mike Prinz and Tasha Wright, City of Santa Rosa
From: Luke Werner, Mechanical Digester Mixing Investigation Lead
Alan Zelenka, Kennedy/Jenks Project Manager
Subject: Task 2.5 - Mechanical Digester Mixing Investigation

The purpose of this technical memorandum is fourfold: to review the digester mixing design recommendations previously developed by Kennedy/Jenks in 2005 (see: Technical Memorandum "Laguna Subregional Water Reclamation Facility, Digester Mixing System" (Kennedy/Jenks, March 14, 2003), identify changes that could optimize the original design, compare with other current mixing technologies, and generate an estimate of potential energy savings associated with the preferred approach. While an upgrade to the mixing system may or may not be a direct energy savings measure, there could be potential operational and cost savings benefits such as improved mixing, the potential from increased gas production, and the ability to put fats, oils and grease, and food waste into the digesters.

10.1 Recommendation Summary

The project recommendation is to replace the existing gas mixing system in Digesters 3 and 4 with an externally pumped mixing system due to the following benefits:

- Increased volatile solids reduction, which results in additional valuable digester gas production and reduced biosolids.
- Reduction in biosolids disposal costs.
- Reduction in formation of an upper grease mat and lower solids deposition, thereby maximizing the active volume of the digester.
- Ability to offset natural gas purchases for the existing cogeneration system, thereby lowering operating costs.

The revised project would vary slightly from the original 2005 design, resulting in roughly \$440,000 in capital savings. The resulting project is estimated at about \$2.9 million, which includes the cost of the improvements along with engineering. While horsepower requirements would increase over existing conditions, overall energy use and cost for the Laguna Treatment Plant (LTP) would decrease due to a reduction in natural gas use.

The analysis shows that including the capital cost of \$2.9 million and the resulting savings, the project would create an average annual net savings of nearly \$90,000, with a cumulative net savings of over \$1.2 million over a 20-year period, with a Net Present Value (NPV) of cumulative savings of almost \$1.8 million. These savings are primarily from the reduction in

Memorandum

Santa Rosa EOP – Task 2.5 Mechanical Digester Mixing Investigation

Page 2

biosolids disposal costs, and to a lesser degree the reduction in natural gas use. The Return On Investment (ROI) is 7.6%.

Table 10-1: Summary of Recommended Mixing Improvement Savings

Capital Cost (\$)	Incentive Amount (\$)	Avg Annual Net Savings (\$/Yr)	Cumulative Net Savings (\$)	NPV of Cumulative Net Savings (\$)	ROI (%)
\$2,894,400	\$0	\$89,800	\$1,795,800	\$1,211,200	7.6%

10.2 Background and Current Conditions

The City of Santa Rosa operates LTP, which serves approximately 230,000 residents in Santa Rosa, Rohnert Park, Cotati, Sebastopol, and unincorporated portions of Sonoma County. This tertiary treatment plant has an average annual flow of approximately 17 MGD (2016). Anaerobically digested sludge from the plant is disposed of in a three-part program that sends a portion to a compost facility, a portion to agricultural land, and the balance to a landfill. The compost facility produces a Class A product, suitable for general distribution. The agricultural use and the landfill disposal require Class B sludge, in compliance with the USEPA 503 Regulations.

The four anaerobic digesters are heated with hot water derived from a cogeneration facility that burns digester gas and produces electricity. There are also back-up boilers to supplement the digester heating system (typically unused). The digesters are mixed with gas mixing systems. The two older digesters (Digesters 1 and 2, constructed in 1975) are each mixed with a central gas mixing system that uses a draft tube and lances to emit compressed digester gas near the bottom of the draft tube. The two newer digesters (Digesters 3 and 4, constructed in 1995) each have a series of “cannon” gas mixing systems distributed around the digester interior. The cannon mixing systems have historically not functioned well; they plug frequently, which requires that the digesters be emptied so the cannons can be cleaned. The frequent plugging greatly reduces mixing effectiveness and the cleaning operation is expensive.

The existing mixing mechanism associated with Digesters 3 and 4 is illustrated in Figure 10-1. The gas cannon releases digester gas at the bottom of the draft tube. While gas-style draft tube mixers can produce high flows, the flow is only observed in proximity of the upper portion of the inlet and outlet of the draft tube. Sludge located near the sides and base of the digester receives less mixing energy. Any scum that is located near the top of the liquid will be agitated but may not be mixed with the sludge.

Memorandum

Santa Rosa EOP – Task 2.5 Mechanical Digester Mixing Investigation

Page 3

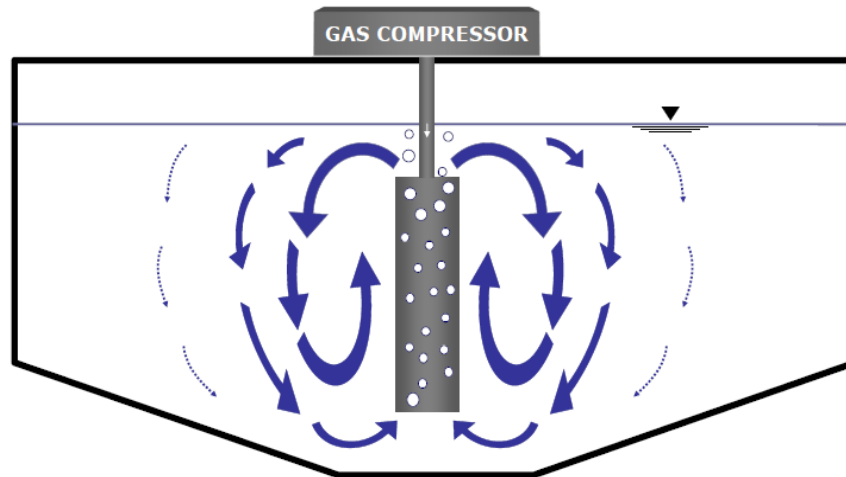

Figure 10-1: Gas-Style Draft Tube Mixing Mechanism

Gas-style draft tube mixers provide good velocities in the immediate vicinity of the tube, but those velocities dissipate rapidly in proportion to the square of horizontal distance from the energy source. As an example, if the velocity is adequate four feet from the tube, the velocity will be only 25% of what is required at a distance of eight feet from the tube. The arrows in Figure 10-1 represent the velocities developed in a digester tank for a gas-style draft tube mixing system. Digesters 3 and 4 are each configured with 40 HP gas compressors.

KJ was tasked with comparing alternative mixing systems and designing a replacement mixing system for Digesters 3 and 4 in 2005, with the recommendation being externally pumped mixing. The existing digester mixing systems for Digesters 1 and 2 were found to be working satisfactorily at the time and were not scheduled to be replaced. The project was bid but never constructed.

10.3 Digester Mixing Energy Requirements

Two of the key parameters for a digester mixing system are sufficient mixing energy and efficient energy transfer to the liquid. **Mixing energy** is typically measured as the energy produced at the pump discharge nozzle in terms of a velocity head. This measurement can be translated into a more common mixing criterion called mixing energy per million gallons of digester capacity (HP/MG). Effective mixing systems typically have a value of 3.3 to 4.2 HP/MG mixing energy. These same digesters experience a turnover of liquid content on the order of 8 to 12 times per day. **Turnover** is a measurement of effective distribution, another key parameter for effective digester mixing. Mixing systems that meet both of these criteria typically experience minimal foaming issues and high rates of volatile solids destruction. Heat distribution is also enhanced with an effective mixing system.

Memorandum

Santa Rosa EOP – Task 2.5 Mechanical Digester Mixing Investigation

Page 4

The three key elements for an effective mixing system include: 1) sufficient energy input, 2) uniform energy distribution, and 3) reliable operation. Digesters 3 and 4 do not meet the recommended mixing energy and daily turnovers since the only mixing is through the 40 HP gas compressors, which do not necessarily turnover the contents, but rather displace the sludge as the gas bubbles move upwards. There are a number of other, more effective mixing technologies available in the industry, including: internal and external propeller-style draft tubes, disk mixers, and externally pumped mixing.

Internal and external propeller-style draft tubes are installed primarily on taller “silo-style” digesters with deep waffle-bottoms or cone-bottoms, where movement of sludge from top to bottom or vice-versa is more effective than rotational mixing. Much like gas-style draft tubes, the mixing is localized, with energy dissipating quickly as it moves away from the tube inlet and outlet. LTP digesters would require a minimum of three cover or wall-mounted draft tubes, with connected motors in the range of 15-20 HP each. Draft tube mixing was eliminated from further evaluation due to the following concerns:

- Pump shaft and impellers are contained within the draft tubes and are not accessible for inspection/maintenance without the use of a crane.
- Mixer impellers and shafts can be susceptible to struvite buildup.
- With the ability to quickly switch flow direction and high liquid velocities in the immediate vicinity of the draft tubes, mechanical draft tube mixing systems have been associated with an increased potential for rapid rise events and foaming.

The disk mixer (known by the trade name Linear Motion Mixer) is the newest of the three technologies and has gained considerable interest throughout the Country due to its low energy requirements and fairly-straightforward installation; however, disk mixing has not been found to consistently meet all three of the key elements of effective mixing. Disk mixer manufacturers report that these mixing systems provide homogeneous mixing by creating a turbulent core of micro and macro eddy currents. These currents are accelerated rapidly through the central opening of an oscillating ring shaped disk. This disk moves up and down through the mixed liquid and creates a linear motion displacement-mixing action. The arrows in Figure 10-2 represent the velocities developed in a digester tank for a disk mixing system. Without a proven track record of successful implementation in digesters under maximum hydraulic and volatile solids loading, it cannot be determined if disk mixers will provide sufficient mixing to maintain long term operational reliability, particularly with high-strength feedstocks.

The mixing system that consistently satisfies the three key elements of effective mixing is an externally pumped system.

Memorandum

Santa Rosa EOP – Task 2.5 Mechanical Digester Mixing Investigation

Page 5

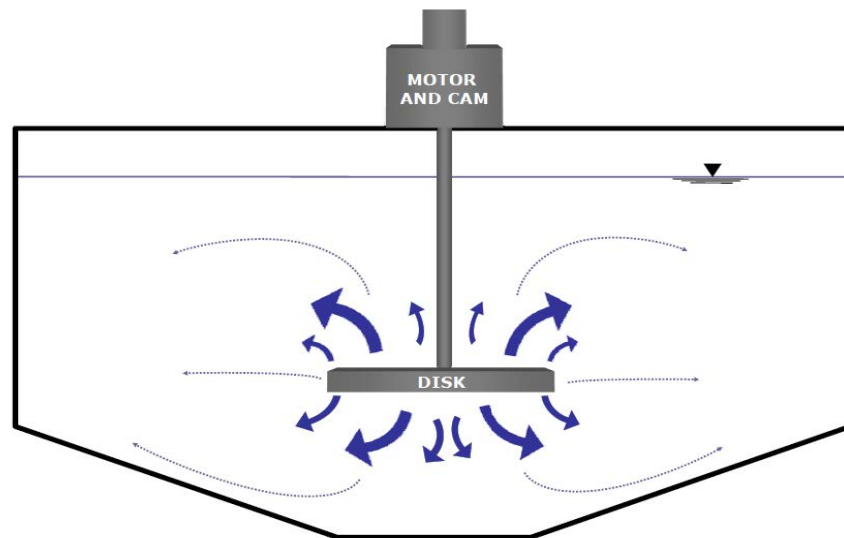

Figure 10-2: Disk Mixing Mechanism

10.4 Considerations for Mixing High-Strength Feedstocks

High-strength feedstocks, like fats, oils, and grease (FOG), and food waste can cause significant problems within the waste stream. Once FOG, or other high-strength wastes are received at the treatment facility, they must be treated and stabilized so that other treatment processes are not compromised, and that the end waste products will be acceptable for regulated disposal.

FOG has been shown to be degradable through anaerobic digestion. Full-scale grease digestion programs have been in existence for nearly 25 years. It takes at least ten steps to break down a complex fatty acid like peanut oil into acetic acid and finally carbon dioxide and methane. Each step requires a specialized bacterial culture. The cultures can be formed by gradually adding grease to an anaerobic digester over a period of weeks (some cultures may already exist based on scum that the digesters are fed from the primary and secondary clarifiers). Once they have become established, the cultures will respond relatively quickly (i.e., within an hour) to the addition of grease to a digester. This reaction is exhibited by a significant increase in the rate of gas production. Substantial turbulence on the surface of the digester contents is required to keep the FOG mixed in with digester biomass. If FOG or other high-strength waste is added to an inadequately mixed digester, it will accumulate on the surface and not degrade. After several years of service, some poorly mixed digesters have accumulated several feet of undigested grease floating on the surface.

Memorandum

Santa Rosa EOP – Task 2.5 Mechanical Digester Mixing Investigation

Page 6

It has been demonstrated that a mixing nozzle located just below the liquid surface inside a digester and pointed slightly upward, in combination with a surface pump suction will create sufficient turbulence and skimming action to keep the FOG mixed in with the biomass. After ten years of service, despite receiving one million gallons of FOG from haulers per year, the digester at one facility in California with this type of mixing system has essentially no accumulation of grease. **At this time, KJ is not aware of a digestion facility in the United States that is accepting FOG, food waste, or other high-strength waste and mixing their digesters with a gas mixing system.**

There is the high potential for heavy debris and/or grit from these outside wastes to settle in the existing digesters, or for a mat of scum to form, potentially reducing the active volume of the digester and contributing to foaming. While the high-strength waste tanks will intercept some debris, it should be assumed that a portion of grit and other debris will enter the digesters. For the remainder of this evaluation, externally pumped mixing will be carried forward as the recommended digester mixing technology.

10.5 Review of 2005 Digester Mixing System Design

The 2005 KJ design included provisions for two dedicated non-clog screw centrifugal pumps and a standby pump to be installed to circulate the sludge. A common header was included so that the standby pump could be used for either digester. Discharge to each of the digesters would be through one of two nozzles located near the top and bottom of the digester. Alternative draw off and discharge pipes were provided so that the mixing patterns within the digesters could be rotated periodically.

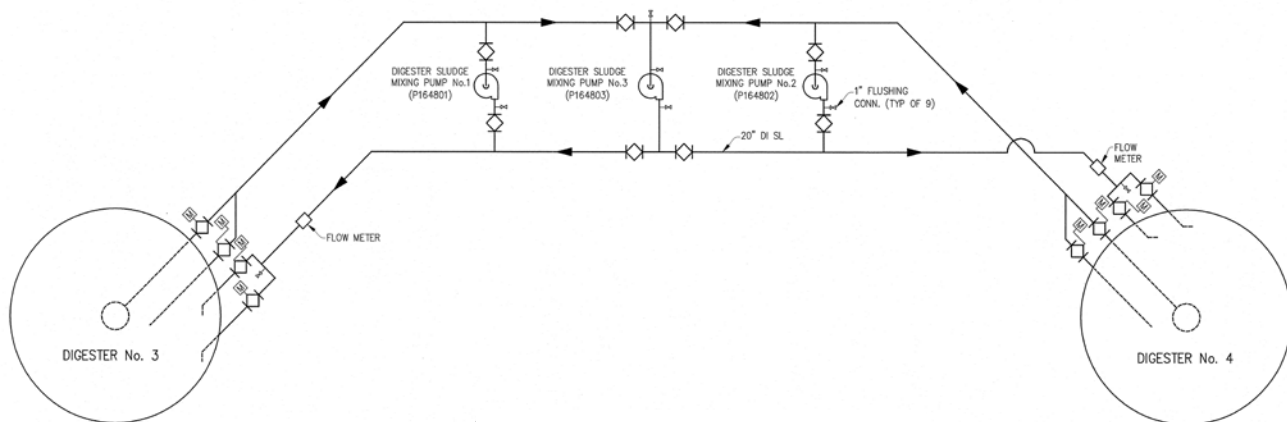

Figure 10-3: Externally Pumped Mixing System Schematic

While the system as-designed will provide effective mixing of wastewater sludges and high-strength feedstocks, recent advancements in pump efficiency may present the possibility for added energy savings. Based on the hydraulic requirements of the system proposed in 2005, each mixing pump was to be rated for 6,400 gallons per minute (gpm) at 25 feet of total dynamic head (TDH), resulting in a 75 HP pump. Wemco-Hidrostral and Hayward Gordon-XCS both

Memorandum

Santa Rosa EOP – Task 2.5 Mechanical Digester Mixing Investigation

Page 7

currently offer screw centrifugal pumps that meet these hydraulic parameters, but with a 60 HP pump.

In addition to energy savings, there is the potential to lower construction cost by reducing the amount of redundancy. The as-designed configuration includes three pumps serving two digesters. It is possible to either manifold the piping so that during short periods of pump maintenance a single pump can mix two digesters at half the normal energy, or LTP can store essential parts, such as motor, belts, etc. onsite. Installation of a full back-up unit may not be necessary to reliably operate the digester mixing system.

The low bidder's estimated construction cost for the original design (mixing only – sludge heating system not included) as well as proposed recommendations for a modified design as described above are shown in the following table. For the comparison, costs for the 2005 design have been escalated to 2015 dollars using the Engineering News Record (ENR) cost indices.

Table 10-2: Digester Mixing System Estimated Construction Cost

	2005 Design¹	2015 Modified Design¹
System Description	3 Pumps 75 HP each	2 Pumps 60 HP each
Estimated Construction Cost ²	\$3,120,000	\$2,680,000

¹ Project excludes sludge heating system and other non-mixing improvements. Cost includes piping, valves, and associated structural, electrical and instrumentation for Digesters 3 & 4.

² 2005 costs based on lowest bid received and escalated to 2015 based on ENR cost indices (7,126-Jan 2005, 10,137-August 2015).

There is the potential for reducing the construction cost of the proposed mixing system design by \$440,000 by eliminating the redundant mixing pump and associated valves, piping, and fittings, and reducing the size of the pump needed to maintain adequate turnovers in the digester.

10.6 Energy Savings Analysis

The existing gas compression mixing system requires continuous operation of 40 HP compressors for each of Digesters 3 and 4. Replacement of the existing mixing system with pumped mixing would result in a net increase in power demand, at the rate of 20 HP per digester. If the new mixing system is run continuously, as recommended to maintain adequate turnovers in the digester, the increase in electrical demand will be 260,000 kWh annually, or roughly \$32,000 at 2016 electrical cost of \$0.1230/kWh. A recommendation was made in the 2014 Process Energy Audit to turn off the mixing pumps during the peak electrical demand period of the day, which occurs for roughly 2.5 hours in the afternoon. This practice is highly

Memorandum

Santa Rosa EOP – Task 2.5 Mechanical Digester Mixing Investigation

Page 8

discouraged, as it can lead to rapid rise or foaming events, and would be detrimental to digester performance when heavily loaded with high strength wastes.

Efficient digester mixing is required for exposure of the active biomass to the digester food source. Efficient mixing translates directly to swift exposure and rapid destruction of volatile solids, which reduces the required detention time and effectively increases digester capacity. One of the primary benefits of upgrading to an effective mixing system is additional gas production resulting from enhanced volatile solids reduction (VSR).

LTP reports an average VSR of 64% with their existing gas mixing system based on solids quantities into and out of the digesters. In order to confirm this value, KJ analyzed historical plant data provided by City staff for the period of May 2014 through April 2015. Three different methods were used to calculate VSR: 1) mass balance around digesters, 2) back-calculation from reported gas production data, and 3) the Van Kleeck method (based on VS percentages in and out of digesters). Only average daily values for 2014 to 2015 were analyzed. A summary of the VSR calculations is presented in Table 10-3.

Table 10-3: VSR Calculation Comparison

Methodology	VS Reduced (lbs/day)	VS Reduction (%)	Difference (%)
Mass Balance (Reported)	16,087	64%	-
Gas Production (Reported)	15,523	49%	-30%
Van Kleeck (Calculated)	14,678	58%	-10%

Using the Van Kleeck method, the result is an average VSR of 58%. This value is slightly lower than the number reported by plant staff using the mass balance approach. The mass balance conducted around the digesters (pounds of VS in versus pounds of VS out) resulted in a value of 64%. Back-calculating VS reduction from gas production flow rates using provided digester gas generation rates (cubic feet of gas per pound of VS destroyed), resulted in an average value of 49%, which is 15% lower than the mass balance approach. Based on experience with other similar facilities, there is generally more confidence in gas production data than other measurements because of the precision of the instrumentation involved; however, based on discussions with LTP staff, there is some doubt to the accuracy of the digester gas flowmeters. Due to the large variation between the gas production and mass balance methods, the middle ground calculated value using the Van Kleeck formula was used for this analysis (58%).

Plants that convert from gas to pumped mixing systems typically experience VSR rates in the range of 55% to 70%, or potentially higher if the solids are subject to long detention times. Although difficult to predict, it is possible that the VSR rate for LTP could increase from 58% to 65% with the addition of an externally pumped mixing system. A 7% increase in the VSR would

Memorandum

Santa Rosa EOP – Task 2.5 Mechanical Digester Mixing Investigation

Page 9

result in additional destruction of roughly 3,200 pounds of VS each day. Digester gas production resulting from the additional volatile destruction is approximately 47,500 cubic feet per day. For this evaluation, it is assumed the additional digester gas generated would directly offset the natural gas used as supplemental fuel in the cogeneration facility. Plant staff report that the average natural gas consumption is 19,250 cubic feet per day, or approximately 72,000 therms per year. While the additional digester gas has a Btu content equivalent to 95,000 therms, savings are limited to only the 72,000 therms per year that can be offset. At a current rate of \$0.51/therm for NG, the additional VS reduction would provide an annual energy savings of approximately \$36,800. These values are based solely on historical solids loading data, and do not reflect additional volatile solids from the High Strength Waste Receiving Facility brought online in the summer of 2016. As well, it does not reflect the value of using the surplus digester gas in cogeneration unit #3 should Santa Rosa chose to operated it using natural gas to generate electricity. The value of offsetting natural gas purchase for cogeneration unit #3 would be approximately another \$11,700 per year.

10.7 Biosolids Disposal

In addition to boosting digester gas production, enhanced volatile solids reduction will also result in fewer solids reaching the belt filter press dewatering system, as shown in Table 10-4. A reduction in 3,200 pounds of VS per day to the belt filter press is equivalent to over 10 wet tons per day of solids requiring disposal, assuming a dewatered cake concentration of 15.3%.

Table 10-4: Biosolids Disposal Reduction

Scenario	Digester Feed			VS Reduction		Residual Biosolids	Delta Biosolids Reduction		
	TS (lbs/day)	VS/TS Ratio (%)	VS (lbs/day)	(%)	(lbs/day)	(lbs/day)	(lbs/day)	(dry tons/day)	(wet tons/day) ¹
Existing Mixing	52,500	89.7%	47,100	58%	27,400	25,100	-	-	-
Pumped Mixing	52,500	89.7%	47,100	65%	30,600	21,900	3,200	1.58	10.3

¹ Dewatered cake based on 2014 – 2015 plant average of 15.3% TS.

Since dewatered biosolids are currently distributed among three different disposal options, the cost for disposal can vary. In order to determine potential disposal savings, the three options have been averaged based on distribution ratios provided by staff, and shown in Table 10-5.

Memorandum

Santa Rosa EOP – Task 2.5 Mechanical Digester Mixing Investigation

Page 10

Table 10-5: Average Biosolids Disposal Savings

Disposal Option	Disposal Cost (\$/wet ton)	Percent of Biosolids (%)	Average Cost (\$/wet ton)	Biosolids Reduction (wet tons/day)	Annual Savings (\$/Yr)
On-site Composting	\$152	26%	\$62	10.3	\$233,000
Land Application	\$29	70%			
Landfill	\$50	4%			

Although the disposal rate can range from \$29 to \$152 depending upon the method, the average cost to the City is \$62 per wet ton. The additional reduction in biosolids resulting from enhanced VS reduction could potentially create annual savings of over \$233,000 in the first year, escalating in value at inflation.

According to plant personnel, the new High Strength Waste Facility is sized to accommodate up to 36,000 gallons per day of liquid feedstocks. Assuming this material has a density similar to grease (e.g., 1.1 pounds per gallon), then there is the potential to receive material with an energy value equivalent to approximately 20 wet tons of grease per day. As noted earlier in the evaluation, substantial turbulence on the surface of the digester contents is required to keep FOG mixed in with digester biomass. If FOG or other high-strength waste is added to an inadequately mixed digester, it will accumulate on the surface and not degrade. Recent experience at other co-digestion facilities including the City of Millbrae, CA and City of West Lafayette, IN, has shown that overall biosolids residual is actually reduced by 20% to 30% following co-digestion in a well-mixed digester. It is believed that this phenomenon is a result of a more balanced carbon-to-nitrogen ratio in the digester, which promotes more efficient metabolism by the microbes. The additional gas production from potential high-strength feedstocks, as well as the potential biosolids reduction, is not factored into this analysis because the actual quantity and quality of material are currently unknown. However, should Santa Rosa bring online cogeneration unit #3 to generate more electricity using purchased natural gas from PG&E, this additional gas can offset the purchases and significantly lower the operating cost of cogeneration unit #3.

10.8 Cost/Savings Model Results and Recommendation

The following elements were incorporated into our cost/savings model to determine the cost-effectiveness of replacing the existing mixing system on Digesters 3 and 4:

- Capital cost of approximately \$2,680,000 (plus 8% for engineering or \$214,400) associated with implementing the mixing improvements in Digesters 3 and 4.

Memorandum

Santa Rosa EOP – Task 2.5 Mechanical Digester Mixing Investigation

Page 11

- Increased electricity use from replacing the 40 HP gas mixing compressors with 60 HP non-clog centrifugal pumps used for the externally pumped mixing system. Estimated at 260,000 kWh per year at an additional cost of about \$32,000 in the first year.
- Additional digester gas production resulting from the enhanced volatile solids reduction from improved mixing, which would offset roughly 72,000 therms per year of natural gas purchases.
- Reduction in biosolids hauling and disposal costs from enhanced volatile solids reduction, estimated in the first year at \$233,000 and increasing at the rate of inflation.

The overall impact on energy and greenhouse gas (GHG) emissions resulting from replacement of the existing digester mixing system is summarized in Table 10-6. The GHG emissions would have increased because of the additional electricity use, but because of the offsetting natural gas purchases overall project GHG emissions decrease by about 336 metric tons of CO₂ per year, and over 6,700 MTCO₂ over the life of the project.

There are currently no utility, state, or federal incentives that apply to these improvements.

The pumps and motors would have a life expectancy of approximately 20 years, with the associated piping, valves, and electrical components expected to last more than 30 years.

Table 10-6: Summary of Project Energy and GHG Savings

Electricity Savings (kWh/Yr)	Electricity Savings (\$/1 st Yr)	GHG Emission Reduction (MT/Yr)	Capital Cost (\$)	Incentive Amount (\$)	Avg Annual Net Savings (\$/Yr)	Cumulative Net Savings (\$)	NPV of Cumulative Net Savings (\$)	ROI (%)
(261,400)	(\$32,200)	336	\$2,894,400	\$0	\$89,800	\$1,795,800	\$1,211,200	7.6%

The analysis indicates that the project, including the capital cost of \$2.9 million, creates a net savings to Santa Rosa and is therefore recommended.

The project would create an average annual net savings of nearly \$90,000, with a cumulative net savings of nearly \$1.8 million over a 20-year period. The NPV of cumulative savings is over \$1.2 million. These savings are primarily from the reduction in biosolids disposal costs, and to a lesser degree the reduction in natural gas use. The Return On Investment (ROI) is 7.6%.

Since the majority of savings are based on a reduction in biosolids disposal costs, which is a result of enhanced volatile solids reduction, the City requested that a sensitivity analysis be conducted in order to determine the project's financial viability associated with 1% increments in VSR, starting with a VSR rate of 56% and increasing to an anticipated VSR rate of 67%, a 12%

Memorandum

Santa Rosa EOP – Task 2.5 Mechanical Digester Mixing Investigation

Page 12

range that encompasses the anticipated VSR of a new externally pumped mixing system. The results of this analysis have been included in Table 10-7.

Table 10-7: Sensitive Analysis of VSR Impact on Project Savings

VSR Rate (%)	Avg Annual Net Savings (\$/Yr)	NPV of Cumulative Net Savings (\$)	ROI (%)
56%	(\$309,093)	(\$4,523,534)	negative
57%	(\$264,773)	(\$3,886,345)	negative
58%	(\$220,453)	(\$3,249,157)	negative
59%	(\$176,132)	(\$2,611,969)	-9.6%
60%	(\$131,812)	(\$1,974,780)	-4.5%
61%	(\$87,492)	(\$1,337,592)	-1.1%
62%	(\$43,172)	(\$700,403)	1.6%
63%	\$1,148	(\$63,215)	3.8%
64%	\$45,468	\$573,973	5.8%
65%	\$89,788	\$1,211,162	7.6%
66%	\$134,109	\$1,848,350	9.4%
67%	\$178,429	\$2,485,538	11.0%

The analysis shows that there is a positive ROI at a volatile solids reduction rate of 62% and above, and the NPV of cumulative net savings starts to become positive at a VSR rate of 64% and above (or a 6% increase from current VSR rate). If an increase in VSR of at least this degree is anticipated for the new mixing system, then the project is anticipated to be cost-effective over the life of the equipment.